

Project Annual Report

December 1, 2011

Silicon Prairie Initiative for Robotics in Information Technology

SPIRIT 2.0

Funded by the National Science Foundation as Project #0733228
Within the Discovery Research K12 Program (DRK12)

Completed by:

Neal Grandgenett, Ph.D. (Education, Co-Principal Investigator)
University of Nebraska at Omaha
107 Kayser Hall, Omaha, NE 68182
(402) 554-2690; ngrandgenett@mail.unomaha.edu

Bing Chen, Ph.D. (Engineering, Principal Investigator)
Peter Kiewit Institute 200A
1110 South 67th Street
Omaha, NE 68182-0572
(402) 554-2769; bchen@mail.unomaha.edu

Elliott Ostler, Ed.D. (Education, Co-Principal Investigator)
University of Nebraska at Omaha
107 Kayser Hall, Omaha, NE 68182
(402) 554-3486; elliottostler@mail.unomaha.edu

Carol Engelmann, (Education, External Evaluator)
Michigan Technological University
1400 Townsend Drive
Houghton, MI 49931-1295
(906) 487-2826; caengelm@mtu.edu

Table of Contents – SPIRIT 2.0 Project Annual Report

| | |
|---|-----------------|
| Executive Summary and Internet Sites | Page 3 |
| Annual Report Narrative | Page 8 |
| Annual Report Purpose | Page 8 |
| Project Focus | Page 10 |
| Intellectual Merit / Broader Impacts..... | Page 11 |
| The Initial TekBot Platform | Page 11 |
| The New CEENBoT Platform | Page 12 |
| Participants (People / Organizations / Collaborators) | Page 13 |
| Project Activities | Page 15 |
| Technical Research in SPIRIT | Page 15 |
| Modular Lesson Development and Cyberinfrastructure | Page 16 |
| SPIRIT Lesson Format | Page 17 |
| The Use of Standardized Test Questions | Page 18 |
| Professional Development with Teachers | Page 18 |
| Data Collection with SPIRIT Students and Comparison Groups | Page 19 |
| Further Data Collection with SPIRIT-DRK12 Students | Page 20 |
| Further SPIRIT Pilot Testing and Field Testing Procedures Plans | Page 21 |
| Online Course Development | Page 23 |
| Virtual CEENBoT Collaboration | Page 23 |
| Project Major Findings | Page 25 |
| Robotics Platform Results to Date | Page 25 |
| Graphical and Other Programming Interface Results to Date | Page 30 |
| Manufacturing Plans and Marketing Results to Date..... | Page 42 |
| Market Research Identified Key Competitors to the CEENBoT | Page 45 |
| SPIRIT Lesson Results to Date | Page 46 |
| Cyberinfrastructure Results to Date | Page 47 |
| Construction Tutorial Development Results | Page 59 |
| Graduate Course Results to Date | Page 60 |
| Teacher Training Results to Date | Page 61 |
| Student Criterion Referenced Test (CRT) results | Page 65 |
| Limitations of District Criterion Referenced Tests | Page 66 |
| Status of Initial Pilot Testing, Field Testing and Test site Agreements | Page 68 |
| Pilot Tests Results to Date | Page 70 |
| 2010 Field Test Study of the SPIRIT Lessons in Middle School Robotics Camp | Page 74 |
| 2011 Field Test Study of the SPIRIT Lessons in Middle School Robotics Camp | Page 78 |
| Virtual CEENBoT Collaboration with 4H Robotics | Page 84 |
| Field Test Study of the CEENBoT in Undergraduate Coursework | Page 88 |
| Artwork added to the Curriculum | Page 89 |
| SPIRIT 2009, 2010 and 2011 Showcase Events | Page 90 |
| Student Participation in Robotics Construction | Page 92 |
| Opportunities for training and development | Page 93 |
| Outreach activities undertaken | Page 94 |
| Publications and Products | Page 96 |
| Journal manuscripts and other publications | Page 96 |
| Products of the SPIRIT grant | Page 99 |
| Internet Site(s) | Page 100 |
| Contributions | Page 100 |
| Contributions within the principal discipline(s) of the project | Page 100 |
| Contributions to other disciplines of science and engineering | Page 103 |
| Contributions to the development of human resources | Page 105 |
| Contributions to the physical, institutional, or information resources | Page 106 |
| Contributions to other aspects of public welfare beyond science | Page 107 |
| Objectives and Scope | Page 108 |
| Project Examples and Illustrations (<i>Appendix Contents Begin that Section</i>) | Page 108 |

December 2011 Executive Summary The SPIRIT 2.0 Project – Progress, Challenges, and Next Steps

Introduction:

The following is an executive summary of the December 2011 annual report for the activities and results of the SPIRIT 2.0 Project, as funded by the NSF-DRK12 program (NSF #0733228). The SPIRIT 2.0 project follows a teacher professional development effort that sought to help middle school mathematics and science teachers learn how to teach science, technology, engineering and mathematics (STEM) concepts using educational robotics, and was first funded by the NSF ITEST Program (NSF #0525111).



This second SPIRIT 2.0 project is now using these trained, creative, and enthusiastic teachers in the development of a cyberinfrastructure-based curriculum to assist in the teaching of STEM concepts using educational robotics. This second SPIRIT effort is completing its fourth of five years of funding. The SPIRIT 2.0 project has also resulted in a new educational robotics platform, called the CEENBoT, which has received NSF Phase I production support for a University of Nebraska startup company (NSF SBIR# 0945280) and is now being routinely produced for school orders, with newly enhanced versions distributed frequently during the last year. This executive summary discusses the SPIRIT 2.0 project as funded by DRK12, and how it is systematically undertaking its curriculum and robotic platform development efforts.

A Summary of the SPIRIT Activities and Results:

- The SPIRIT 2.0 project has led to a new flexible, inexpensive, educational robotics platform, called the CEENBoT (Computer and Electronics Engineering Robot), which is now being produced by a University of Nebraska startup company (CEENBoT Inc.). This non-profit company was awarded a NSF SBIR grant, for initial refinements in the CEENBoT production, and is now producing CEENBoTs and filling orders from various schools and other educational organizations around the country.



- The project has now supported intense professional development activities for 305 mathematics and science teachers (primarily middle school) in educational robotics, in extended multi-day workshops, that also led to some creative ideas for lessons.
- The SPIRIT 2.0 project has led to the prototype of an online educational robotics curriculum, that as of December 2011 now includes more than 260 lessons, standards-mapped assessments, construction tutorials, robot games, and a wide number of support materials, that have been professionally edited with a team of curriculum and content experts.

- The lesson cyberinfrastructure for the SPIRIT 2.0 Project includes an innovative modular lesson structure, that partitions lessons into five components, including A - asking questions, E – exploring learning, I – instructing learning, O – organizing learning, and U – understanding what has been learned. Lessons can be searched and combined by a teacher, along with classroom assessments, that can be used to create tailor-made sequence of activities.
- The lesson cyberinfrastructure is also including a page of released standardized test questions associated with many of the lessons. These sample standardized test questions are from sources such as the National Assessment of Educational Progress (NAEP), or other organizations that have released their items. These items can be used by teachers to test students on the STEM concept topics covered in the educational robotics lessons.
- The CEENBoT robotics platform now includes the capability to be programmed by use of a TI Graphing Calculator, an Application Programming Interface (API) or an open-source Graphical Programming Interface (GPI).
- Surveys related to the SPIRIT professional development efforts with teachers have documented positive changes in teacher perceptions of their instructional competence in educational robotics, engineering design, electronics, cooperative learning, and problem-based learning.
- Early in the project criterion-referenced test data of students involved with trained SPIRIT teachers, although limited for project interpretation (due to the way these tests are administered by schools) have been encouraging. Of the 29 groupings of students examined (N = 1058), a total of 21 classes scored above their school averages on the related criterion referenced tests, and a total of 23 groups scored above district averages.
- Using more consistent attitude and content assessments, results were encouraging for short duration pilot tests (4 hours) using a controlled time series design, with students participating in a pilot test of individual SPIRIT lessons and activities (N = 141). A dependent t-test showed a significant increase in STEM attitudes ($t(123) = 6.92, p < .0001, d = .62$). A similar t-test for content topics showed a slight increase in scores (pre M = 16.57, post M = 16.81); however, the content-related increases for this short intervention were not significant ($t(131) = .91, p = .36$). In comparison, the control group analyses indicated no significant increases in either category.
- Longer duration pilot tests have included content and attitude efforts with several SPIRIT lessons, including middle school math (N=12), middle school science (N=18), and an engineering topics class (N=7). The math class showed improvement on the content assessment (Pre M=13.25, S=3.98; Post M=15.00, S=3.02; $t(11) = 2.83, p = .016$) as well as



the attitude assessment (Pre $M=127.5$, $S=23.6$; Post $M=140.3$, $S=17.61$; $t(10) = 3.23$, $p = .010$). However, the other two classes did not show significant improvement on either assessment, leading to refinements in both the assessments and the lessons piloted.

- Carefully organized field testing efforts have followed pilot tests done early in the project. During the summer of 2010 and 2011, and the winter break of 2010/2011, fieldtesting efforts of 3 day durations with multiple SPIRIT lessons were undertaken with middle school students in Robotic Camps held at Gross High School in Omaha, Nebraska (total N of 87 students). After a series of SPIRIT lessons, students in each fieldtest showed significant increases on selected content items ($p < .05$), a STEM Interest Inventory ($p < .05$) and on selected questions of a STEM Coursework Interest and Expectations survey ($p < .05$).
- The students attending the 2010 and 2011 CEENBoT Showcases, as part of the Nebraska Robotics Expo, took pretest and posttest surveys on engineering concepts, programming concepts, and engineering design, as well as STEM attitudes and selected workplace skills including teamwork and problem solving. Surveys in both years, showed increases in several engineering concepts ($p < .05$), attitudes about science ($p < .05$), attitudes about problem solving ($p < .05$), and on the overall workplace skills instrument ($p < .01$).
- The undergraduate CEEN department also did a pilot study with their seniors in their undergraduate engineering program ($N=27$) and confirmed that the CEENBoT was a strong contributor to student perceptions of learning in that program. This result was encouraging to the SPIRIT project in that the CEENBoT continued to be useful in higher education coursework, even though its capabilities were being refined especially for middle school and high school instruction, adding encouragement toward the goal of a flexible, K-16 use.
- Working closely with the 4-H organization and a leadership team from the University of Nebraska at Lincoln, the project has contributed to an online virtual CEENBoT program, that is a robotics simulation that will be distributed to 4-H clubs and camps. Field tests of this intervention showed improvements on seven “big ideas” related to STEM concepts in an open ended and rubric scored assessment instrument.
- The SPIRIT project is also posting STEM lessons from the NSF funded Project SHINE (NSF #0903157) into the interactive lesson database. Project SHINE is using the SPIRIT lesson format and has agreed to make the lessons available to SPIRIT teachers. These lessons are focused on business/industry connections to STEM, and include a variety of robotics related topics, such as energy, mechatronics, electronics, industrial robotics.
- Some lessons in the SPIRIT database may be used with more than one robot platform (such as looking at acceleration) but are written primarily for use with the CEENBoT. It is hoped that the wide variety of SPIRIT lessons, and the flexibility of the CEENBoT platform, will encourage a wide group of teachers to visit the website and to consider educational robotics in the teaching of STEM concepts. We are hoping that the quality of the lessons will also encourage them to consider the CEENBoT platform (a learning tool carefully aligned with undergraduate coursework), as their platform of choice for educational robotics activities.

- Working closely in partnership with the NSF Funded GearTech21 Project (PI: Dr. Brad Barker), the SPIRIT leadership team helped to produce and edit the book: "Educational Robotics in K-12 Education". The book is edited by Drs. Bradley Barker, Gwen Nugent, Neal Grandgenett (CoPI: SPIRIT Project), and Viacheslav I. Adamchuk. The book will be published by IGI Global (www.igi-global.com) and is scheduled for release in early Spring 2012. The research-based book contains a chapter on the SPIRIT project, as well as chapters from various projects and authors contributed from around the World.
- With the advance of new technologies, such as iPad, tablet computers, and mobile phones, the SPIRIT project is keeping pace with the integration of new technologies. For example, there is a development underway by the technical team to make the CEENBoT compatible with remote control by the Android mobile phone, and development underway by the educational team to make the lesson cyberinfrastructure available to teachers over an iPad.

Project Challenges (Now being addressed in SPIRIT 2.0):

- As the SPIRIT project scales its support of educational robotics nationally, teacher training is becoming difficult to do cost effectively. In response to this challenge, the SPIRIT Project is beginning to offer workshops for teachers at major conferences, such as the 2012 International Technology and Engineering Educators Conference, in Long Beach California, March 15-17, where teachers will participate in a 3 hour workshop, to introduce them to the CEENBoT platform and SPIRIT Lesson database. This is a more cost effective paradigm for teacher training.
- It was difficult to examine academic success early in the project using existing district criterion referenced tests, within the classrooms of the SPIRIT teachers, particularly when they undertook a relatively mixed set of lessons. This challenge has led to a more structured pilot testing and field-testing efforts, with more focused pretest and posttest assessments.
- The establishment of student comparison groups was difficult in the SPIRIT project, although a pilot comparison group of 141 students was successfully established. Few teachers and parents wanted to be part of a traditional "control group". To address this comparison challenge, classrooms willing to be in a control group (and take the pretest-posttest assessments) were provided with a large educational robotics event, following the posttest. This has helped to recruit control group subjects.
- The use of educational robotics in STEM instruction can be seen as a significant financial investment by school districts, involving a need for new robotics equipment. In response to this challenge, the SPIRIT project is refining an inexpensive, flexible, and open source robotics platform that can use scrounged parts, as well as off the shelf parts, called the CEENBoT. This platform is attempting to steadily lower the costs for school robotics use.
- The SPIRIT project is facing the challenge of producing and repairing CEENBoTs, as well as providing technical support, on a rapidly expanding scale. To assist in robot production and repair, a University of Nebraska startup company (CEENBoT INC.) has been established. The company is still early in its evolution, and it is difficult to keep pace with the demand for CEENBoTs by schools and other organizations.

Internet Site(s):

SPIRIT Education Components of the Website: <http://www.ceen.unomaha.edu/TekBots/SPIRIT2/>

SPIRIT Cyberinfrastructure Prototype: <http://spirit.unomaha.edu/>

SPIRIT Video Clip Sample: <http://www.ceen.unomaha.edu/TekBots/Shared/Video/jumbotron07/>

SPIRIT General Website: <http://www.ceen.unomaha.edu/TekBots/>



CEENBot / TekBot Site

SPIRIT 2.0 Education



Silicon Prairie Initiative for Robotics in Information Technology 2.0 (SPIRIT 2.0)

Annual Report Narrative December 1, 2011

Annual Report Purpose:

This document is the 3rd year annual report for the SPIRIT 2.0 project, as of December 15, 2011. It is submitted as a stand-alone evaluation report attached to the NSF FastLane system. Parts of this report have also been entered into the FastLane system directly, through a copy and paste process. The SPIRIT 2.0 report represents the work of many professionals engaged with the project and provides a summary for the past curriculum development activities and results related to the DRK12 grant funding (NSF #0733228).



*“If you want to go quickly, go alone. If you want to go far then go to together”
African Proverb*

Project Focus:

The SPIRIT 2.0 Project has continued to evolve from an initial SPIRIT 1.0 ITEST project (NSF #0525111), which undertook three years of teacher professional development efforts, to now involve these teachers and other education and engineering experts in an “educational robotics touch point” curriculum development effort, as funded formally by DRK-12 in this grant project (NSF #0733228). Both the SPIRIT efforts are consistent with the standards-based learning discussed by many professional organizations, related to science, technology, engineering and mathematics instruction (ISTE, 1999; ITEA 2000; NCTM, 2000; NAS, 1996), within a relatively new context of educational robotics.

This SPIRIT Project responds directly to a growing national concern that the United States' educational efforts are not producing enough STEM (Science, Technology, Engineering and Mathematics) professionals, especially as compared to many other countries around the world. National reports such as the 2010 *Rising Above the Gathering Storm Revisited*, paint an increasingly alarming picture for U.S. competitiveness in STEM areas as summarized across educational reports and statistics (National Academy of Sciences, 2010). U.S. competitiveness concerns relate to sample statistics such as: 51% of U.S. patents are now awarded to non-US companies (Donohue, 2010) and that the U.S. now ranks 27th among developed nations in the proportion of college students receiving undergraduate degrees in STEM areas (Organization for Economic Cooperation and Development, 2009). The United States government is becoming increasingly concerned by these alarming national statistics to the point that President Obama, in his 2011 State of the Union Address, identified STEM education concerns as our nation's new "Sputnik moment."

Formal educational organizations (such as universities and K12 school districts) must come together with informal educational organizations (such as zoos, museums, 4H and STEM-related businesses) to help make STEM concepts come alive, and to help students to see relevance and excitement in what they learn. Educational Robotics is an opportunity to do just that as undertaken in SPIRIT. Today we live in a changing world for STEM instruction where the components of a truly effective STEM education environment are changing rapidly as computer technology impacts the ways in which we can teach and learn about these important disciplines (Heid, 2005; Hegedus & Kaput, 2004). Robotics technologies are particularly exciting in this context, and offer a promise of helping to better reach students who are part of a new generation of digital natives who prefer technology-based learning (Prensky, 2000)

The SPIRIT teacher professional development efforts, generally preceding the curriculum development efforts, have sought to use teacher professional development as a driver to transform the culture of mathematics and science instruction, as well as to empower student interest and achievement through revitalized, inquiry-based activities using robotics. The SPIRIT teacher professional development efforts are continuing, since we recognize that effective teacher professional development is a key variable for educational reform in mathematics and science (Loucks-Horsley et al., 2003; Richardson, 1994) and middle school grades are often where some of the most important general mathematics and science instruction is undertaken (Adams et al., 2000). SPIRIT's vision for this teacher professional development is to continue to refine our effective teacher professional development model to support the integration of educational robotics into the middle school; to train middle school science and mathematics teachers in engineering design principles by the use of educational robotics; to help teachers plan for the integration of educational robotics into regular science and mathematics instruction; to try out lessons that they have developed for the SPIRIT curriculum; and to try to increase student success by better reaching all of their students, in any demographic category.

As an extension of the initial professional development effort undertaken in the first SPIRIT project, a second project, called SPIRIT 2.0 was conceptualized to build upon the creative synergy of these teachers, and to create a middle school educational robotics curriculum by 2013. The curriculum will comprise a set of instructional modules organized into flexible, Internet-accessible lessons and lesson support materials. This SPIRIT curriculum is targeting the instruction of specific topics or "touch points" in science, technology, engineering, and mathematics (STEM). A total of 305 teachers that have now been trained in SPIRIT

summer institutes, workshops, and graduate courses, are now routinely contributing lesson and classroom ideas to the SPIRIT 2.0 curriculum development efforts. Thus, the focus of the SPIRIT 2.0 curriculum effort consists of: 1) to develop a Grades 5-8 educational robotics curriculum that will enhance the student learning of STEM concepts; 2) to refine curriculum in an extended development process, using peer editing, expert review, pilot testing, and field-testing; 3) to integrate a series of assessments into the curriculum; 4) to extend the newly developed CEENBoT platform with technical enhancements, hardware tutorials, software guidelines, and a Graphical Programming Interface; 5) to create a cyberinfrastructure support environment, including a flexible sequencing of all curriculum materials; and 6) to scale the use of the curriculum, by use of national workshops. We have made significant progress in all of these focus areas.

Review of Intellectual Merit and Broader Impacts:

As of December 2011, and the project has progressed from SPIRIT to SPIRIT 2.0, the project staff have worked hard to maintain both the intellectual merit and the broader impacts of the project, as originally described in both of the projects (ITEST and DRK12). Those important intellectual merit and broader impact considerations are now reviewed.

The **intellectual merit** of the project is represented by both the professional development model undertaken within the initial SPIRIT project (funded by ITEST), and the “touch point” curriculum being developed in the SPIRIT 2.0 project (as funded by DRK12). The ability to now work closely with SPIRIT trained teachers as a source of creative ideas and developing lessons to support an evolving educational robotics curriculum has been critical to our success to date in curriculum development. The



intellectual merit of the project is also represented by the new “open source” CEENBoT robotics platform, that was initially conceptualized in the SPIRIT project, and that is now being refined with teacher input. Further, this teacher input has led to a robust SPIRIT cyberinfrastructure strategy for the flexible delivery of lessons to teachers using the Internet. This further curriculum development effort of the SPIRIT project (as supported by DR12) is creating web-based mechanisms for teachers to select compatible lesson components by grade level, STEM topic and national standards, as well as the use of an electronic “On-Call Technician” that will be able to eventually diagnose CEENBoT malfunctions and eventually guide teachers in repair and maintenance strategies. The overall SPIRIT project has also led to several relationships with school districts that have agreed to pilot test and field test the evolving curriculum resources and that work is progressing nicely to refine the curriculum and to investigate the impact of its use with students.

The **broader impacts of the project** have focused on supporting the use of educational robotics in any school district across the country, toward a more creative learning of mathematics and science at the middle school level. The use of an “open source”, less expensive, more flexible, and more realistic robotics platform (the CEENBoT), than is available in the commercial setting, that is also supported by a free, engaging and online curriculum, allows for a broader participation by schools in educational robotics. Further, by helping SPIRIT teachers (who have participated in extensive educational robotics professional development) to systematically contribute to the evolving educational curriculum, the curriculum activities can more effectively address classroom realities, and build upon the natural creativity and ideas of these experienced teachers. These SPIRIT teachers are also becoming local, regional, and potentially national, “role-models” for the use of educational robotics in STEM instruction, and as of 2011, are also now assisting in leading national workshops, such as a major national workshop at the upcoming 2012 International Technology and Engineering Educator’s Association Conference (ITEEA). This consistently expanding SPIRIT network of teachers is also becoming a significant source of experience, guidance, and encouragement to enhance the curriculum and is now supporting the pilot testing of individual lessons and the field-testing of multiple sets of lessons within typical classroom settings. The ideas of these innovative SPIRIT project teachers have already been directly integrated into the evolving curriculum and its resources, that now includes teacher lessons, support materials, assessments, sample standardized test questions, technical tutorials, teacher professional development guidance, and an interactive cyberinfrastructure support environment. As the project continues to expand and evolve, the SPIRIT project also promises to support a greater general awareness and appreciation of engineering and technology (representing the T&E of STEM), as these two disciplines connect to innovative science and mathematics instruction

The Initial TekBot Platform:

One of the keys to the instructional promise for educational robotics is the potential engagement and motivation of students with the robotics platform itself. Successful middle school curriculum often needs a motivating context (Adams et al., 2000; Greenwald, 2000), and robotics can be a motivating topic for students (Heer et al., 2003). The first SPIRIT ITEST Project was initiated with the TekBot educational robotics platform, which is a flexible, hands-on platform for learning developed by Oregon State University. The TekBot was a useful educational tool to provide a motivational student context for STEM learning. This mobile robotics platform was able to demonstrate a number of STEM concepts within an engineering environment, including microprocessors, mechanics, wireless communications and control, and sensors. It also has the benefit of being able to use limited “scrounged components” that one might find around the local electronics store, hobby outlet, or surplus parts store. However, we quickly evolved in SPIRIT 2.0 to creating our own SPIRIT educational robotics platform called the CEENBoT due to some significant limitations

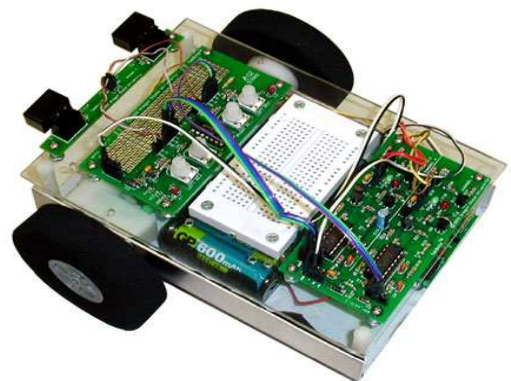

with the TekBot platform, related to its use within a middle school classroom and its often extended and rough handling by middle school students and teachers.

The New CEENBoT Platform:

Our work in the SPIRIT project has led us to develop a new educational platform that was similar to the TekBot, but significantly enhanced and expanded, as well as more readily modified by students, called the CEENBoT. This platform was more compatible with the rough handling by middle school and high school students. The versatility of the platform allows for a greater diversity of learning environments including in-school, afterschool, at-home and university settings.

Relative to the VEX and the LEGO robot, which are advanced consumer toys with simple “drag and drop” programming software and limited exposure to electronics engineering design, the CEENBoT offers a more modifiable platform, in various versions, with non-proprietary off-the-shelf (OTS) electronic hobbyist components for creative learning, involving a diversity of possible activities from hardware implementation, experimentation and software language development, all in an “open source context” that is completely open to user experimentation.



Relative to the TekBot learning platform (developed by Oregon State University), the SPIRIT Project’s CEENBoT also offers a more robust platform for learning that is more durable and rugged for extended activities, is less prone to accidental damage, and comes with a larger prototyping board to help students to design possible enhancements. The CEENBoT also uses more rugged motors and steering components. Both a multi-board and single board version is available, as shown above.

The CEENBoT was developed by engineering faculty and students at the University of Nebraska’s Department of Computer and Electronics Engineering, building upon feedback from SPIRIT Teachers in K-12, and working closely with the faculty of the University of Nebraska at Omaha’s College of Education, which has helped to synthesize suggestions related to the CEENBoT’s current successful migration into the K-12 environments and strong embrace by middle school teachers and students.

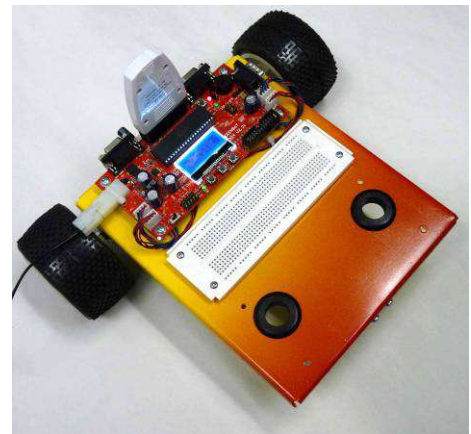
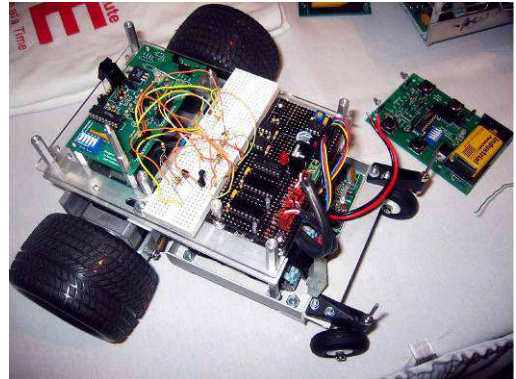

Participants

1. What people have worked on your project?

The following people represent the leadership team for the SPIRIT project:

PI: Dr. Bing Chen, Computer and Electronics Engineering (CEEN), Peter Kiewit Institute
CoPI: Dr. Neal Grandgenett, Teacher Education, University of Nebraska at Omaha
CoPI: Dr. Elliott Ostler, Teacher Education, University of Nebraska at Omaha
Senior: Dr. Bob Goeman, Teacher Education, University of Nebraska at Omaha
Senior: Mr. Dennis Deyen, Engineer and CTO, CEENBoT INC
Senior: Mr. Roger Sash, Computer and Electronics Engineering, Peter Kiewit Institute
Senior: Ms. Alisa Gilmore, Computer and Electronics Engineering, Peter Kiewit Institute
Senior: Mr. Herb Detloff, Computer and Electronics Engineering, Peter Kiewit Institute
Senior: Mr. Steve Eggerling, Computer and Electronics Engineering, Peter Kiewit Institute
Senior: Mr. Bill Schnase, Teacher Education, University of Nebraska at Omaha
Senior: Ms. Brian Sandall, Mathematics Teacher, Westside Community Schools
Senior: Mr. Ken Townsend, Computer and Electronics Engineering, Peter Kiewit Institute
Senior: Mr. Jim Harrington, Mathematics Supervisor, Omaha Public Schools
Senior: Mr. Chris Schaben, Science Supervisor, Omaha Public Schools
Senior: Mr. Steve Hamersky, Physics and Technology Specialist, Omaha Catholic Schools
Senior: Dr. Gwen Nugent, Educational Researcher, University of Nebraska at Lincoln
Senior: Mr. Bill Schnase, Teacher Education, University of Nebraska at Omaha
Senior: Mr. Jim Wolfe, Teacher Education, University of Nebraska at Omaha
Senior: Dr. Paul Clark, Teacher Education, University of Nebraska at Omaha
Senior: Dr. Mike Timms, Measurement and Evaluation, Walnut Creek, California

In addition to the Project Leadership Team, a total of 305 teachers have now been fully trained in the SPIRIT project and many of these teachers have been actively involved in the SPIRIT curriculum development activities. Of the teachers trained to date, a total of 45% are male and 55% are female. The project has been very pleased with its female teacher participation, since one of the long-term interests of the project has been to increase the number of female role models in STEM.

2. What other organizations have been involved as partners?

The Omaha Public Schools (OPS) remains a strong K12 partner in the SPIRIT Project, and has contributed significantly to the teacher professional development planning and curriculum interactions of the SPIRIT effort. OPS enrolls more than 50,000 students in urban neighborhoods and is an ideal partner in the SPIRIT 2.0 DRK12 curriculum development efforts and the related pilot testing and field testing of the educational robotics curriculum. Nearly 80% of the state's African American students, 60% of the state's Hispanic students, and 35% of the state's Native American students are enrolled in OPS. At least 90 languages from across the world are spoken within the homes of the OPS district.

In addition to OPS, the SPIRIT project has established a close working relationship with the Metropolitan Omaha Education Consortium (MOEC), which also includes OPS, for various curriculum pilot testing and field-testing efforts. MOEC is a collaborative organization involving the University of Nebraska at Omaha, the thirteen metropolitan area school districts, and two educational service units. The MOEC consortium involves nearly 100,000 students, and is a catalyst for identifying high priority issues common to member organizations. MOEC has offered to help communicate with area school districts and to help to identify potential pilot

testing and field-testing sites within their consortium, as the SPIRIT 2.0 project becomes ready to test and refine the new curriculum.

Educational Service Unit #3 in Omaha, Nebraska has also become a valuable partner in the SPIRIT project in teacher recruitment and in providing a general awareness of the project within MOEC. ESU#3 has also been a key partner in helping us to establish various control and comparison groups for our curriculum pilot testing and field-testing strategies. Some initial efforts at pilot testing and field-testing have already been undertaken and more are planned as part of the SPIRIT 2.0 curriculum refinement efforts. In one of the key pilot testing efforts to date, which has used a time series design (explained later in the report), ESU#3 asked a designated mix of teachers to have their students take the project's pretests and posttests in a specific period of time (without using the robotics materials). Then after the posttests were completed, the SPIRIT project held a three to four hour robotics event at ESU#3 for all the participating students and teachers in the comparison group, where some specific SPIRIT lessons and activities were piloted. This provided a convenient set of student comparison data, while also providing some instructional benefits for control students, after the comparison group data was received. We also undertook several class sized field tests during 2010 and 2011 (described later in the report), and are also planning an expansion of those efforts during 2012, where the individual SPIRIT lessons will be further pilot tested, and sets of SPIRIT lessons will be field-tested in the systematic curriculum refinement efforts of SPIRIT 2.0.

3. Have you had other collaborators or contacts?

Continuing in 2011, the SPIRIT Project has undertaken a close lesson development partnership with Project SHINE a recently funded NSF Advanced Technological Education (ATE) Project at Central Community College in Nebraska (NSF#0903157). Project SHINE is developing STEM lessons that have a business theme to them, with many of the lessons related to industrial robotics, energy, manufacturing, or mechatronics. These lessons have a strong business connection to them and businesses worked with the teachers to develop the lessons. The SPIRIT team is working closely with Project SHINE to put the lessons developed into a compatible AEIOU lesson format so that the lessons can also be added to the SPIRIT lesson database. In this way, SPIRIT teachers can springboard from their educational robotics activities, into related STEM activities (such as mechatronics, electronics, industrial robotics, energy, etc.). A total of 143 SHINE lessons have now been added to the SPIRIT database, with nearly 150 in the pipeline, for eventual free use by teachers.

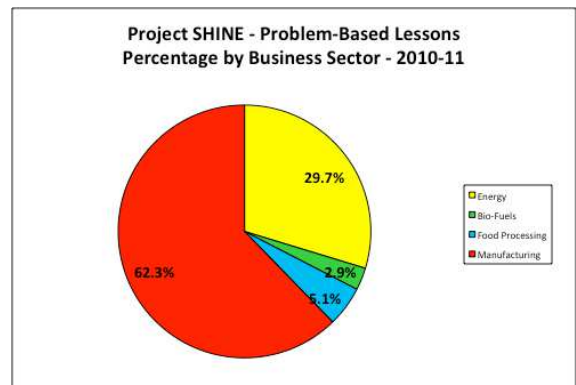

The Peter Kiewit Institute (PKI) has remained a strong collaborator throughout the ITEST professional development funding and continues as a strong partner now into the SPIRIT 2.0 curriculum development funding. PKI facilities include two academic colleges, the College of Information Science and Technology (University of Nebraska at Omaha) and the College of Engineering (University of Nebraska-Lincoln) of which the Department of Computer and Electronics Engineering is a member. With 2,500 total students engaged in IT in programs leading to a Ph.D., the PKI forms a powerful educational entity with considerable regional outreach and has strong corporate support, approaching \$250 million. In addition, through its

Technology Development Corporation, PKI is affiliated with the Scott Technology Center, which is a technology park within the PKI complex.

As envisioned in the initial proposal, the UNO College of Education took an aggressive educational leadership role in the teacher professional development and lesson development efforts in SPIRIT. That expertise is now focused on the curriculum development efforts for the SPIRIT 2.0 project and the related DRK12 funding, but teacher professional development continues. In many ways, this represents an important sustainability step for the project, since the SPIRIT educational effort continues to grow and evolve under the direct collaboration and interest with teachers. The College of Education is well suited for this management role and project sustainability, and has undertaken successful curriculum and teacher professional development projects for the past fifteen years beginning with NSF funding as a Center of Excellence in Research, Teaching and Learning (1995-2000). Additional leadership was also undertaken in a NSF Urban Systemic Program (2000-2005). The UNO College of Education has also received national awards for its curriculum work, including the Great City Schools Leadership Award (2004) and the NASA Mission Home Award (1995).

During 2011, the SPIRIT project also established a nice working relationship with the Nebraska Advanced Manufacturing Coalition (NAMC) and their STEM outreach project, called “Dream It - Do It”. In this new collaborative effort, the NAMC is already funding a large set of CEENBoTs for ten different rural school districts and expects to fund more schools as the project evolves. Lead teachers from each of the first ten districts have now been trained (again at NAMC expense). These teachers will undertake selected SPIRIT lessons and activities, in support of their classroom educational robotics integration, as well as our curriculum pilot testing and field-testing efforts. A brochure announcing this important partnership, as well as information about the NAMC and its business and industry representation, is included in the appendix of this report.

Project Activities and Findings

1. Describe the major research and education activities of the project:

Technical Research in SPIRIT:

While undertaking the early SPIRIT educational robotics efforts, our team found that there were some significant limitations to the educational platform that we were originally using, that of the TekBot from Oregon State University. Although realistic from a computer and electrical engineering perspective and able to indeed add scrounged electronic parts, the TekBot was far too brittle for the rough handling of middle school students, and the small size of the TekBot made adding new components difficult (such as a robotics arm). During the last year of the ITEST project, and continuing with the DRK12 efforts, we have designed our own “open source” educational robotics platform called the CEENBoT (Computer and Electronics Engineering Robot) and we are continuing to improve and refine the CEENBoT as part of the continued SPIRIT 2.0 effort.

There has been significant research and design progress on the enhancements to the CEENBoT educational robotics platform and its technical options, during the SPIRIT teacher professional development efforts, and now into the further curriculum design efforts. The CEENBoT represents the development of a more rugged and flexible platform for student experimentation and enhancement. It can include different chassis features (wheels, supports,

etc.) as well as different microprocessors and sensors. There is now a 324 CEENBoT that is currently available as well as a new ARM 9 version. The 324 CEENBoT includes a number of operating modes for different levels of K-12 education: wireless remote controller, bump bot operating mode, Application Programming Interface or API (in beta test stage), TI graphing calculator mounted on a CEENBoT (in beta test mode) and an open source Graphical Programming Interface (GPI). Both the 324 and ARM9 were designed to accept a Global Positioning System (GPS) for GPS navigation activities. The ARM9 was chosen for its ability to operate with a Linux based operating system. Providing a robotic platform with an open-source operating system such as Linux opens the base of peripherals and applications to those more commonly suited to computers. Typical peripherals supported include WiFi wireless networking, CMOS cameras, keyboards, etc. This ARM 9 CEENBoT includes a new Lithium Iron battery supply with longer run times through a more reliable and energy efficient circuit design, compatibility with Lego Mindstorm sensors, icon driven programming options, LabVIEW compatibility, interchangeability of the ARM family of microprocessor platforms, an enhanced graphical programming interface, and simpler assembly options in kit form.

In addition, work is underway to establish a more rigorous production process for the CEENBoT and to refine the educational robotics technical tutorials, schematic diagrams, and instructional videos/clips associated with building the CEENBoT. These technical resources, like the educational lessons, will soon be deliverable to teachers within the flexible online retrieval environment that helps teachers to select the technical documents that are the most relevant to their educational context and to their classroom goals. It is important to note that the technical research surfaced in the early SPIRIT efforts as a result of significant problems with the TekBot rather than as an initial goal in the project. However, we feel that the transition to the CEENBoT and its continued development has been a very important and very positive outcome of SPIRIT to date. The CEENBoT platform has been widely embraced and there continues to be a waiting list of delivery orders.

Modular Lesson Development and Cyberinfrastructure:

As mentioned earlier, the SPIRIT cyberinfrastructure is continuing to be designed around a unique modular and flexible approach to lesson retrieval for teachers related to educational robotics. This cyberinfrastructure was initially conceptualized by teachers undertaking SPIRIT professional development, and is now being refined in the SPIRIT 2.0 curriculum development efforts as funded by DRK12. In the SPIRIT cyberinfrastructure, the Science, Technology, Engineering, and Mathematics (STEM) disciplines are being integrated through the instructional use of robotics that strongly support the learning of STEM concepts that are already taught at the middle school level. Thus, the SPIRIT robotics curriculum is being mapped to curriculum "touch points" where teachers can use robotics to illustrate middle school STEM concepts, such as an algebra teacher teaching the concept of slope while investigating the steepness of a ramp that a robot can successfully transverse. A total of more than 260 lessons (along with support materials) have now been fully developed and are resident in the SPIRIT cyberinfrastructure system, which is continuing to be refined. This new cyberinfrastructure system, as well as the lessons and materials stored within it to date, are more fully described later in the results section of the report. A core set of lessons relate to introductory algebra and middle school science, and many of the lessons involve a variety of integrated STEM concepts. Lesson development will continue into the SPIRIT 2.0 efforts, and lesson pilot testing and curriculum field-testing is also being undertaken as part of the

curriculum development efforts. STEM topics are also being added and expanded as the current SPIRIT lessons are further tested and modified for efficiency within the cyberinfrastructure environment.

The SPIRIT lessons are using a modular design created by the education team (referred to as the AEIOU method) that allows for the lesson components to be interchangeable and selected by teachers based on individual lesson needs. The AEIOU components include A- Asking Questions, E - Exploring Concepts, I - Instructing Concepts, O - Organizing Learning, and U - Understanding Learning (or assessment). With this AEIOU strategy, a well-established base of critical and well done lesson components will allow for a flexible retrieval of lessons and lesson components, as desired by a teacher using the curriculum. The AEIOU method allows a user to select individual components of lessons within a five-part model of lesson plan construction, so that each component can stand alone, or can be easily removed from a lesson if desired by a teacher, or can even be replaced with a component of the same type, for a slightly modified lesson. A sample lesson is included in the appendix. The AEIOU lesson components are further detailed in the following description.

SPIRIT Lesson Format:

- A** – Asking questions: This component is designed to facilitate an initial classroom interchange of questions and ideas. An **A** component may include a prompt-type question in an engineering or scientific format as a model of good questioning. These **A** components may also include video clips, graphs, scenarios, and other hooks to empower students to become curious and ask questions.
- E** – Exploring concepts: This component helps students to study, experiment, conjecture, and to instructionally play with the robotics equipment in the context of the questions that were asked in the **A** component.
- I** – Instructing: This component is the key component of the lesson plan and is designed to instruct students in the formal core processes of the STEM topic that they are studying. Many of the **I** components are designed to service a broad range of grade levels by separating topics into vertically articulated units: *recognizable* terms, *conceptual* terms, *mathematical* terms, *process* terms, and *applicable* terms. For example, beginners might explore a topic like slope through *recognizable* terms such as “steepness” whereas advanced students might touch on the *application* of slope by exploring changes in slope based upon what they see the robot do during ramp or various movement experiments.
- O** – Organizing learning: This component is designed to allow students to participate in a guided practice environment where they might create graphs, develop charts, solve problems, and make decisions based upon what they have learned from the **I** components as well as what they have observed from their questions and explorations in the **A** and **E** phases.
- U** – Understanding: This component is designed around effective ways to assess how well the various **I** components have been addressed for students. The **U** components include a number of unique assessment instruments that range from short quizzes, games, to tests and worksheets, to projects, to interpretive writing.

The AEIOU lesson components are also being “tagged” and arranged within an electronic database of similar components to fit the needs of an individual instructional topic, or each **I** component. For instance, for a given instructional topic such as *slope*, there may be

many of each of the other vowel components that are tagged to fit that particular *I*. A teacher may chose, at their discretion, from among those components that best fit their needs, guided by the interactive website. Once the individual components have been selected by the teacher, the website will further help the teacher to organize the components into a cohesive set of lessons including all of the ancillary documentation (i.e., worksheets, web links, assessment instruments, etc.) and then print this set of individualized curriculum materials.

The editing process for lessons has been very systematic and extensive. Each lesson is carefully edited, by use of a review team that includes a peer teacher, a content specialist, a professor of learning research, and a technical writer. A diagram flowchart of the lesson writing and editing process is included in the appendix.

The Use of Standardized Test Questions

The SPIRIT project has also integrated released standardized test questions into the assessment options for teachers. The selected sample assessment items are matched to the ‘I’ component of the lesson sections. The matched items are multiple choice items that are selected from released international (e.g., TIMSS), national (e.g., NAEP), and state assessment sources. Permissions are being sought for the use of the items, but many are non-copyrighted. These items are intended as examples of the sorts of questions that can be used to assess student learning in the topic. Future enhancements to the assessment system will also allow teachers to create a customized test of standardized test items. Strategies are being explored and conceptualized that might permit the items to be automatically scored. Such a future system might then provide reports to the teachers on the performance of their students. Most of the ‘I’ components of the lessons will have a set of 3 to 4 standardized test questions associated with them, representing a page of sample test items. A sample page is included in the appendix.

For some of the scheduled field tests in 2012, we will select a pre/posttest from the released items on approximately four topics. Each pre/posttest will comprise 25-30 items on the topic. To ensure the reliability of the assessment instruments, we will run item level statistics (p-value and point-biserial) and test level (reliability coefficient) analyses. Items that perform poorly will be modified or deleted from the final instrument. The test will be administered to students prior to participation in the summer program and at the end of the programs. We will analyze gains in learning from pre to posttest and test for significance (t-test). To ensure that the observed gains are attributable to the intervention, rather than just test/retest effects, we will also administer the pre/posttest instrument in another summer program that is not focused on the topics covered in the field test. The time between the pre and posttest will be the same as for the intervention group. Then learning gains for the intervention group can be adjusted for the test/retest effects.

Professional Development with Teachers:

As part of the original SPIRIT teacher professional development efforts and that now forms a foundation for more extensive curriculum development in the DR K12 project, survey research was conducted with 97 teachers that attended the first three years of the initial SPIRIT professional development efforts, as well as 21 teachers that attended a fourth year of professional development in Columbus, Nebraska. The fourth year of professional development at Columbus was undertaken at no cost to NSF, at Central Community College, due to a grant that they received from the Nebraska Department of Education. Another 93 teachers participated in SPIRIT related graduate classes at UNO. Another 94 teachers have been trained

in multi-day individual school efforts, and supported by organizations such as Dream It Do It. Thus, a total of 305 teachers have now participated in either an extended summer workshop, in multi-day school-based sessions, or in a project-related graduate course. Such trainings are continuing to expand the base of the SPIRIT teachers able to contribute to curriculum development, as well as pilot testing and field-testing efforts. The ongoing strategy of these teacher professional development sessions were to introduce the teachers to engineering principles and basic electronics, as well as to show them how to construct the robot and to generate lessons ideas and draft lessons for incorporating educational robotics into their own STEM instructional responsibilities. Topics covered included problem based learning; the educational advantages of STEM integration; the discipline of engineering; a comparison of the scientific method to the engineering process; the engineering design process; engineering design tools; and the use of an engineering notebook. Other more technical topics covered included assembly of the robot itself; electrical circuits; motors and electrical components (such as resistors and capacitors). The results of these professional development activities, related to teacher perceptions, are provided in the results section of the report.

Data Collection with SPIRIT Students and Comparison Groups:

Continuing in 2011, the SPIRIT project has collected a range of data with students both during the early teacher professional development efforts and the later field test efforts, to help to examine whether the educational robotics lessons are having any impact on student achievement. The SPIRIT project is now refining and expanding this student data collection effort as a more systematic curriculum pilot testing and field-

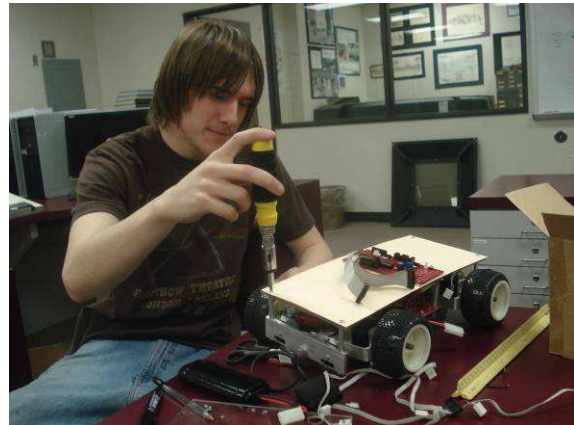

testing process, building upon what was learned in the early pilot testing of early draft lessons. The results and discussions of these data analyses are included in the results section. The data analysis activities that have occurred with students to date are summarized below, and are separated by efforts undertaken early in the project, and the more sophisticated later efforts. Many of these analyses used a control or comparison group, but could not be randomly assigned, due to district restrictions. The results of these initial pilot test analyses are further discussed in the results section of the report and have also been published in several refereed articles, also detailed at the end of the report.

| Initial Pilot Testing (Student Data Collected in the 2009/2010 phases of the SPIRIT Project) | | | |
|--|------------|--|--|
| Type of Student Data Collected | N = | Comparison Group | Results (<i>explained in results</i>) |
| <u>Criterion Referenced Test Scores (CRT)</u> (Compared the CRT scores for students in a teacher's class with school/district) | N=1058 | School and district mean Scores for the same CRTs | Encouraging, but CRT scores for impact analysis was limited, leading to other strategies. |
| <u>Short Duration Pilot – Content/Attitudes</u> (Used content and attitude tests before and after a 4 hour robotics intervention) | N = 141 | Students were own comparison group in a time series design | Significant attitude improvement for STEM was found, after a 4 hour robotics intervention. |
| <u>Math Class Pilot – Content/Attitudes</u> (Examined a full semester mathematics class and eight SPIRIT lessons) | N = 12 | Students were compared to earlier comparison group | Significant STEM attitude and content increases were found, with particular content increases in math. |

| | | | |
|--|--------|---|--|
| <u>Science Class Pilot – Content/Attitudes</u> (Examined a full semester science class and eight SPIRIT lessons) | N = 18 | Students were compared to earlier comparison group | Some improvement, but not significant, on content and attitude assessment instruments. |
| <u>Engineering Pilot – Content/Attitudes</u> (Examined a full semester 9 th grade engineering class and eight lessons) | N = 7 | Compared to control data from the time series design. | Some improvement, but not significant, on content and attitude assessment instruments. |

As the curriculum has continued to be refined, the project has been able to expand the field-test efforts, and to undertake multiple sets of SPIRIT lessons with a particular group of students in a more careful research design. This allows the individual lessons to be refined, along with the curriculum itself.

| SPIRIT Field Testing (Types of Student Data Collected in 2010/2011 Phases of the SPIRIT Project) | | | |
|---|------------|---|--|
| Type of Student Data Collected | N = | Comparison Group | Results (<i>explained in results</i>) |
| <u>Summer 2010 Robotics Field Test</u> (Middle School Robotics Camp compared content and interests assessments in a three day camp) | N=29 | Students were their own comparison (Time series) | Significant increases on a content test, interest test, and survey about future STEM coursework students were interested in taking. |
| <u>Virtual Robotics Test 2010 (Middle)</u> (A Virtual CEENBoT program from 4-H Robotics, was tested in a four day 4-H summer camp) | N = 8 | Students were their own comparison (Time series) | Significant increases on a content test related to seven STEM “big ideas” associated with the program. |
| <u>2010 Nebraska Robotics Expo (Middle)</u> (Students attending the CEENBoT Showcase of the Nebraska Robotics Expo were surveyed for STEM interests) | N = 74 | Students were compared to non-participants in after-school clubs | Significant increases on engineering concepts, science attitudes, problem solving attitudes, and a general assessment of workplace skills. |
| <u>January/Holiday 2011 Robotics Test</u> (Middle School Robotics Camp compared content and interests assessments in a three day camp) | N=37 | Students were their own comparison (Time series) | Significant increases on computer programming concepts, workplace skills, and STEM interest assessments. |
| <u>Lewis & Clark Field Test 2011</u> (Middle School Robotics lessons undertake with two classes of middle school students) | N = 46 | Students were own comparison as well as compared to earlier camps | Significant increases on STEM “big ideas” including variables and engineering design. Significant increases on STEM attitudes also. |
| <u>Summer 2011 Robotics Field Test</u> (Middle School Robotics Camp compared content and interests assessments in a three day camp) | N = 21 | Students were their own comparison (Time series) | Small but significant increases on computer programming and sensors concepts, attitudes toward STEM and interest in STEM careers. |

Further Data Collection with SPIRIT-DRK12 Students (Expanding data efforts):

Moving into 2012, the student data collection and analysis continues as the SPIRIT curriculum development evolves and now expands into more refined pilot and field-testing. Building upon what was learned early in the project, the SPIRIT 2.0 project is now undertaking more extensive educational robotics lesson pilot testing and curriculum field-testing with various sets of lessons. The SPIRIT Project is continuing under IRB approvals (IRB 443-09 EX) for these efforts to undertake more refined pilot and field-testing within the Metropolitan Omaha Education Consortium (MOEC), which is a diverse set of 13 school districts within the Omaha metropolitan area, representing more than 100,000 students. The pilot testing of individual lessons lasts approximately 1-3 hours, while field-testing a group of individual lessons may involve from 5 to 40 hours of instruction, in larger events such as in summer camps or in regular classes within the academic year.

As the SPIRIT pilot testing and field-testing efforts are expanded in 2012, we are building upon what we have learned in early efforts in the project. The lessons that have been targeted for further pilot testing and field-testing will focus directly on core STEM topics already being taught within the typical school curriculum. This pilot testing process, expected to continue during the duration of the SPIRIT 2.0 project, will seek teacher volunteers each semester, within MOEC to pilot test at least three educational robotics lessons with students in their classes. The students will take a pretest and posttest on core robotics-related STEM concepts, as well as an attitude assessment on science, technology, engineering, and mathematics (STEM) interests. The educational robotics lessons will then be refined based upon this feedback. The assessment instruments are from a partnership with the NSF ITEST GEAR-Tech-21 (NSF #0833403) project and have been previously tested for reliability and validity. We are also using released standardized test questions, as well as open form questionnaires scored with rubrics. These assessments are described further in the results section, and represent focused collaboration between the two NSF educational robotics projects.

In support of the initial student comparison group process, in 2009 and 2010 we established a set of classrooms that took the assessment instruments as a pretest-posttest baseline, with no robotics activities to get foundational data for no intervention. This group then took the assessment again after a short educational robotics intervention of about four hours. These “control groups” took the assessments a total of three times, which included taking the assessments one to two weeks apart, and then a third administration of the assessment, after the four-hour mini-intervention, to reward the students and their schools for their comparison group participation. The four-hour intervention essentially piloted SPIRIT lesson components as well as introduced students to educational robotics in a fun, hands-on setting, in which the whole school could participate. This “event” also allowed the project to retrieve data on the effectiveness for the four-hour intervention to potentially impact the STEM content and attitudes of the students. The results of these mini-intervention sessions are described in the results section of this report. This successful control group strategy is being continued for selected efforts of into SPIRIT curriculum testing and refinement process.

Beyond being a reward for the data retrieval process, the series of short-term three or four hour mini-interventions were also conducted with the intent to briefly introduce youth to robotics through the use of hands-on experimentation. While we did not expect such a short duration post-control group session to have lasting conceptual learning, we did expect that this introductory experience might provide some initial excitement for youth about robotics and perhaps even increase their interest in robotics. It also functioned as a recruitment process for further control group sessions and to encourage teachers to be trained in SPIRIT professional development sessions. As the pilot and field-testing continues to expand in 2012, the content and attitude assessments of these longer duration groups will be contrasted with this expanding comparison group of students who do not receive any robotics instruction between the pretests and posttest assessments.

Further SPIRIT Pilot Testing and Field Testing Procedures Plans:

We have learned a lot in SPIRIT about working with teachers and students, which have allowed us to strategically evolve from local teacher professional development to national level curriculum development and refinement. As the SPIRIT 2.0 project undertakes further pilot testing of individual robotics lessons, we are refining our procedures for pilot testing. In these efforts, teachers from the Metropolitan Omaha Education Consortium who have previously

attended a summer SPIRIT Educational Robotics Institute are being asked to volunteer for the lesson pilot testing process, by use of an e-mail to the list of these 305 trained teachers. If a teacher is interested, they send a return e-mail to the SPIRIT project stating their interest, experiences, and general background, which is reviewed by the research team, and if appropriate at teacher is invited to do a well-focused review of the lesson. In this process, we then agree to support the teacher by sending a graduate student to help with activities such as videotaping the lesson, administering some feedback forms, and loaning extra CEENBoTs if needed. This instructional support appears to be enough incentive for teacher participation, since the teacher gets an extra “pair of hands” and some materials to help support the lesson in the classroom.

If selected to participate by the research team for further pilot testing, the SPIRIT teachers are also invited to various Saturday morning meetings, describing the lesson pilot testing process and discussing the approval procedures. If they agree to participate after this overview session, the teachers sign a consent form for pilot testing, along with participating students (and parents). Teachers pilot educational robotics lessons of their choice, from the database of educational robotics lessons (<http://www.ceen.unomaha.edu/TekBots/SPIRIT2/>). Teachers distribute consent forms to their students, to be signed by parents and returned to the teacher, and then to the researcher. Teachers and students complete a short survey feedback form after the pilot testing process to provide lesson refinement suggestions. If appropriate, students may also be asked to take a pretest and posttest on their interests and content, particularly if multiple lessons are pilot tested. If significant work is involved in the pilot testing, the participating teachers may also receive a university voucher for \$100 to sign, which will initiate project payment for their participation in this lesson evaluation activity.

The consent form for pilot testing describes that the educational robotics lessons will be relatively short in duration, interesting to students, and that the lessons will map to standard educational content already within the students’ curriculum. The consent form also provides background information on the possible assessments to be given to the students. These short assessments represent at most, and another 60 minutes of student time. The student assessment instruments that are now being used in the SPIRIT project are well-developed instruments, and represent some significant improvements over earlier instruments used in the early phases of the SPIRIT project. They have been developed in collaborative work with the GEAR-Tech-21 NSF Project, under the direction of Dr. Bradley Barker (NSF #0833403) and have been previously used and validated within a variety of educational settings, summer camps, and after-school programs including previous work within the MOEC area schools (Barker, Nugent, Grandgenett, Hampton, 2008).

In the further field-testing efforts planned the participating teachers remove any student names, on all the assessments, before sending them to the SPIRIT project researchers. They use a numeric ID for the names, such as Student 1, Student 2, etc. However, consent forms will continue to retain the student names when they are sent to the researchers. Thus, consent will be able to be verified by name, but student assessment data will not have any names attached to this information. The pilot testing and field-testing results to date are described later in the report in the various results related sections.

Online Course Development:

An ongoing effort of the SPIRIT project is also to initiate an online approach to teacher professional development, as represented by online graduate courses and online components of in person or blended graduate courses. The online course and course components focus on teaching educational robotics to interested STEM teachers across the nation and for the offering of graduate credit, as a way to extend and sustain the teacher professional development initially conceptualized for the SPIRIT grant. The pilot offering of the online course was done as a face-to-face offering during the summer of 2008 and since then, modifications of the course or its various online module components have been offered through December of 2011, with expectations for more extensive offerings in 2012. Several offerings have used a blended course format (some instruction done in person and some done online). The course is entitled “TED 8010 Seminar in Education: STEM Robotics” and is a three credit hour graduate course designed for any level of elementary, middle, or high school teacher. In addition, “TED 8410 Improvement of Instruction in STEM”, as well as “TED 8970 – IT and STEM Working Connections” have used various online components of the course. Some courses and modules have included the building a CEENBoT from a kit as well helping teachers to develop a set of educational lessons for their own classroom use. Other graduate courses and modules have used the online SPIRIT cyperinfrastructure as a way to have a focused online component for teacher training and curriculum development. Already, the courses and modules, particularly in an online independent study format, are available nationwide, to teachers interested in taking the course, as well as for supporting their learning about the use of educational robotics.

During these graduate course experiences, students are expected to think about STEM and educational robotics teaching, learning and curriculum writing in creative ways, focusing on not only improving student learning, but also on sparking student interest. Another optional activity in the course or course modules is for teacher participants to identify a compatible selection of SPIRIT lessons and to use them with learners. These courses and course components are a model for future course offerings within a national context, which also might involve community colleges. For example, a community college instructor in another state could teach several sessions locally (supporting CEENBoT construction) and a UNO College of Education professor could teach the on-line sessions (supporting curriculum development). The enrolled teacher could get graduate credit from UNO, and the community college instructor could receive an instructional stipend for assisting with robot construction in the course. Finally, this course model will strive to help educators to better understand what it takes to teach with the robots, the advantages of such instruction, as well as the challenges faced for such STEM learning environments.

Virtual CEENBoT Collaboration:

A team from the Global Challenge Project, led by Dr. David Gibson, has created a virtual CEENBoT simulation program that will soon be available and particularly targeted at 4-H organizations. Dr. Gibson is an Associate Research Professor in the School of Social Transformation at Arizona State University. The Virtual Robotics application is a multi-platform software program that has been



developed within the context of an overall curriculum development grant led by Dr. Brad Barker (University of Nebraska at Lincoln) and funded by the National 4-H Organization, that targets providing students with a general introduction to robotics in a virtual world. The application has been developed as an educational game in which students work in a virtual laboratory to investigate the nature of robotics and then build and test a virtual CEENBoT. The students are guided in this process by completing a series of levels that get more challenging. Students must also record observations, their own designs and experiment results in a notebook.

The hub of the program experience takes place in the Virtual Robotics Laboratory, which has tools for youth to use as they explore the program. There are six activity areas in the lab. A *Whiteboard* with a “To Do” list for the current module and to read instructions for the different activities you need to complete. A *Video Screen* to view movies of real-world robots in a variety of settings is available. A *Table* is in the center of the room



where there are virtual books that provide background information in Science, Programming, Engineering, and a *Laptop Computer* with a programming interface. *Computer Kiosks* along the wall hold animations and small simulation experiments, and a *Shelf* along the wall holds robot parts needed for assembling or redesigning a virtual robot.

After the CEENBoT has been built the students first learn to drive it in a manual mode using the keyboard of the computer. Next they learn a basic programming language that allows them to design and develop a specific programmed course of action for the CEENBoT so that it can operate autonomously. These skills are then used in real world situations in the next level. Students undertake specific “simulated” jobs that robots can do such as fire control or uses in agriculture. In these levels, student engineers build virtual features for the CEENBoT that will complete a specific task. Then they develop a program for the CEENBoT that it will execute. The students then test the CEENBoT to see that it performs properly. Once it performs as they think it will they move into the game mode to operate the CEENBoT in a simulated real world situation.

The SPIRIT team is excited to continue to work with Dr. Gibson and Dr. Barker to continue to help to refine the virtual CEENBoT program that will have particular applications in 4-H programs across the country. Such virtual robotics experiences may be very useful to teachers in both formal and nonformal learning environments, to help support students with a richer educational robotics experience that blends online and “hands-on” classroom learning activities. Field test results of this program are described later in the report.

2. Describe the major findings resulting from these activities:

Robotics Platform Results to Date:

As described earlier, the work in the SPIRIT project has led us to successfully develop a new educational platform called the CEENBoT. The initial teacher professional efforts with Oregon State's TekBot found that the platform was too fragile for use by middle school and high school students, and that it had structural limitations in the ability to add onto the platform. A prototype of the new CEENBoT educational platform was used with teachers early during the SPIRIT 2.0 grant. Since then it has evolved to a simple, durable, flexible and feature-rich learning platform. The CEENBoT is more compatible and flexible for the inquiry-based use and rough handling of students. The versatility of the platform also allows for a diversity of classroom and independent learning environments including in-school, afterschool, at-home and university instruction. The CEENBoT offers a modifiable platform with many non-proprietary off-the-shelf (OTS) electronic hobbyist components for supporting a diversity of possible user-enhancement activities ranging from hardware implementation, operational investigations, design experimentation and software language development. We designed the CEENBoT with features such as high-quality precision motors, an AC charger, interchangeable drive wheels, wireless remote control capability, large prototyping board for enhancement and experimentation, peripheral interfaces for communication, and various programming options. CEENBoTs are packaged as kits, partially completed or fully completed robots. Peripherals and software for the CEENBoT are in various stages of development, and include add-on GPS, graphing calculator interfaces, alternate wireless controls, an on-board video camera, robotic arms, and graphical programming interfaces.

In the SPIRIT project's continued efforts at refining the CEENBoT platform, we are striving for the development of a reliable robotics educational platform that is ready to be produced at a low cost, and that can be supported by a cyber infrastructure-based curriculum. This is a challenging undertaking, but our progress has been steady, and our foundational work in the SPIRIT project has served us well in refining the platform. We have identified and resolved technical issues as the CEENBoT has been introduced into the grade 5-12 classrooms. The CEENBoT has also been incorporated into Electronics and Engineering coursework at the University of Nebraska's Department of Computer and Electronics Engineering, as well as partner institutions that include South Dakota State University, the Rose-Hulman Institute of Technology, Tulsa University and Howard University. Each school is working with us to enhance its educational efficiency and classroom utility.

A number of improvements in software and hardware have been achieved during the NSF funding to support the CEENBoT for national distribution. These CEENBoT platform achievements and further plans include the following accomplishments.

1. We have improved the energy efficiency of the CEENBoT so that the robot will operate for three or more hours of continuous use on a single charge and the charging cycle can be completed overnight. Its long operating time supports many instructional uses in grades 5-12 and for university classrooms as well as for outdoor use, where some robot activities, including GPS mapping, may take several hours to complete.

2. We have reduced manufacturing costs (currently around \$200 per robot) and are designing the successor to the current platform to cost around \$100. Schools in SPIRIT's educational arena are very cost sensitive and reducing the product cost while providing a quality product will help leverage CEENBoT production, distribution and utility for educators. A thorough cost analysis is undertaken quarterly, as we steadily evolve from DRK12 curriculum efforts to national dissemination.

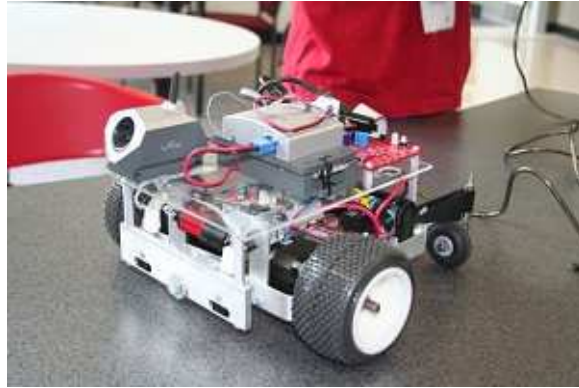

3. We are improving the CEENBoT to make it as feature-filled and economical as possible. The new chassis design is easier to assemble by students, requiring fewer hand tools and time to complete. The design uses a stamped and folded aluminum chassis, anodized to produce a bright, appealing color, a harder finish and to prevent the rubbing off of aluminum. The chassis uses new, custom designed wheels with a solid rubber tread for better traction on various surfaces found in educational settings. The CEENBoT electronics have been redesigned to reduce cost, update components, correct performance issues and add new features such as the graphing calculator interface. Firmware has been improved to add more user feedback during charging and use, and to improve reliability.
4. We implemented hardware and firmware to allow the CEENBoT to be controlled by graphing calculators. Our SPIRIT Teachers have embraced this feature with the Texas Instruments' TI-8x family of graphing calculators found frequently in schools and STEM coursework. Graphing calculators are also now allowed for use on the PSAT, SAT, and ACT College entrance exams and AP tests and are quite commonplace for use in grades 6-12 and university coursework. The project's technical team has documented the use of TI BASIC and the communications features of the calculator to

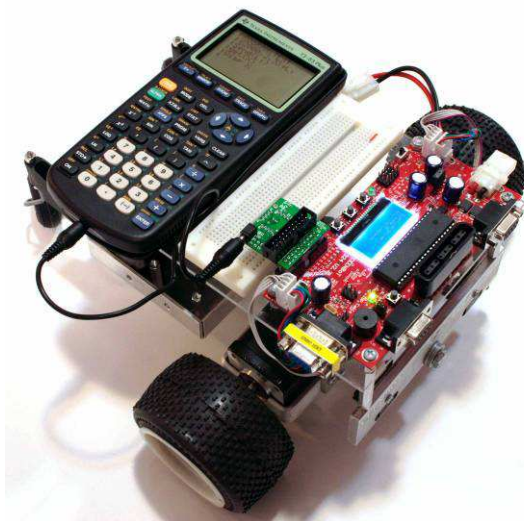

access and control sensors, motors and output devices of the standard CEENBoT model. Graphing calculator compatibility allows the CEENBoT to physically illustrate various functional relationships often only shown visually on the calculator, such as having the robot drive in a path illustrating a sine curve. Controlling a CEENBoT with a graphing calculator opens up the educational use of the CEENBoT to a vast number of teachers and students, who are already

using graphing calculators in their STEM coursework.

5. Our next generation CEENBoT robot design includes a feature to control robots with commercially available smart phones. Several school districts have already approached us about the use of smart phones with the CEENBoT and the Department of Homeland Security has shown interest in funding some of our evolving research. For the CEENBoT, utilizing an existing platform like a smart phone, provides inexpensive educational access to common smart phone features such as GPS, mega-pixel cameras and custom programmability, allowing the educators and students to utilize a wireless off-the-shelf controller like a cellular phone. The SPIRIT technical team is developing prototypes of the interfaces, I/O controller boards, and software.



6. We are working to make the CEENBoT as environmentally friendly as possible and we are very sensitive to the need for environmentally friendly features. One of the rapidly changing technologies that we are addressing is battery chemistry. The early CEENBoT platform, initially developed by University of Nebraska students, used Nickel Cadmium (NiCad) batteries. NiCad battery technology has drawbacks including memory effect due to crystal growth from overcharging, and disposal considerations when the battery is no longer useful. NiCad battery collection and recycling are required under US Federal Law (Material Safety Data, 2007). Every bad CEENBoT NiCad battery-pack would require the disposal of half a pound of toxic battery waste. Battery technologies employed on the CEENBoT now include Nickel Metal Hydride to replace the NiCad packs on the current 324 CEENBoT and Lithium Iron for new generation CEENBoTs. These batteries are less toxic to the environment as they do not contain the heavy metal Cadmium. We are proud of this new “green technology” refinement of CEENBoT battery use.
7. The CEENBoT team has completed version one of a graphical programming interface that allows students or educators to program the CEENBoT in a simple, intuitive, visual development system. The first release of CEENBoT Commander supports many programming features of variables, looping, conditional execution, mathematical functions and reusable modules. It also enables access to the various robotic sensors and inputs such as proximity sensors, switches, and wireless remote controls, and control of robot features such as motors, servos, LCD display, LEDs, and sound.

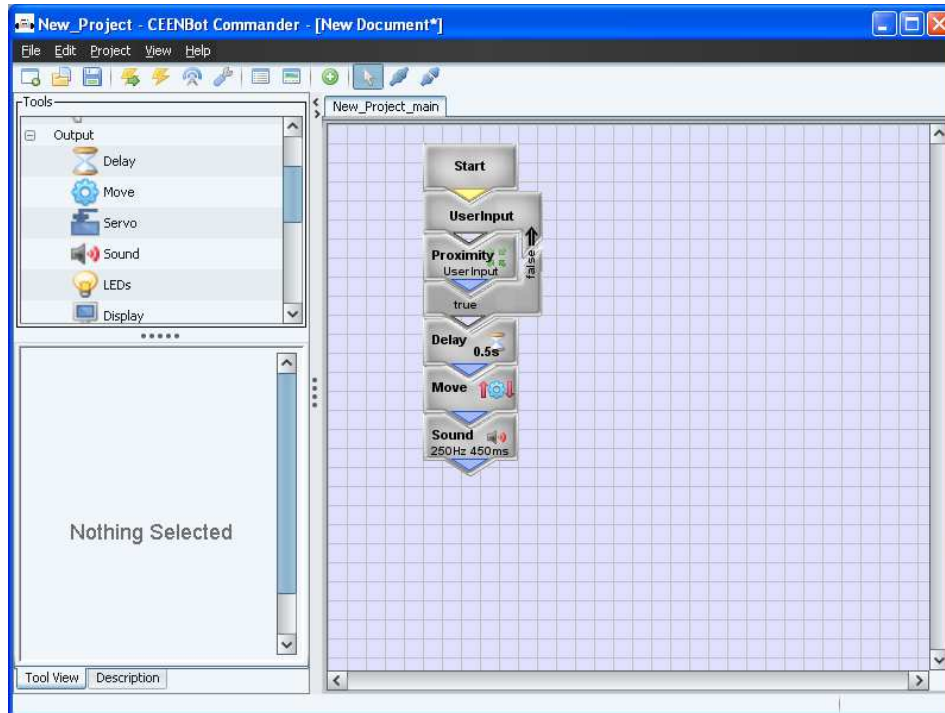

The graphical programming environment runs on both Microsoft Windows and Apple OS X operating systems. An experimental version of CEENBoT Commander produces XML code for use with our next generation ARM-based microcontroller robots. Future development of the graphical programming environment will add features to improve classroom setup, add more complex programming capabilities, have improved error handling, and allow more flexible installation options.

8. We offer partially completed kits or fully assembled robots to educators to meet their curriculum needs. We produce and publish on-line and print documentation for robot assembly and use. We offer programming tools and documentation, and robot design white papers on-line. Our fundamental desire is to make the CEENBoT as flexible, engaging, useful, and efficient for educators as possible, in support of an overall goal of enhancing student STEM education.
9. We are developing a number of accessories to the base CEENBoT. We have written a proof of concept menu system that stores several firmware files on the CEENBoT, and allows selection of a desired firmware file from a list. The production release of this software will enable students to change the CEENBoT in seconds, from a remote control device, to a graphing calculator robot, or to a robot running their own program. In addition, this menu system will allow transfer of new firmware versions into storage using an inexpensive USB to serial interface cable, reducing the cost of programming a CEENBoT by 50%.

Several add-on sensors are in development to extend the flexibility of the CEENBoT. For example, we have prototyped an ultrasonic module to sense objects at distances up

to 20 feet, a color sensor module to follow lines and to determine color of marks under the robot, and a GPS module to receive satellite position information.

- Based on what we have learned with the CEENBoT robot and feedback from users, we are developing a new educational platform called USA (Universal Standard Architecture). The concept of USA is to provide a number of small, interchangeable processor boards containing one of several different manufacturers' microprocessors, a standard socket that holds the processor board, and a series of expansion boards for prototyping, input and output, and display. The boards mount onto an extruded aluminum plate for rigidity and stability, and the aluminum plate becomes the base for an electronics workstation, a robot, or whatever else the student or user might imagine. Initial prototypes of the new USA system are being tested now, and the first versions will be used and refined in college level electronic engineering classes beginning spring 2012, with later use in the K12 environment after refinement.

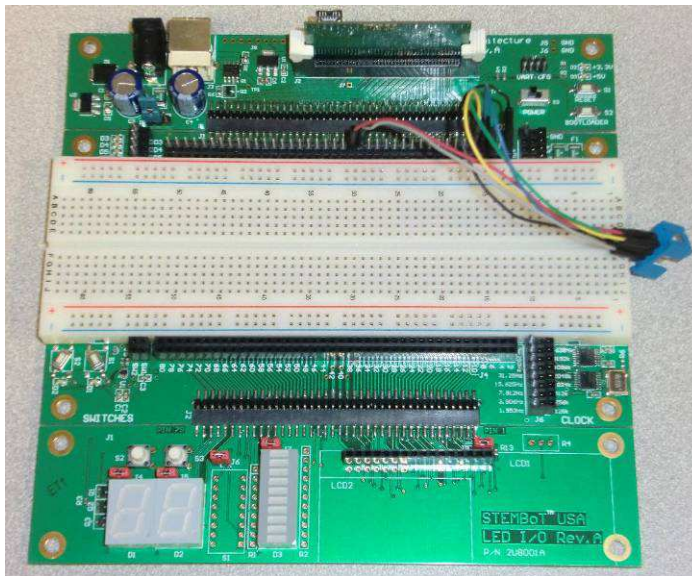

a standard socket that holds the processor board, and a series of expansion boards for prototyping, input and output, and display. The boards mount onto an extruded aluminum plate for rigidity and stability, and the aluminum plate becomes the base for an electronics workstation, a robot, or whatever else the student or user might imagine. Initial prototypes of the new USA system are being tested now, and the first versions will be

used and refined in college level electronic engineering classes beginning spring 2012, with later use in the K12 environment after refinement.



Graphical and Other Programming Interface Results to Date:

The need for enhanced programming capabilities, as well as a Graphical Programming Interface (GPI) capabilities for the CEENBoT was identified by the various cohorts of SPIRIT teachers attending the many professional development workshops. These programming enhancements were considered to be particularly helpful with middle school student use, as well as the overall K16 utility across student levels. Work started on the enhanced programming capabilities of the CEENBoT in the last two years, and will continue in the 2012 SPIRIT efforts. As of 2011, a GPI has been developed and tested and is now in a refinement mode. It is currently compatible with both Windows and Mac computers. It permits the programming of the CEENBoT in starting from “drag and drop” along with C, Java and Assembly. It also helps to facilitate the addition of new sensors and other hardware modules. The GPI is unique in that it will simultaneously connect the various sensors and modules to the base platform while also allowing for multiple programming languages to be used that are appropriate to the level and language of interest of the schools. The CEENBoT now contains relatively sophisticated programming capabilities, as discussed later in this section in various subsections.

As of December of 2011, the CEENBoT programming development efforts essentially address the goal of providing a seamless, user-friendly interface for programming the CEENBoT robotics platform. The GPI project has realized several key milestones, including the design and prototype of an in-house GPI software application called “The CEENBoT Commander”. The CEENBoT Commander is the tool that can be used by students to create programs for the CEENBoT. It features a graphical interface which students can use to create flow-chart like programs that are capable of being compiled and uploaded onto the CEENBoT. Special care has been taken to emphasize interface simplicity and to ensure that students cannot destroy their program accidentally.

The CEENBoT Commander is a Java-based Integrated Development Environment using a customized and designed graphical programming language developed by the technical team and some University of Nebraska Computer and Electronics Engineering students. It offers a way to graphically and textually edit CEENBoT programs from a PC or Mac. The narrative that follows provides additional details related to the CEENBoT Commander and other programming capabilities. The software was designed to interface with ARM7-type and ARM9-type microcontrollers, the centerpiece of the CEENBoT hardware updates. The example graphic provided is the CEENBoT Commander Splash Screen.

The CEENBoT Commander Integrated Development Environment (IDE) allows users to drag and drop programming elements for creating stimulus-based robot program logic flow, using intuitive block elements.

In order to provide a bridge between the CEENBoT Commander’s



simple graphical block programming and the more formal C-language programming, an option also exists to view textually, the behind-the-scenes C-code generated by the graphical program. This feature adds rich educational value to the platform in that while it allows inexperienced programmers to quickly create programs for the CEENBoT with no prior programming experience, the C-code view then helps them to learn how the program would be written in C as they progress in programming knowledge and skills.

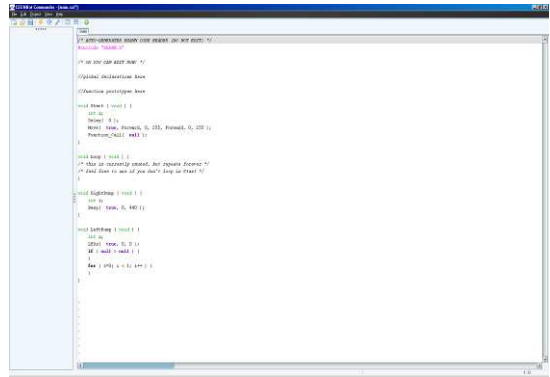

Thus as of December 2011, the computer interface innovations developed for the CEENBoT include the following: the Graphical Programming Interface (GPI), the Application Programming Interface (API), and the TI Graphing Calculator Interface. They are summarized in the chart below, and detailed descriptions of the progress on each in the grant now follow.

| CEENBoT™ Mobile Robotics Platform Programming Options | Description | User Audience |
|--|--|--------------------------------|
| CEENBoT™ Commander Graphical Programming Interface (GPI) | A graphical drag and drop Integrated Development Environment that allows inexperienced programmers to link graphical programming elements together to control the CEENBoT™ | K-12 (Elementary +) |
| TI Graphing Calculator Interface | An interface that allows commands on the TI graphing calculators to be used to program the CEENBoT™ | K-12 (Middle School +) |
| CEENBoT™ Application Programming Interface (API) | An extensive suite of CEENBoT™ specific C-functions designed to simplify interaction with the CEENBoT™'s firmware and hardware | K-12 (Advanced) and University |

The CEENBoT Application Programming Interface (API)

While the primary motivation for creating the CEENBoT API was to simplify the details needed to program the CEENBoT, a secondary motivation was conceived in an attempt to serve the need for compiling and uploading programs that had been created graphically by the CEENBoT GPI. Thus the CEENBoT API originated as a need for a killer application to be created to program the CEENBoT platform with both a graphical language (GPI) and a sequential language (C).

The CEENBoT API allows a user to write programs in C in a manner that simplifies control of the CEENBoT platform. The CEENBoT API forms the primary core and foundational component that also enables other software technologies to write programs to the CEENBoT, including, the GPI (The CEENBoT Commander) and the CEENBoT TI Interface. This idea is conveyed in the Figure on the next page.

CEENBoT Programming Platforms

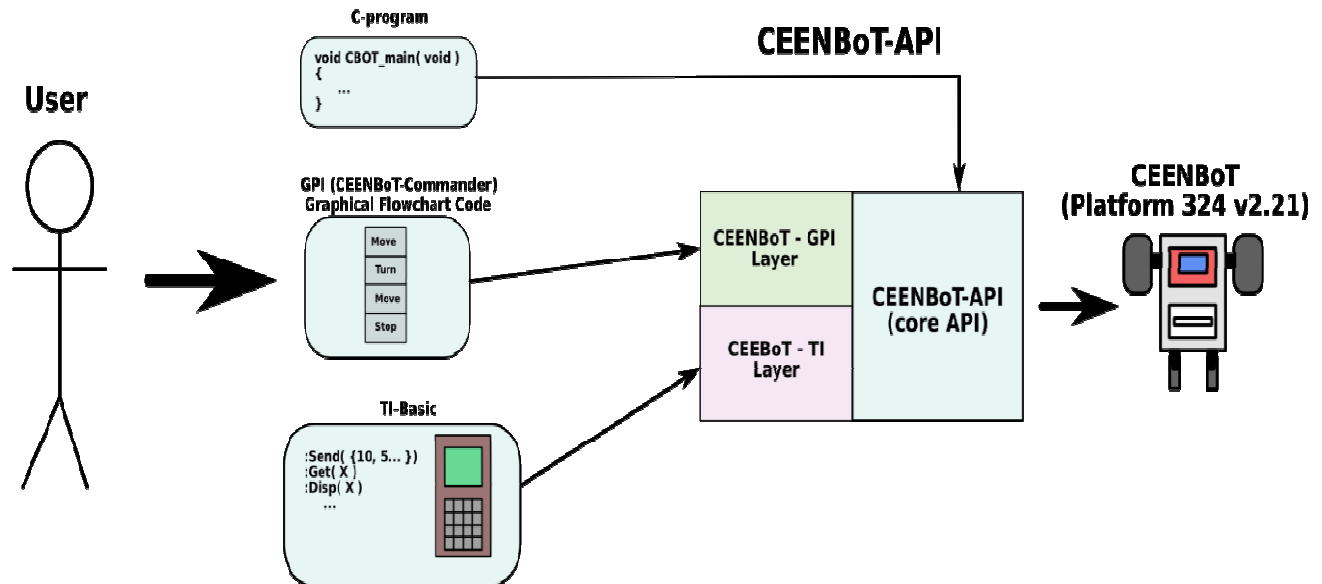

The CEENBoT API is a static library that is used in conjunction with the C compiler (AVR-GCC) that targets the CEENBoT's AVR microcontroller architecture. It is essentially a collection of C functions pre-compiled into a single static library file.

The CEENBoT API exposes a rich set of functions that allows users to control and manipulate the CEENBoT™ in a simplified manner via well-documented function calls. The API functions allow various hardware resources available on the CEENBoT to be easily manipulated. Some of these resources include peripherals embedded on the microcontroller unit itself, such as control of I2C (or TWI), SPI, or UART. Or, the CEENBoT's on-board peripherals can be controlled, such as writing to the graphical LCD display, flashing LEDs, and driving stepper motors.

Users can take advantage of the API library's extensive set of functions (over 220) to write embedded programs that control the CEENBoT without the need for intimate knowledge of its electronics or firmware. This allows the user to focus on actions, while the API handles the details.

A user's program links with the API static library and uses the AVR-GCC compiler to generate a HEX file that is uploaded (or flashed) into the CEENBoT's microcontroller's memory. This idea is illustrated in the next figure on the following page.

CEENBoT-API Programming Paradigm

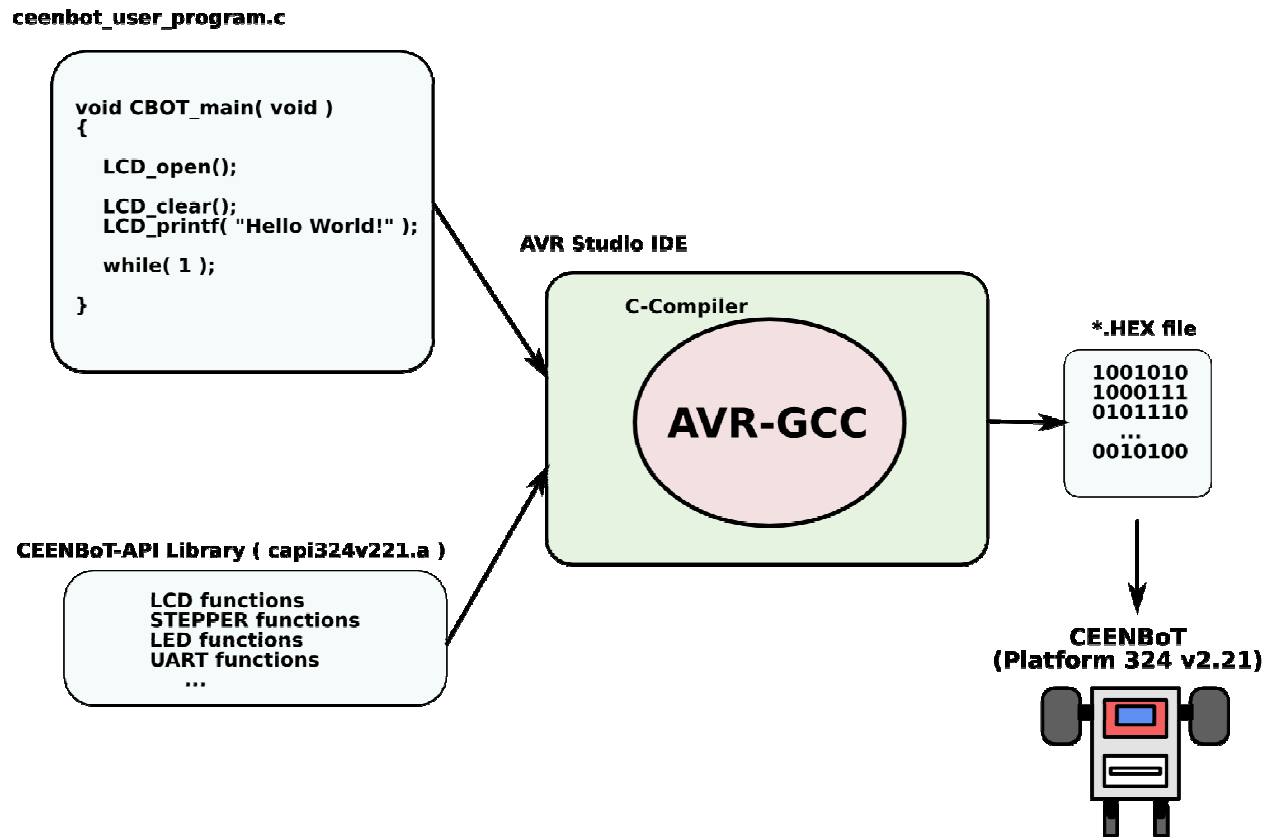

Presently, CEENBoT programming in C is done using the AVR Studio IDE (Integrated Development Environment) which is made freely available by ATMEL. The functions in the CEENBoT API library are grouped into functionally-related units called modules. Each module is in charge of acquiring the necessary resources (such as memory, I/O port pins, and peripherals) to achieve a task or control a particular peripheral device. The current functional modules available through the CEENBoT API include those listed below, and more are being developed:

ADC – Provides supporting functions for using the onboard Analog to Digital Converter (ADC) peripheral.

ISR – Provides supporting functions for declaring interrupt service routines (ISRs) which may also be used by other modules or user defined.

LED – Provides supporting functions for writing to the on-board LEDs.

LCD – Provides supporting functions for writing to the on-board

graphical LCD display.

PSXC – Provides supporting functions for communicating with a Sony PlayStation2® (PS2) type controller using the on-board PS2 controller connector.

SPI – Provides supporting functions for using the serial peripheral interface (SPI) on the microcontroller unit.

STEPPER – Provides supporting functions for controlling the CEENBoT's stepper motors.

SWATCH – Provides supporting functions for using the stopwatch module, which can be used to measure time in units of 10us/tick.

TINY – Provides supporting functions for peripherals under direct control of a secondary supporting microcontroller unit, which on the CEENBoT is the ATtiny48. The TINY is used to acquire the state of on-board push-button switches, attached RC servos, and acquire the state of on-board Infrared sensors on the CEENBoT.

TMRSRVC – Provides supporting functions for millisecond accurate timing services.

UART – Provides supporting functions for using the on-board UARTS in asynchronous mode.

USONIC – Provides supporting functions for using the Ping Ultrasonic sensor by Parallax, an optional peripheral used on the CEENBoT for Mobile Robotics courses.

The next figure on the following page illustrates the modular breakdown of the CEENBoT API and its subsystem modules. Note that while this figure illustrates the modular organization of the API, the entire API itself is encapsulated into a single static library file.

The advantage leveraged by the CEENBoT API can be conveyed by considering that the STEPPER subsystem module alone encompasses close to 2000 lines of code. A considerable amount of work would be required if the user is expected to do this work alone by writing similar code 'bare-metal' style to control the CEENBoT's motors. The CEENBoT API allows users to program without having to directly manage all the intricate details of the CEENBoT's electronics.

Modular Structure of the CEENBoT-API

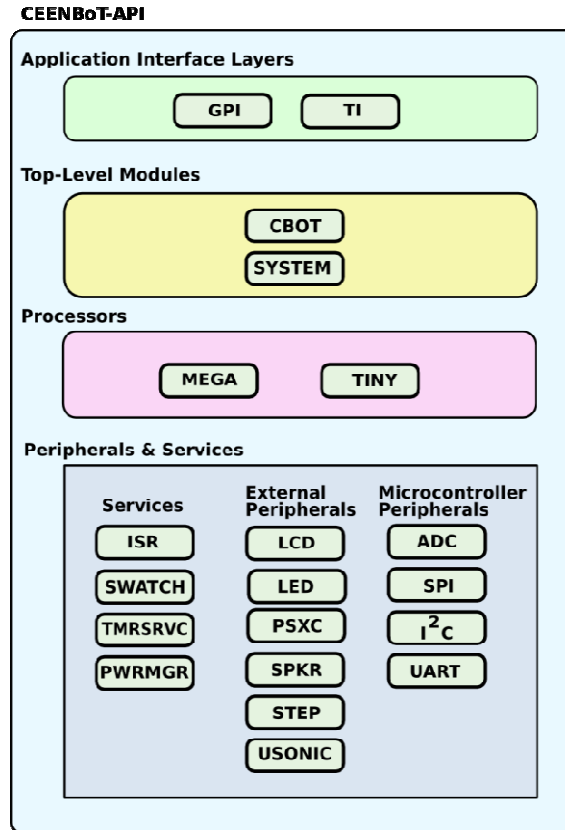

The functions of the CEENBoT API have been well documented to invite and entice users who would engage in C programming to explore the CEENBoT. Available documentation includes a “Getting Started” guide, along with a more in-depth 158 page “Programmer’s Reference Manual” that contains descriptions of all available functions and code examples. These resources allow ease of implementation in the classroom and immediate exploration. In addition, the API serves as the foundation for the other CEENBoT programming technologies including the CEENBoT Commander (GPI) and the TI Calculator Interface, which provide additional means to entice K-12 users (as well as instructors) into the world of STEM courses.

The CEENBoT Texas Instruments® (TI) Calculator Interface

A secondary software technology made possible by the CEENBoT API is the CEENBoT TI Calculator Interface. The CEENBoT TI software interface consists of a thin software layer that sits on top of the CEENBoT API. It allows a user to connect a number of Texas Instruments graphing calculators to the CEENBoT with the appropriate interfacing hardware. The TI interface allows users to write programs on their TI calculators using TI-BASIC (an interpreted programming language used in nearly all Texas Instruments calculator models) in order to control the CEENBoT and have it perform various tasks, just as they would if they were writing programs with the CEENBoT API using the C programming language. The TI interface provides, yet, another option that invites exploration of the CEENBoT robotics platform in an open-ended and intuitive manner for the K-12 audience.

Documentation for the TI Calculator Interface is available in the form of a User's Guide and Command Reference manual. Graphing calculator models supported include the TI-82, TI-83, TI-84, TI-85, TI-86, and TI-89. The TI calculator of choice plugs into the TI/CEENBoT Adapter Board via a TI-communication Link Cable that connects it to the CEENBoT, as shown in the Figure below.



The CEENBoT™ Commander Graphical Programming Interface (GPI)

As mentioned earlier, graphical programming languages are gaining more interest in a variety of fields and industries, and particularly in K12 education. The SPIRIT teachers really desired this capability for the middle school and high school classroom. Graphical programming languages can lower the barriers for entry for those who are not familiar with traditional text-based programming languages, such as C, and allow them to develop programs more quickly and with less training. The high-level elements in a graphical programming language are especially useful for abstracting complicated data transformations. This abstraction encourages the programmer to focus on developing the end application rather than getting mired in, for instance, hardware-level communication issues.





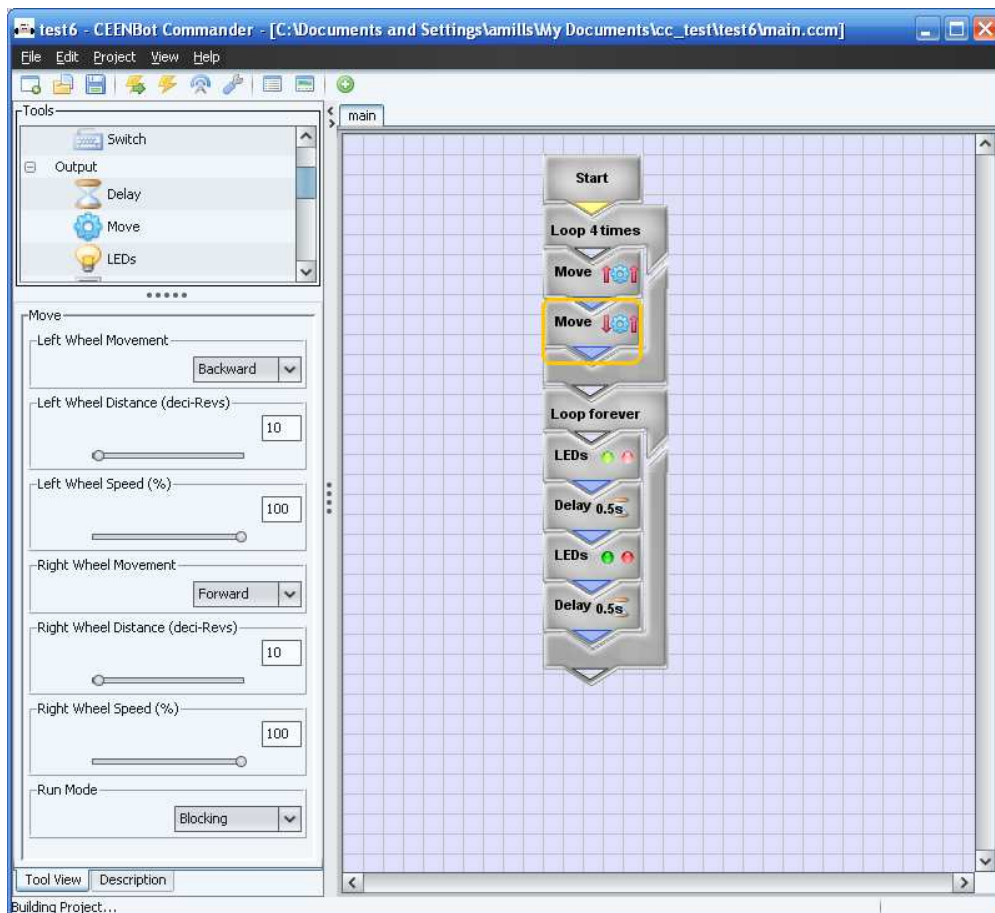

Thus, a graphical programming interface, or GPI, seemed like an ideal tool to get primary- and secondary-school students interested in math, science, technology and engineering. In particular, the goal of the GPI developed was to empower this targeted audience with the ability to program a robot with no background in either programming or robotics. It is a tool designed by an educational institute for use in other educational institutes. As mentioned at the beginning of this section, the Graphical Programming Interface (CEENBoT Commander) is a GUI application program that runs on a PC or MAC which allows users to write programs for the CEENBoT robotics platform using a graphically-oriented, intuitive user interface as an alternative to writing programs in the C programming language. The GPI internally generates code that is CEENBoT API compliant. This CEENBoT GPI code consists of a thin software layer that sits on top of the CEENBoT API.

The GPI efforts essentially began in the fall of 2008 as an objective of both the SPIRIT project and the 4-H GEAR-TECH-21 project for which the CEENBoT would serve as the robotics platform for K-12 teachers, 4-H volunteers, and students. The objective was to simply create a simple graphical programming language interface for users with no programming experience to write programs to control the CEENBoT. After several options, including Arduino, were considered as platform for GPI development, Java was selected as the project language with the intent that a single application could run with minimal changes on both Windows and Macintosh operating systems.

The user interface of the GPI is designed with the intent that the flow of the program can be interpreted without much effort on the part of the user. In other words, the programs that can be built with it should be self-documenting. Tools are dragged and dropped from a list into a work area and then configured using simple input controls, as depicted in the Figure below.

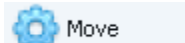
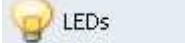

The following is an abbreviated list of the currently available programming tools and their descriptions:

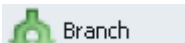
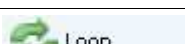
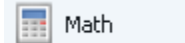
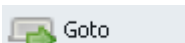
| Tool | Description |
|---|--|
|  BumpLeft | Reads the state of the left infrared bump sensor into a variable. |
|  BumpRight | Reads the state of the right infrared bump sensor into a variable. |
|  Switch | Reads the state of a selected switch into a variable. |
|  Delay | Pauses program execution for a select amount of time. |
|  Move | Sets the desired distance and velocity for the left and right wheels, as well as the run mode (e.g. blocking vs. non-blocking) |
|  LEDs | Sets the state of selected LEDs. |
|  Display | Prints text or variables onto the onboard LCD. |
|  Branch | Allows decision-making based on some condition. |
|  Loop | Allows repeating blocks of code either a fixed number of times, or based on a condition. |
|  Math | Allows basic math functions to be performed on variables. |
|  Goto | Causes the program flow to jump into another loaded module, and then return after it has completed execution. |

For purposes of encapsulation and code-reuse, the GPI allows users to develop a series of independent modules or sub-programs that can then be loaded into the project. These modules are stored on disk as XML, which is both human-readable and conducive to the nested nature of program flow control methods. When it comes time to build the project, each onscreen tool or component is translated into C code based upon its current configuration, and then this code is compiled as normal against the CEENBoT API library. The final result is a HEX file that can be flashed onto the target platform using the GPI itself or external software.

An example program created using the GPI is shown in Figure 5. Program execution begins at the Start tool and travels downward.

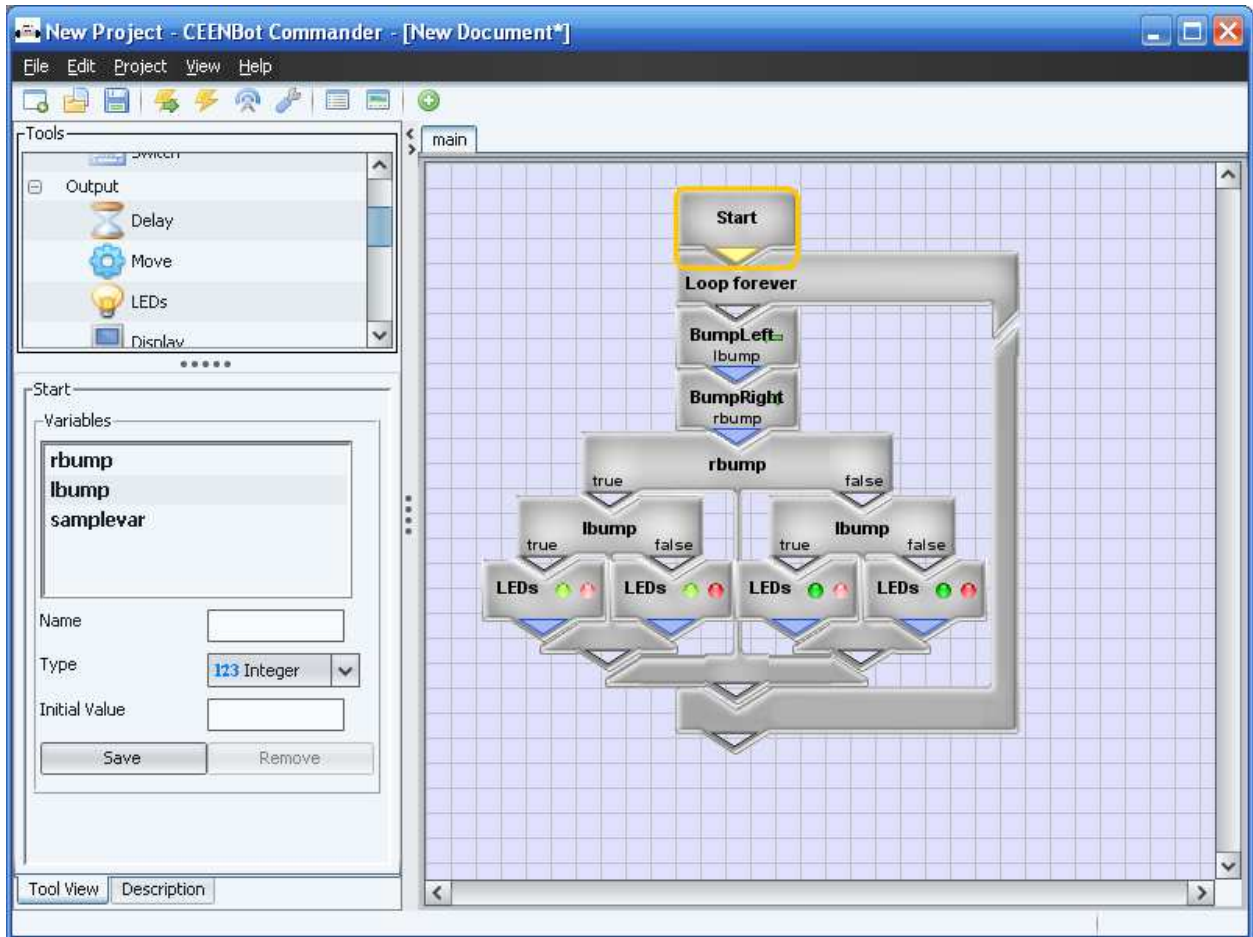

In pseudocode, the program expresses the following:

```

} while( true ){
  bool lbump = leftIRSensorObstructed();
  bool rbump = rightIRSensorObstructed();
  if ( rbump ){
    if( lbump ){ setGreenLED(); setRedLED(); }
    else {setGreenLED(); clearRedLED(); }
  }
  else {
    if( rbump ){ clearGreenLED(); setRedLED();}
    else { clearGreenLED(); clearRedLED(); }
  }
}

```

Even more simply, if we consider Boolean variables {BumpLeft, BumpRight} as inputs and variables {GreenLed, RedLed} as outputs, the program expresses the set of equations:

```

RedLed = BumpLeft
GreenLed = BumpRight

```

As mentioned at the start of this section of the report, it is also possible to preview the automatically generated C code inside the GPI. This was mainly included as a debug mechanism for developers, but may later be expanded upon as a way to simultaneously introduce users to traditional text-based languages, such as C. The C code for the previous example is shown in the next Figure. This is just one example of how GPI developers need to continue to work closely with students and educators to get a clear idea of how they hope to use the software in school curricula. Looking forward, many other exciting tools and features are being planned. One which will probably come up in the near future is scheduling and the capability for multi-threaded programs, something that should be neatly facilitated by the existing chainlike form of user programs.

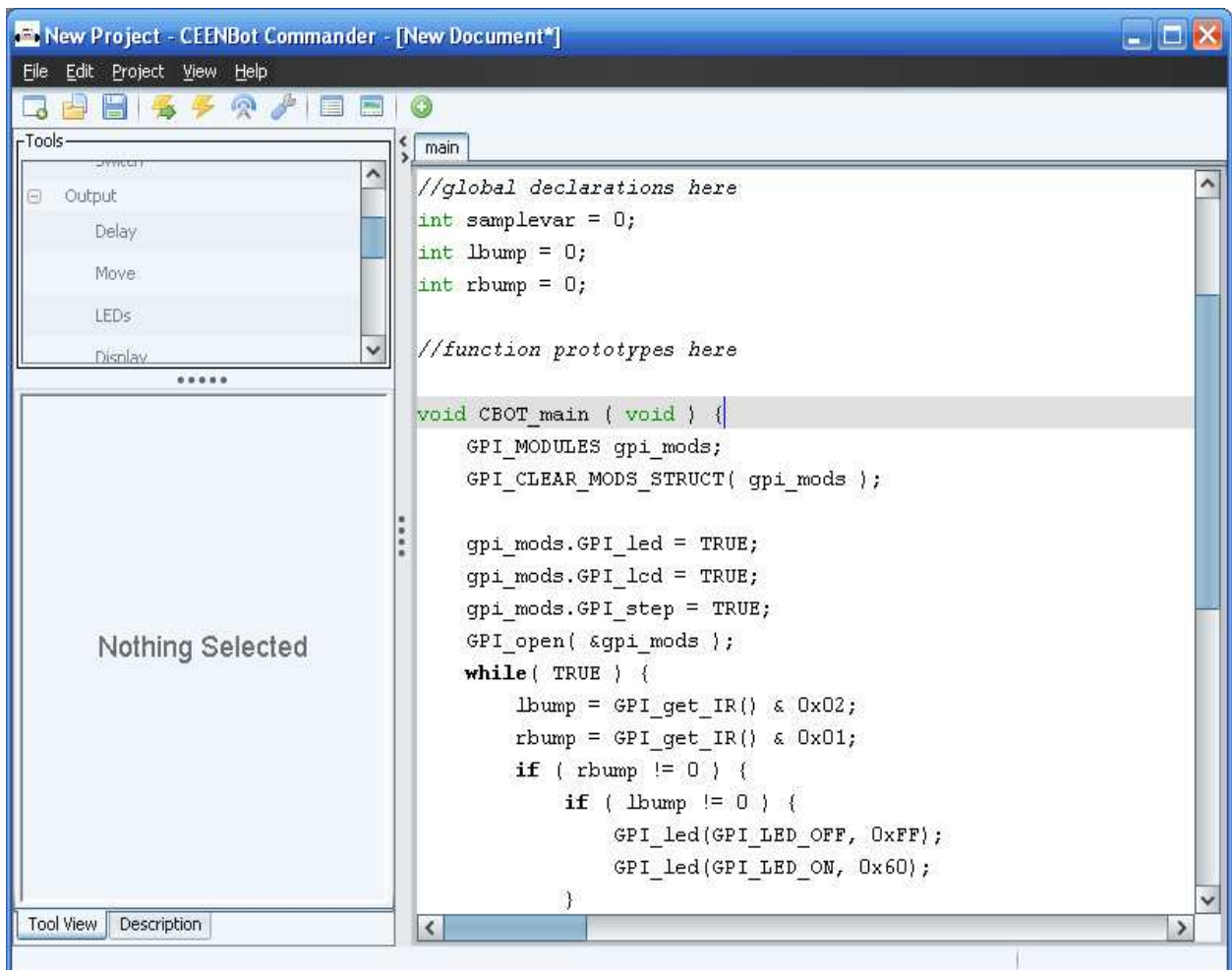

The screenshot shows the CEENBot Commander software interface. The window title is "New Project - CEENBot Commander - [New Document*]". The menu bar includes "File", "Edit", "Project", "View", and "Help". The toolbar contains various icons for file operations and execution. On the left, there is a "Tools" panel with a list of tools: "Output", "Delay", "Move", "LEDs", and "Display". Below this list is a large area labeled "Nothing Selected". The main editor window displays C code for a "main" function. The code includes global declarations for variables, function prototypes, and a main function that initializes GPI modules and enters a loop to read sensor data and control an LED.

```

//global declarations here
int samplevar = 0;
int lbump = 0;
int rbump = 0;

//function prototypes here

void CBOT_main ( void ) {
    GPI_MODULES gpi_mods;
    GPI_CLEAR_MODS_STRUCT( gpi_mods );

    gpi_mods.GPI_led = TRUE;
    gpi_mods.GPI_led = TRUE;
    gpi_mods.GPI_step = TRUE;
    GPI_open( &gpi_mods );
    while( TRUE ) {
        lbump = GPI_get_IR() & 0x02;
        rbump = GPI_get_IR() & 0x01;
        if ( rbump != 0 ) {
            if ( lbump != 0 ) {
                GPI_led(GPI_LED_OFF, 0xFF);
                GPI_led(GPI_LED_ON, 0x60);
            }
        }
    }
}

```

Field Tests of Programming Capabilities and Future Plans for Programming

The beta versions of the CEENBoT API, GPI and TI Calculator Interface were all deployed into the hands of college and K-12 teacher and student users in the fall and early spring semesters of 2010-2011 for feedback purposes. They were received with very positive results. At the University level, the CEENBoT API was used as a foundational element for lab programming exercises in a new 4 credit hour Mobile Robotics course created and taught by

Alisa N. Gilmore in the fall of 2010. The course was comprised of 13 senior and 2 junior students and focused on the implementation of reactive and behavioral-based robotics using the CEENBoT platform. API functions were used as building elements that allowed students to write embedded programs and integrate and control a variety of sensors for AI mobile robotics applications. The feedback from a detailed course survey was very positive. Over 78% of the students in the course agreed or strongly agreed that the API was a means for learning concepts on the syllabus, 71% felt it provided a source of motivation or increased their interest level in the class, and, for 71%, the API provided a sense of personal engagement on the assignments.

The API was also introduced into the introductory CEEN 1030 course taught by Roger Sash. In this course, all CEEN students build a CEENBoT and take it with them for applications in follow-on courses. The CEENBoT API exposed these students to embedded system concepts and basic C programming as students in this class had never taken a programming course, or were concurrently taking their first programming course in Java. The students were able to program the CEENBoT in several lab exercises using CEENBoT API functions with much ease, and were generally very excited to be able to program their robot which they constructed earlier in this course.

The CEENBoT GPI and TI Programming Interface were also introduced to the sustained SPIRIT project K-12 teacher Saturday workshops during the 2010 and 2011. The reception for the user group of approximately 80 K-12 teachers was extremely enthusiastic, even when testing early versions of the software with some bugs present, for which they provided valuable feedback. The teachers were presented with hands-on exercises and told the software wasn't perfect, but to comment on needed enhancements. As a result of the teachers' overwhelmingly positive response, both of these innovations were included as competition categories for their student teams in the 2nd Annual Nebraska Robotics Expo, which includes the CEENBoT Showcase, in its third year sustained from the SPIRIT project. The Showcase was held on February 19, 2011, with K-12 student participants in a number of events that involved the CEENBoT. Included for the first time this year was the Autonomous Maze event in which student teams could choose to use the API, GPI or TI interface to program their robots to navigate tasks in a given course. The Autonomous maze was a success with Elementary, Middle school and High school teams competing and successfully completing the tasks, using all three technologies (Elementary teams even chose to use C-programming with the API).

To help build the utility of programming the CEENBoT for its K16 audience, the programming innovations will continue to be aligned in a progressive sequence of CEENBoT hardware developments and sensor/port capabilities, and refined in CEEN University courses (API), K-12 outreach and field tests (API, GPI and TI interface), and an upcoming roll-out of the 4-H GEAR-TECH-21 project (GPI). The CEENBoT and API are also being tested at collaborating ECE departments to help to further refine it, and to permit a strong "pathway tool" for STEM education that crosses K16 barriers. We are becoming ever more confident that the CEENBoT can be an open source robotics platform that indeed crosses traditional boundaries.

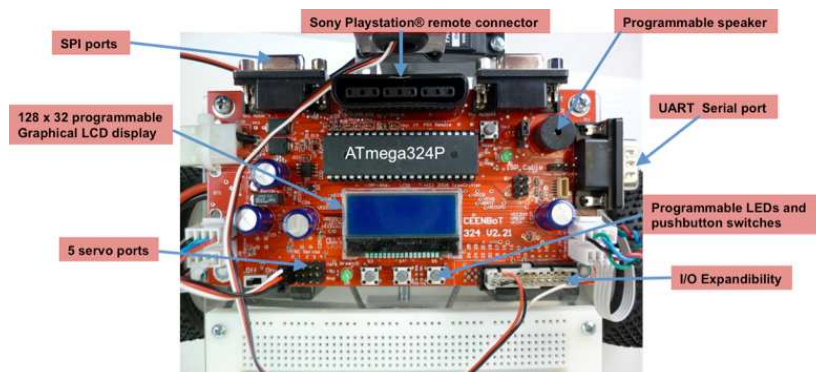

Manufacturing Plans and Marketing Results to Date:

As of December 2011, providing enough CEENBoTs and ongoing updates to meet teacher demand continues to evolve to be a very significant concern for the project, that surfaced initially in the later two years of the first SPIRIT project. In various conversations with administrators in the University of Nebraska system, it was identified that the production of robots could be better supported by establishing a University of Nebraska start-up company to produce the educational robot platform, and was named CEENBoT Inc., and has been endorsed by the University of Nebraska. The university startup company was established in 2009 and is now undertaking a sole source provider agreement with the University of Nebraska to provide educational robots to the SPIRIT project at the University of Nebraska. Additional personnel have been retained to provide engineering technical support to meet existing project orders and to streamline procurement and manufacturing capability. A NSF SBIR Phase I grant (NSF #0945280) was also awarded in November of 2009 that is assisting CEENBoT INC. in these early formative stages, and to help the company produce the first set of robots. As Phase II SBIR grant proposal is being written and is expected to be submitted during early 2012.



Mr. Dennis Deyen is the Chief Technology Officer of CEENBoT Inc. Mr. Deyen has 23 years of expertise in the management of embedded product design and switchgear design for the transmission and distribution of power. He has provided consulting services for the development and production of custom MRI antennas for GE magnetic resonance machines as well as embedded RF solutions. He has a B.S. in Electronics Engineering Technology from the University of Nebraska and has completed a 6-month Management Training course with Best Care EAP and the Small Business Entrepreneur Program from the Kauffman Foundation. Mr. Deyen provides management leadership in the areas of compliance engineering, reliability, design for manufacturability, design for testability and ISO9001 procedures development, providing cost-effective solutions in lean manufacturing.

As of December 2011, significant school district demand for the CEENBoT is already being experienced by the SPIRIT project within the local Nebraska area, and we are gearing up to be able to meet demand on a national scale, which looks challenging but feasible.

Manufacturing efficiencies are being explored to reduce the time to prepare both kits and assembled robots. Construction tutorials and other construction support materials are being placed on the CEENBoT website, and are available to anyone free of charge wishing to build the robot. Consultants are continuing to help to refine current practices and we are undertaking improvements in preparation for ramping up

production to meet the demand of various educational, university and private constituencies. In the interim period, retired faculty and staff are being used to assist in producing the initial parts during the transformation to greater levels of automation.

This is a screenshot of the CEENBoT website. At the top left is the CEENBoT Inc. logo. To the right of the logo is the text "Robotics Solutions for Educators, Hobbyists and Researchers". Below the logo is a navigation menu with the following items: "Construction and User Guides", "Firmware Updates & Tools", "Frequently Asked Questions", "Community Area", "Multimedia", "Development Roadmap", and "CEENBoT Store". The main content area is titled "Construction and User Guides" and contains two sections: "Tutorials and Reference Documents" and "Reference Documents". The "Tutorials and Reference Documents" section lists three PDF links: "Assembling The CEENBoT Chassis v1.06 (PDF)", "Assembling the CEENBoT 324 Robotic Controller Board - v1.00 (PDF)", and "Assembling the CEENBoT Bump Sensor Board - v1.01 (PDF)". The "Reference Documents" section lists two PDF links: "CEENBot 324 User Manual v1.00 (PDF) - for all users" and "Controller Reference Guide v1.00 (PDF) - for users of the wireless Playstation remote". At the bottom of the page is a copyright notice: "Copyright ©2010 CEENBoT, INC - Sitemap - About CEENBoT, INC - Privacy Policy".

As of Fall of 2011, a company with additional national potential for outreach and support of distribution of the CEENBoT, is HobbyTown USA and we are continuing discussions with this organization. They are already assisting our cost cutting efforts by finding lower costs for various screws, bolts, nuts and other attachment items. Given our experience with middle school students and school district involvement to date, HobbyTown USA is also interested in perhaps distributing the CEENBoT in kit form to educators and other customers across the nation. We continue to discuss further possibilities and to consider the viability of this potential partnership and other similar ones.

Current demand and market research, including industry review, education conferences, in-depth interviews and trade references have indicated that the CEENBoT market consists of four segments: K12 schools, colleges and universities, after-school programs (for-profit and not-for-profit) and the private hobbyist industry. The potential educational market includes:

1. Elementary and middle schools
2. High schools
3. ECE (Electrical & Computer Engineering) colleges
4. Community colleges and trade schools
5. After-school clubs and summer camps
6. Hobbyists

Potential future educational distribution possibilities beyond U.S. K16 institutions include Department of Defense (DOD) schools (elementary, middle and high schools), after-school organizations (Girl Scouts, Boy Scouts, Girls Inc.), corporate-backed schools, robotic competitions and corporate education. These various groups particularly include organizations interested in developing their youths' STEM skills and talents by offering hands-on, educational robots for enhancing their students' educational needs. Another distribution and outreach possibility is ECE departments that wish to attract and retain high school students interested in engineering fields and careers, and we continue to expand partnerships with ECE departments across the country. Thus, the student profile being targeted for CEENBoT initially incorporates grades 5-16 with a long-term goal of grades K-16. The SPIRIT project has also formed a partnership with the 4-H Robotics and GIS/GPS Project (NSF ITEST #0833403) in which the robots eventually to be used in that project for 4-H distribution will be CEENBoTs.

To meet teacher educational robotics needs, specific educational market responses with benchmarking will be further developed. Middle school, high school and community college success will be determined by engagement in integrated STEM learning as evidenced by pilot testing and field-testing at all levels. Evidence at the university level will include student interest in engineering disciplines and as measuring increases in student retention and numbers of graduates. After-school program success will be examined with student enrollment numbers, student interest perceptions and ongoing participation in further programs. Finally, hobbyists that might work with a young person at home will be interviewed, targeting a platform that is customizable, competition-quality, and fun for building in that setting. Success in both after-school and home settings will also be examined by youth focus groups and the numbers of kits distributed, while targeting better youth STEM experiences in these settings. As of December 2011, estimations of the long-term distribution of the CEENBoT include the following.

Estimated Educational Market Size and Yearly CEENBoT Sales Potential (as of December 2011)

| Educational Market | Estimated Market Size | Yearly Unit Sales Potential |
|--|-----------------------|-----------------------------|
| U.S. Middle Schools ¹ | 27,000 Schools | 5 per School |
| U.S. High Schools ¹ | 30,000 Schools | 5 per School |
| U.S. Electronics and Computer Engineering Colleges | 500 Colleges | 100 ECE students / College |
| U.S. Community Colleges ² | 1,065 Colleges | 30 Tech students / School |
| After-school Programs | 5,000 Programs | 5 per Program |
| Hobbyist Market ³ | 25,700 Hobbyists | 25,700 Hobbyists |
| Total Market Potential | | 417,650 Units |

¹publicschoolreview.com; ²nces.ed.gov/programs/coe/2008/analysis/sa04.asp

³ibisworld.com/industry/retail.aspx?indid=1080&chid=1

Estimated CEENBoT market penetration within 5 Years of Full Production in 2013

| Educational Market | Penetration Percentage | Anticipated Yearly Sales |
|---|------------------------|--------------------------|
| U.S. Middle Schools | 1% | 1,300 Units |
| U.S. High Schools | 0.5% | 700 Units |
| U.S. Electronics and Computer Engineering Colleges | 1% | 700 Units |
| U.S. Community Colleges / Trade Schools | 0.3% | 100 Units |
| After-school Programs | 1.6% | 400 Units |
| Hobbyist Market | 2% | 400 Units |
| Est. Market Potential | 0.9% Composite | 3,600 Units |
| Est. Annual Sales @ \$200/Unit (3,600 total) + \$50/module (9,300 total) | | \$1,185,000 |

Some significant barriers to educational market expansion of course exist, and we are considering these barriers. These barriers include: minimal awareness of the CEENBoT; strong competition (sales channels, existing orders, strategic relationships, established distribution chains, use through sponsored competitions); limited school budgets with small allowances for new products; and, complicated sales processes and long sales cycles.

In addition to the CEENBoT, the SPIRIT project's efforts at market research has indicated that there are currently five other major common educational robotic platforms which are already available and which are currently available for comparison purposes: TekBot, VEX, Scribbler, LEGO and Boe-Bot. Three of these platforms are suitable for a younger middle school audience, but do not provide a high level of programming capability (VEX, LEGO and Scribbler). These platforms instead provide a very limited icon driven programming environment. They also do not provide electronics design experiences or software design within the educational setting of typical school environments. The TekBot and Boe-Bot provide some programming capabilities in terms of relevant hardware and software experiences. However, the Boe-Bot comes already preassembled in some form with no soldering or electronics work. The TekBot comes closest to the CEENBoT in its capabilities of C programming, sensor additions, soldering and construction, and platform modifications, but is relatively fragile for middle school and high school students.

Market Research Identified Key Competitors to the CEENBoT in Educational Robotics

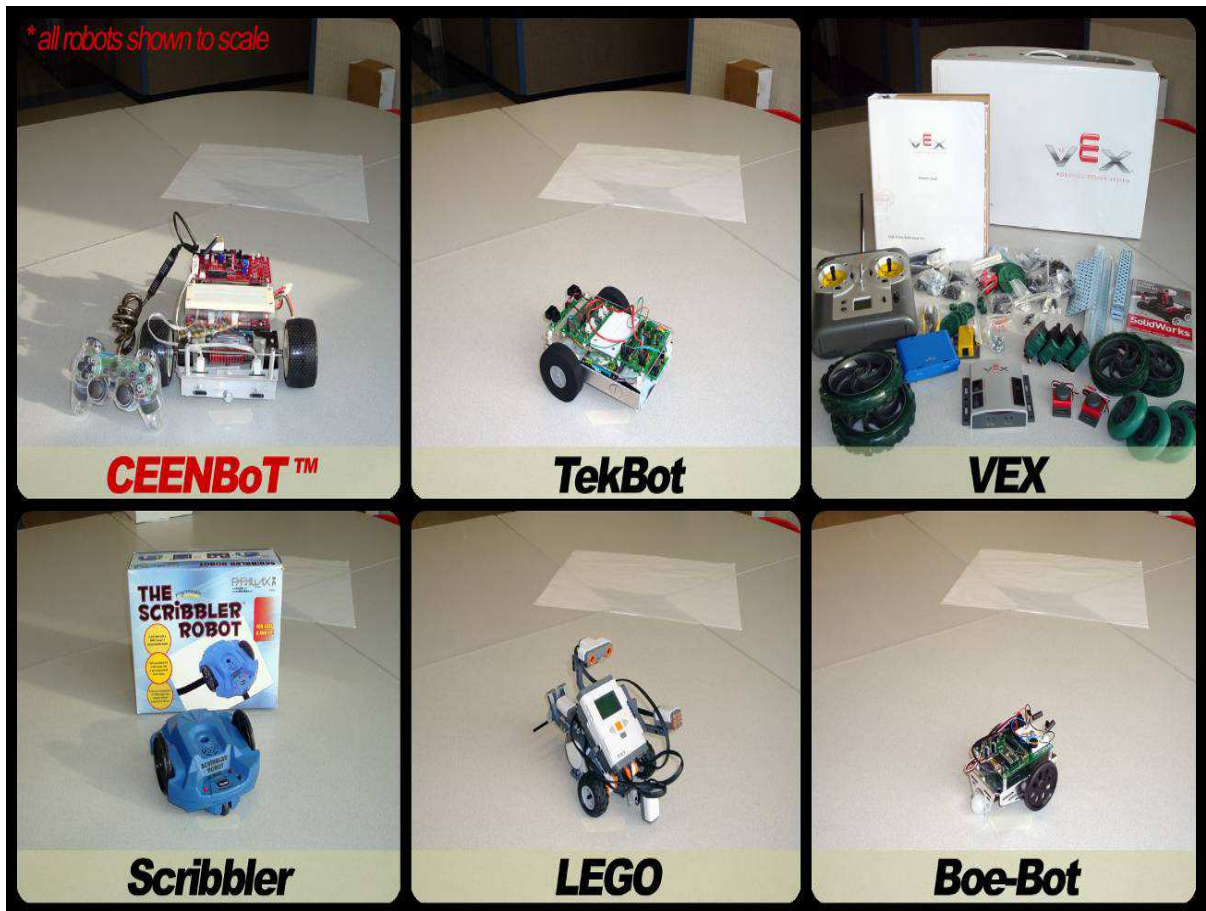

Also, extending the TekBot platform beyond introductory courses would be very challenging to schools due to a small prototyping area for electronics circuits, a less than precise drive motor system, the lack of a quick connect battery system and in general, the somewhat flimsy superstructure.

A poor superstructure (as found in our initial SPIRIT use) is particularly problematic for educators, since robotics in elementary, middle school, and high school classrooms get bounced around and roughly handled by students quite frequently. A comparison of these educational robotic platforms with the CEENBoT is shown on the next page in a comparison chart.

| Advantages of the SPIRIT CEENBoT Educational Robotics Platform as of December 2011 | | | | | | |
|--|-------------|---------------|---------------|---------------|--------------------|---------------|
| Feature | CEENBoT | LEGO | TekBot | Boe-Bot | Scribbler | VEX |
| Capacity for self-design hardware modifications | Very High | None | High | Medium | Low | High |
| Can be used in ECE course sequences including upper division? | Yes | No | Yes (limited) | No | No | No |
| Microprocessor Design and Programming? | Yes | No | Yes | Yes | Limited (K-8 only) | No |
| Graphical programming interface (multiple languages)? | Yes | No (GUI only) | Yes | No | No (GUI only) | No (GUI only) |
| Capacity for additional sensors (e.g., GPS, video, Wi-Fi)? | Yes | No | Yes (limited) | Yes (limited) | No | Yes (limited) |
| Parts from readily available sources? (e.g., RadioShack) | Yes | No | Yes | Yes | No | Yes |
| Low cost for basic unit? (<\$250) | Yes (\$175) | No | Yes (<\$120) | Yes (<\$160) | Yes | Yes |
| Outdoor robustness? | Yes | No | No | No | Yes (limited) | No |
| Soldering skills, circuit design, and electronics design? | Yes | No | Yes | No | No | No |
| Capacity for middle-high school classrooms / clubs / after school? | Yes | Yes (limited) | Yes | Yes | No | Yes |
| Maps to K-12 STEM Disciplines with cyberinfrastructure? | Yes | No (K-8 only) | No | No | No (K-8 only) | No |

Thus, our educational market research as of 2011 has shown that for the successful distribution of the CEENBoT to schools, we must be able to satisfy five key attributes: 1) to efficiently manufacture, market, and distribute CEENBoT robots, 2) to build and strengthen relationships with strategic customers and educational partners, 3) to cut costs and strengthen financial positions, 4) to build and strengthen distribution channels with schools, and 5) to improve and adapt the CEENBoT and the SPIRIT cyberinfrastructure to meet educator needs.

SPIRIT Lesson Results to Date:

The SPIRIT 2.0 effort has continued efforts where trained teachers develop lessons for their classrooms. These developed lessons are then further refined for possible use in the curriculum. As of December 2011, a total of more than 260 fully completed AEIOU Lessons, representing all four STEM areas have been developed, edited, and posted to the SPIRIT website. Nearly 150 other lessons are in various stages of lesson development, editing, and

refinement. The posted lessons are interdisciplinary and involve interrelated STEM concepts, as consistent with educational robotics. The lesson writers have diligently went through many rough and previously drafted lesson ideas and found “the best of the best”. Additional writing efforts have also concentrated on the instructional component (I) of the modular lessons to be sure the concept instructional base has been well developed. Along side of the full curriculum lessons, 20 games to explore CEENBoT movements have also been created, edited and posted. The percent of the 260 lessons currently available to teachers piloting or field-testing the lessons include: Science – 43.7%, Technology – 12.4%, Engineering – 9.2%, and Mathematics – 34.6%. The writing of mathematics lessons has been particularly emphasized, with a special focus on introductory algebra. All lessons can be viewed under their primary STEM headings at the SPIRIT lesson website of:

<http://www.ceen.unomaha.edu/TekBots/SPIRIT2/>

This website also includes a variety of password protected draft lessons, in various stages of development, under the Science, Technology, Engineering, and Mathematics, as well as construction tutorial links, classroom resources, student assessments,

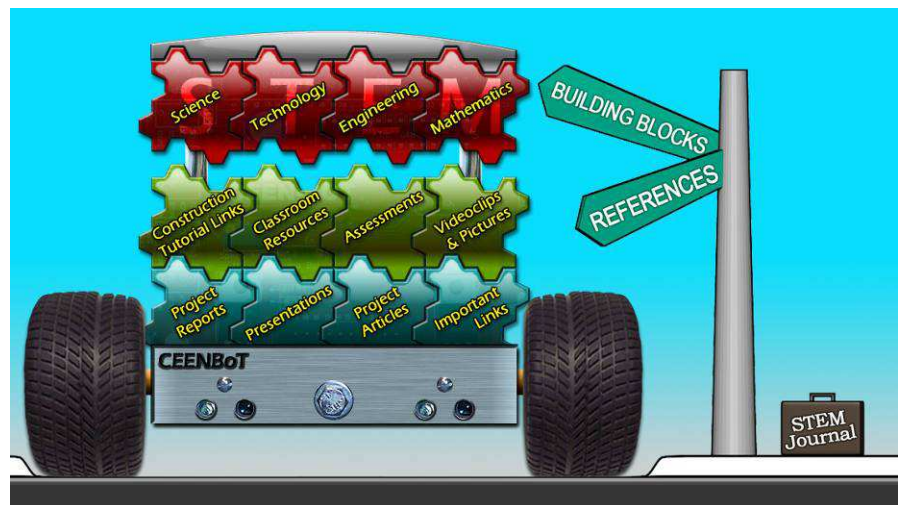

videoclips and pictures, project reports, presentations, project articles, robot cartoons, and important links. These sections of the website will all be further populated as the SPIRIT curriculum continues to grow and evolve.

Cyberinfrastructure Results to Date

The SPIRIT lesson delivery system continues to evolve in ways that support the teacher lesson development and usage. To date, the cyberinfrastructure includes a working database structure, lesson query methods, and lesson uploading and tagging tools. The increased number of lessons and lesson tags has motivated a few enhancements to the user interface as well as ways to clear all tag selections, search all tags, and view search results by pages. The cyberinfrastructure prototype is now able to handle thousands of lessons with tag counts that are typically two orders of magnitude higher in ways that are efficient and intuitive, making for a more effective educator experience in locating SPIRIT lessons.

As described previously, SPIRIT instructional components are divided into five categories: Asking, Exploring, Instructing, Organizing, and Understanding (AEIOU).

Component categories are stored individually as files and are accessed through a system of hierarchical tagging. An online database stores category and tagging information that is displayed under the "Select" tab. The teacher first opens a tag category under the "Select" tab such as Robot Capability, Grade Level, or Science, Technology, Engineering, or Mathematics (STEM)

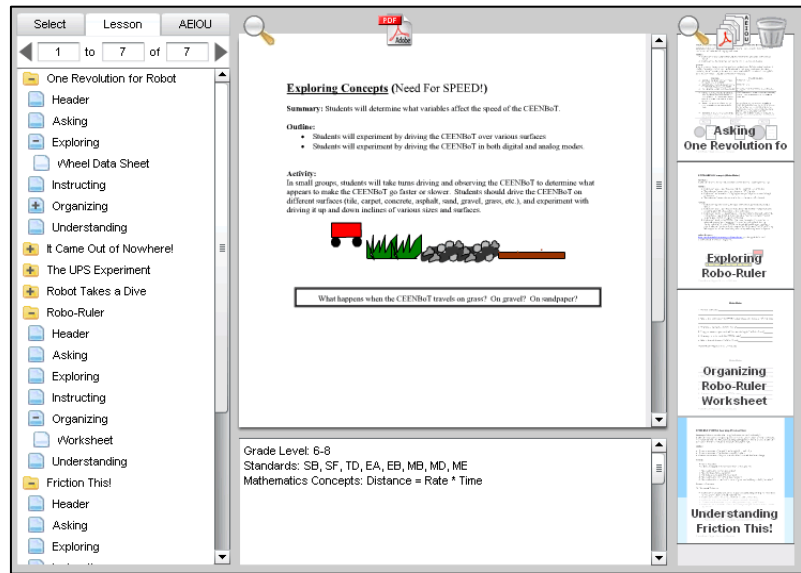

Concepts or Standards, and makes selections within the tag categories. The teacher can then view component information based upon the originating "Lesson" or based upon the "AEIOU" component type using the associated tabs.

Under the Lesson tab, folder icons are displayed for each originating lesson grouping. The lesson folders can be opened to show the lesson components and resources. The large center window displays the associated page when the user clicks on a lesson component or resource. The text area below the center pane displays the standards-based tag information for the component. The teacher user can then drag and drop the displayed item from the center window to the far right window to mix-and-match lesson components and resources, and thus create a customized lesson grouping which can be printed as output in a Portable Document Format (PDF) file by clicking the lesson group PDF icon at the top of the far right pane.

Recent developments in the SPIRIT project have also implemented more efficient protocols for managing the expanding number of lessons in the database. The database structure

and query commands have been developed to optimize the time for search and selection. The entry of lessons permits that the AEIOU components be split into separate files and individually tagged which can be very labor intensive. A spreadsheet support tool was developed where the lesson information is entered, then

| A | B | C | D | E | F | G | H | I | |
|-----|---|--|------------------------|--------|-------|-------|----------|--|----------------------------------|
| 5 | Tag Categories | Tag Selection | | | | | | Add It! | |
| 6 | Grade Level | S-B: Mode | | | | | | Fill in this, just tag with category st | |
| 7 | Robot Capability | | | | | | | The concept tag is added automatic | |
| 8 | Science Concepts | Friction | | | | | | Add tags one l at a time and update | |
| 9 | Science Standards | SA: Scien | SB: Physical Science | | | | | After update, then update lookup te | |
| 10 | Technology Concepts | | | | | | | Add Lessons | |
| 11 | Technology Standards | | | | | | | Add lessons one at a time, write to | |
| 12 | Engineering Concepts | Applied Physics | | | | | | Select all tags needed | |
| 13 | Engineering Standards | EC: Nature of E | | | | | | Tags applied to group and anou | |
| 14 | Mathematics Concepts | EC: Communi | | | | | | Two-Fs: Use two concept tags | |
| 15 | Mathematics Standards | ES: Scien | | | | | | Two-Fs: Add grp2 tag to second l | |
| 16 | | | | | | | | | |
| 17 | | Execute BAT Done | | | | Y | | << Write DB Done | |
| 18 | 0 << Add files OutRow (if zero, clean) | Execute build bat file | | | | | | Write to Database Spreadsheets | |
| 19 | 83 << Add file OutRow (if zero, clean) | | | | | | | | |
| 20 | Used for next add or for spreadsheet update | | | | | | | | |
| 21 | | N | << Auto Execute? (Y/N) | | | | N | << Auto Write? (Y/N) | |
| 22 | | | | | | | | | |
| 23 | C:\p02sw\ << Path to path.exe (check for) | | | | | | | Create Database Commands | |
| 24 | 457 << Start Row | Create File Commands | | | | | | | |
| 25 | 457 << End Row | | | | | | | | |
| 26 | | | | | | | | | |
| 27 | Source Path | Source DOC file name | STEM | Folder | Group | AEIOU | Resource | rHid Laid Instructing Tag Name HAEIOU Title | |
| 413 | C:\p02sw\p02sw\413-000911 | 3026_Incredible Bread Chip_Circuit.doc | S | | 11 | 36 | 11 | 11 | 10 Incredible Bread Chip Circuit |
| 414 | C:\p02sw\p02sw\413-000911 | 3029_Power_Up_Your Breadboard.doc | S | | 11 | 38 | 11 | 11 | 410 Power Up Your Breadboard |
| 415 | C:\p02sw\p02sw\413-000911 | 3035_HookItUp-Proless_the_compress.doc | S | | 11 | 45 | 11 | 11 | 3 Proless The Compress |

spreadsheet macro programs create the file manipulation and renaming commands. The spreadsheet tool also provides for the entry of tag information and creates the database commands for lesson grouping and tagging. The spreadsheet tool has been an efficient way to prototype the process of lesson entry into the server file system and database.

A navigation bar was also created under the "Select" tab to help teachers locate and choose among the increased number of tag categories and tags. Teachers can open or close all tag categories, clear all selections and can do contextual searching for lesson tags. A navigation bar was also added to the "Lesson" and "AEIOU" tabs which displays the lessons in pages showing the first and last lesson number on the page and the total number of lessons based on the chosen tag selection.

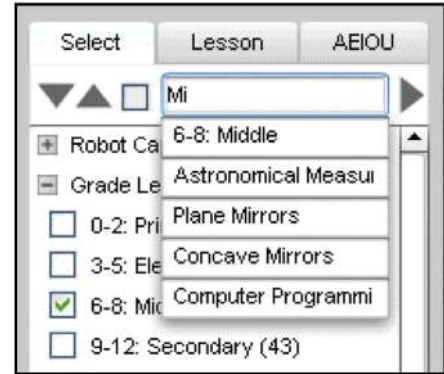

The SPIRIT cyberinfrastructure prototype thus provides a means for the educator to locate lesson components and resources using transparent filtering and intuitive interactions. As the number of lessons has increased, the user interface has been extended in ways that maintain a simple user interaction model. The database structure and query commands were also redesigned to quickly return results.

The SPIRIT cyberinfrastructure prototype can be viewed at: <http://spirit.unomaha.edu>

The educators that have started using the cyberinfrastructure prototype have made some initial comments on database feedback forms and in person, indicating a need for a tutorial on basic usage and operation. In response, a help button was also added that links to an animated demonstration of how to search and view lesson components and build custom lessons. The SPIRIT project is continuing to routinely get feedback from users to refine the cyberinfrastructure operations.



Extensions to the cyberinfrastructure database being addressed include grouping lessons by word frequency analysis, usage statistics, and user evaluation. All extensions could be used in developing alternative lesson search methods that could use software suggestions to teachers rather than topic selection. Word frequency analysis involves pre-scanning the lessons and recording in the database all words with a relatively low frequency and which lessons contain those words. The word list could be used as an alternative or extended set of tags for lesson selection. Usage statistics could involve recording the clicks and drags of how the cyberinfrastructure is being used and which tags and lessons are being selected and what components are being included in custom lessons. User lesson evaluation could also collect user ratings for each lesson component through an evaluation form. The usage statistics and educator evaluations could be used to rank the lessons by instructional popularity which could be added to the lesson search options so that the most popular lessons could be located for educator use and less popular lessons could be reviewed, edited, or perhaps eventually removed. Our cyberinfrastructure team is now considering these potential enhancements.

A further area in development of the SPIRIT cyberinfrastructure centers on the teacher evaluation and implementation of lessons in the database. While searching, reading, and selecting lessons, a teacher will be able to post an evaluation or comment on the entire lesson or an individual lesson component. When a teacher uses a lesson in their classroom they can also return to the cyberinfrastructure interface to rate or comment on the lesson. The lesson author or editor can review the ratings and comments and make changes and updates to the lesson or the database.

When first viewing a lesson or component, only the top line of the rating form is visible which shows the number of responses and the average rating in filled stars. Clicking on the comment icon (plus sign) will then reveal the entire form along with the lesson that allows the teacher to rate the lesson.

[Click here to rate or comment](#) Responses: 1 Current Rating: ★★★★★

ASKING Questions (Solutions, Solutions, Could it Be?)

Summary:
The concept of what is a solution and the concept of how many solutions are possible for a linear system will be explored.

The data collected on the form includes an overall rating of the lesson, a comment about the lesson, and the number of students that have worked with the lesson by grade level. The rating information is added to the overall average rating and appropriate comments may be added to the lesson display after the lesson author or editor has reviewed the comments. The numbers of students that have interacted with the lesson can also serve as additional lesson evaluation information. A "CAPTCHA" word and an e-mail address must be entered to send the form. The "CAPTCHA" word will help secure the form from automated attacks and the e-mail address will help define the uniqueness of the respondent and give some indication about the number of respondents.

[Click here to rate or comment](#) Responses: 1 Current Rating: ★★★★★

| Rating | Teaching | | | | | | | | | | | | | | | | | | |
|---|--|---------------|--------------------|---------------|-----|----------------------|---|-----|----------------------|---|-----|----------------------|---|------|----------------------|---|-------|----------------------|---|
| How would you rate this lesson? Low <input type="text"/> High | To whom have you taught this lesson? | | | | | | | | | | | | | | | | | | |
| Responding Would you like to send a comment? <input type="text"/> | <table border="1" style="width: 100%; border-collapse: collapse;"> <thead> <tr> <th>Grade Level</th> <th>Number of Students</th> <th>Lesson Totals</th> </tr> </thead> <tbody> <tr> <td>K-2</td> <td><input type="text"/></td> <td>0</td> </tr> <tr> <td>3-5</td> <td><input type="text"/></td> <td>0</td> </tr> <tr> <td>6-8</td> <td><input type="text"/></td> <td>0</td> </tr> <tr> <td>9-12</td> <td><input type="text"/></td> <td>0</td> </tr> <tr> <td>Other</td> <td><input type="text"/></td> <td>0</td> </tr> </tbody> </table> | Grade Level | Number of Students | Lesson Totals | K-2 | <input type="text"/> | 0 | 3-5 | <input type="text"/> | 0 | 6-8 | <input type="text"/> | 0 | 9-12 | <input type="text"/> | 0 | Other | <input type="text"/> | 0 |
| Grade Level | Number of Students | Lesson Totals | | | | | | | | | | | | | | | | | |
| K-2 | <input type="text"/> | 0 | | | | | | | | | | | | | | | | | |
| 3-5 | <input type="text"/> | 0 | | | | | | | | | | | | | | | | | |
| 6-8 | <input type="text"/> | 0 | | | | | | | | | | | | | | | | | |
| 9-12 | <input type="text"/> | 0 | | | | | | | | | | | | | | | | | |
| Other | <input type="text"/> | 0 | | | | | | | | | | | | | | | | | |
| Sending Type the word shown below and enter your e-mail address, then click the Send button. Your e-mail address will only be used to determine uniqueness and for statistical analysis. | | | | | | | | | | | | | | | | | | | |
|  | | | | | | | | | | | | | | | | | | | |
| Word: <input type="text"/> E-mail: <input type="text"/> | | | | | | | | | | | | | | | | | | | |
| <input type="button" value="Send"/> | | | | | | | | | | | | | | | | | | | |

ASKING Questions (Solutions, Solutions, Could it Be?)

Summary:
The concept of what is a solution and the concept of how many solutions are possible for a linear system will be explored.

The cyberinfrastructure stores the form data in the database along with the other lesson search criteria allowing the collected data to assist in lesson display and selection. Database search results can be modified based on the evaluation data so that the most popular lessons are displayed first, for example. Other types of lesson suggestions will include all lessons highly rated by an individual respondent or other lessons in the same subject or content category used by an individual teacher respondent. The appropriate comments that are included with the lesson display will also support the refinement and further development of the lessons and concepts in the classroom environment.

During Year 3 of the SPIRIT 2.0 efforts, the cyberinfrastructure development focused on the educator experience beyond lesson search and retrieval. Features that have been added or are in the development stages include an enhanced help video, enhanced lesson ratings and comments, improved context tags, and more secure user login using Google, Facebook, Yahoo, or OpenID. The AEIOU lesson format has also been adopted by the NSF ATE Project SHINE Project (NSF# 0903157) who decided to also share their lessons through our SPIRIT database system, creating the need to add category tags that allow educators to search for lessons based on a wider project context, that includes robotics, mechatronics, industrial robotics, and energy-related tags. Project SHINE lessons provide some nice extensions of robotics into the

workplace that are seamlessly integrated with the robotics lessons from SPIRIT in the overall SPIRIT database. Lesson ratings and comments integrated into the SPIRIT database provides a way for educators using the overall set of SPIRIT (and SHINE) database of lessons to evaluate and share their experiences with the lessons. Also, incorporating a login method that uses existing social network or cloud computing accounts will make using the lesson rating and evaluation process easier for the educator.

As described earlier, the cyberinfrastructure database stores category and tagging information that is displayed under the "Select" tab. The educator first opens a tag category under the "Select" tab and makes selections, then views component information by selecting the "Lesson" or "AEIOU" tabs. Under the Lesson tab, folder icons are displayed for each originating lesson grouping. The lesson folders can be opened to show the lesson components and resources. The large center window displays the associated page when the user clicks on a lesson component or resource. The text area below the center pane displays the standards-based tag information for the component. The educator can then drag and drop the displayed item from the center window to the far right window to mix-and-match lesson components and resources, and thus create a customized lesson grouping which can be printed as output in a Portable Document Format (PDF) file by clicking the lesson group PDF icon at the top of the far right pane.

As diverse robotics-related STEM lessons are added to the cyberinfrastructure from SPIRIT and other National Science Foundation projects (such as SHINE), new context tags will allow educators to select educational robotics consistent lessons based on slightly wider topics such as energy, and industry applications. Educators in regional workshops and industry mentored workshops have developed lessons using the AEIOU format that are typically framed in a STEM context, and use the instructional components (the I in AEIOU) developed for the SPIRIT robotics lessons. Expanding the lesson context demonstrates the flexibility of the lesson database design and the AEIOU lesson format. The robotics curriculum touch points contained in the instructing components also serve as the touch points for the STEM areas such as energy, electronics, industrial robotics and mechatronics in the industry mentored lessons.

Using the SPIRIT cyberinfrastructure to select lessons is in essence, similar to an online shopping experience as educators search for lessons and lesson components. Educators have become accustomed to ratings and comments being attached to products and content that they view online. To enhance the social interaction with the SPIRIT cyberinfrastructure, the rating and comment form mentioned earlier follows this typical format, as seen on commercial websites.

The ratings and evaluation form includes options to rate the lesson component on a five point scale with the results being displayed using the five stars in the heading line. Educators can also respond with comments and post the number of students that have experienced the lesson component. Other even simpler methods of rating are being considered such as a "I Like This" or "Thumbs Up" button where the educator would just click a button to indicate they prefer this type of lesson. When preferences toward lessons are collected over many different educators, the better lessons emerge as the ones with more selections.

The enhanced authentication method will allow the cyberinfrastructure to keep track of the lessons that the educator has viewed, which lessons they prefer, and predict which lesson they might prefer based on the preferences of others. Educators will be able to return to lessons they have viewed to rate and comment on the lessons. The authentication component of the cyberinfrastructure is still in the testing and development stages.

To make the lesson evaluation experience simpler and more efficient for the educator, different login methods have also been explored and undertaken. Many new technologies have been developed in recent years that allow users to authenticate using their existing social networking accounts rather than having to create and remember yet another website account.

The authentication method being tested this last year in SPIRIT uses the OpenID standard that redirects the educator to their selected account provider.

As mentioned, the SPIRIT cyberinfrastructure prototype can be viewed at:

<http://spirit.unomaha.edu>



Cyberinfrastructure Mobile Computing Revisions

Further Cyberinfrastructure development work during 2011 on the existing SPIRIT 2.0 cyberinfrastructure has evolved to focus more on enhancing existing features and content updates than on expanding features. Moving the focus way from adding features is due in part to changes in the user access platforms. With more content being delivered to mobile, tablet, and pad devices, the current

static layout and scripting methods needed updating. To address these mobile computing issues, future cyberinfrastructure development will begin to explore new techniques that provide support for all types of devices, legacy and emerging, while also supporting the same interactive experience as the current lesson delivery system.

Updating and expanding content within the cyberinfrastructure has

involved editing and updating the science instruction components, adding standardized assessments to the mathematics and science instruction components, and adding additional lessons for robotics and industry applications. The science instruction components were reviewed by a master science teacher, more detailed explanations were provided, and pictures and diagrams were attached. The updated instruction components were added to the lesson files and included in the lesson database. In addition to instructional component updates, publicly

available standardized test questions from many different national sources were reviewed and questions were selected that were specific to the mathematics and science instruction components in the cyberinfrastructure. Sample standardized question files were prepared for various instruction components and added to the database as attachments to the instructional components. The standardized question attachments are included in the lesson display anytime a lesson with the associated instructional component is selected from the database. As is the case each year, new lessons and instructional components were added to the database in the contexts of robotics and industry applications. The current lesson counts sorted by the selection tag categories are shown at the end of this section. Many of the lessons are tagged with multiple categories so the category count subtotals will not add up to the lesson count total, except for the Context tags of Energy, Industry, and Solar where that tagging has been disjoint.

Changes to the database structure and to the methods used to edit and track lessons have attempted to improve the efficiency of lesson delivery and development. The lesson file names in the file system structure were changed to make the names more standardized and readable. This was done to so that static browse-able pages could be generated and delivered from the database and so that files that are downloaded from the database have standardized names. Some of the methods and functions that would be needed to deliver static pages from the database were explored, but currently the delivery of static pages from the database has not been implemented.

One other area of development and exploration involved the tracking of lessons as they are being written and edited. As the teachers and other writers create lessons, the editing team of master teachers reviews the lessons, and the website and

| File Name (Index # to be added) | Lesson topic | STEM Index # | Date Recv'd | Who Recv'd Editor 1 | Date sent | Date for pc |
|--|----------------------|--------------|-------------|---------------------|-----------|------------------------|
| I_Sci_057_Organic Chemistry Nomenclature | | | 8/15 | Steve H | | |
| I_Sci_058_Natural Resources.doc | | | 8/15 | Steve H | | |
| I_Sci_059_Photosvoltaic Cells.doc | | | 8/15 | Steve H | | |
| I_Sci_060_Acceleration.doc | | | 8/15 | Steve H | | |
| I_Sci_061_Enzymes.doc | | | 8/15 | Steve H | | |
| I_Tech_017_Economics.doc | | | 7/15 | steve h | | |
| I-Math-07-Real.doc | updated real numbers | | 8/20 | Steve H | | |
| I-Sci-31-Circular_Motion.doc | | updated | 7/19 | steve | | |
| M082-Map_Making1.doc | cartography | | | | | |
| M083-Map_Making2.doc | cartography | | | | | |
| M084_SHINE_Measurement_in_Manuf.doc | dimensional analysis | | 6/15 | Lynn | | 6/22-L sent tr |
| M085_SHINE_Defining_the_curve.doc | central tendency | | 6/15 | Lynn | | 6/22-L sent tr |
| M086_SHINE_Em-Brace_It.doc | pythagorean theorem | | 6/19 | Lynn | | 6/22-L sent tr, 8/1-Ly |

database team post the lessons, this work has continued to be tracked in a shared spreadsheet within Google Documents. This is a simple and direct approach that has worked very well, but recently Google Documents introduced scripting which could be used to further automate lesson document tracking. The lesson tracking spreadsheet was reviewed and improved, but scripting seemed to make things more complicated than needed, so the automation idea was not developed further. The methods and ideas developed and explored related to the static web pages and the lesson tracking spreadsheet, although not used in the current version of the cyberinfrastructure, will be applied in the next version designed to support mobile, tablet, and pad devices, which is discussed next.

One of the most significant changes in electronic content delivery over the last few years involves the explosion of mobile, tablet, and pad devices. Even during just the last couple years, the need to develop a mobile friendly version of the cyberinfrastructure has become more apparent. The current mobile platforms use different development environments which would seem to require individual applications to support each device. Another approach however uses new features currently implemented in the new browsers found on current mobile and pad devices.

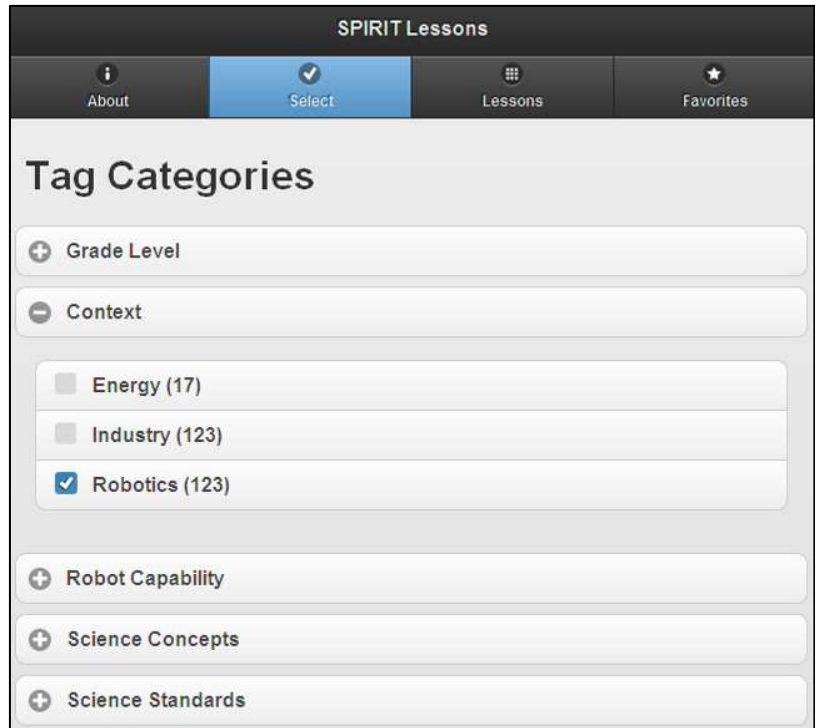

This approach uses the web browser to view webpages that are scripted to provide the look and feel of a native application. With this approach one scripted website can provide native application type access to the current lesson database. Using this scripted website approach will be the basis for further development of the cyberinfrastructure since it uses open source standards, provides access for multiple devices, and will provide support for additional devices that currently do not have access to the lesson database. The original cyberinfrastructure is located at spirit.unomaha.edu and the new mobile version under development is located at spirit.unomaha.edu/m.

SPIRIT 2.0 Cyberinfrastructure Lesson Tags

As of December 2011, lessons in the SPIRIT 2.0 cyberinfrastructure are tagged in the database by the context, grade level, STEM standards, and main STEM instructional component. The context is the only tag group that is currently disjoint, so it is the only grouping that will add up to the total number of lessons. Other tags were applied as needed to the lessons. The lesson tags are listed below along with the number of lessons that are associated with that lesson tag.

| SPIRIT 2.0 Cyberinfrastructure | Lessons |
|--------------------------------|---------|
| All lessons | 263 |

| Context | Lessons |
|----------|---------|
| Energy | 17 |
| Industry | 123 |
| Robotics | 123 |

| Grade Level | Lessons |
|--------------------|----------------|
| 0-2: Primary | 5 |
| 3-5: Elementary | 39 |
| 6-8: Middle | 167 |
| 9-12: Secondary | 132 |

| Science Standards | Lessons |
|----------------------------|----------------|
| SA: Science as Inquiry | 124 |
| SB: Physical Science | 101 |
| SC: Life Science | 16 |
| SD: Earth and Space | 16 |
| SE: Science and Technology | 89 |
| SF: Science Perspectives | 47 |
| SG: Nature of Science | 8 |

| Science Instruction Components | Lessons |
|---------------------------------------|----------------|
| Acceleration | 1 |
| Astronomical Measurement | 2 |
| Cell Organelles | 2 |
| Circular Motion | 1 |
| Community Ecology | 2 |
| Density | 2 |
| Dimensional Analysis | 2 |
| Electric Current | 3 |
| Electrical Power Consumption | 1 |
| Elements | 1 |
| Energy and Energy Transfer | 6 |
| Force | 1 |
| Friction | 7 |
| Friction on an Incline | 1 |
| Heredity | 1 |
| Hooke's Law | 1 |
| Infrared | 2 |
| Living vs. Nonliving | 1 |
| Magnetism | 3 |
| Measurement | 8 |
| Mechanical Advantage | 1 |
| Microbes | 3 |
| Mixtures | 2 |
| Newton's 1st | 2 |
| Newton's 2nd | 3 |
| Newton's 3rd | 2 |
| Ohm's Law | 5 |
| Osmosis and Tonicity | 1 |
| Photovoltaic Cells | 1 |
| Physical and Chemical Properties | 1 |

| | |
|------------------------|---|
| Plane Mirrors | 3 |
| Planetary Motion | 1 |
| Plate Tectonics | 4 |
| Population Ecology | 1 |
| Power | 1 |
| Power Grid | 1 |
| Radioactive Decay | 1 |
| Solar Collector Basics | 2 |
| Solar Home Design | 1 |
| Solar System | 2 |
| Solubility | 2 |
| Terrestrial Seasons | 1 |
| Thermodynamics | 1 |
| Titration | 1 |
| Torque | 1 |
| Viscosity | 1 |
| Voltage | 1 |
| Waves | 1 |
| Work | 1 |

| Technology Standards | Lessons |
|-----------------------------|----------------|
| TA: Creativity, Innovation | 125 |
| TB: Collaboration | 82 |
| TC: Information Fluency | 94 |
| TD: Critical Thinking | 105 |
| TE: Digital Citizenship | 16 |
| TF: Technology Operations | 59 |

| Technology Instruction Components | Lessons |
|--|----------------|
| Communications | 5 |
| Computer Programming | 4 |
| Creativity | 1 |
| Critical Thinking | 4 |
| Data Analysis | 10 |
| Economics | 1 |
| Information Literacy | 4 |
| Leadership | 1 |
| Positional Number Systems | 1 |
| Problem Solving | 12 |
| Scientific Inquiry | 9 |
| Team Building | 1 |
| Technical Writing | 4 |

| Engineering Standards | Lessons |
|------------------------------|----------------|
| EA: Design | 72 |
| EB: Connections | 122 |
| EC: Nature of Engineering | 26 |
| ED: Communication | 64 |

| | |
|-------------|----|
| EE: Society | 24 |
|-------------|----|

| Engineering Instruction Components | Lessons |
|---|----------------|
| Applied Physics | 1 |
| Engineering Design | 10 |
| Error Analysis | 1 |
| Intellectual Property | 1 |
| Invention vs Innovation | 3 |
| Laser Engraving | 1 |
| Scale Drawings | 3 |
| Shop Safety | 1 |
| Simple Machines | 1 |
| Technological Systems | 1 |
| Welding | 1 |

| Mathematics Standards | Lessons |
|-----------------------------------|----------------|
| MA: Numbers, Operations | 83 |
| MB: Functions, Algebra | 65 |
| MC: Geometry, Spatial Sense | 72 |
| MD: Measurement | 128 |
| ME: Data, Statistics, Probability | 110 |

| Mathematics Instruction Components | Lessons |
|---|----------------|
| Area of Polygons | 5 |
| Best-Fit Curves | 7 |
| Cartography | 3 |
| Central Tendency | 6 |
| Circles | 4 |
| Compound Inequalities | 0 |
| Derivative | 1 |
| Direct Variation | 1 |
| Displays of Data | 4 |
| Distance = Rate * Time | 10 |
| Distance Optimization | 1 |
| Exponential Functions | 1 |
| First Fundamental Theorem of Calculus | 1 |
| Functions | 2 |
| Geometry Vocabulary | 1 |
| Inverse Variation | 2 |
| Linear Functions | 3 |
| Linear Systems | 1 |
| Negative Exponents | 1 |
| Perimeter | 1 |
| Probability | 1 |
| Proportions | 1 |
| Pythagorean Theorem | 3 |

| | |
|-------------------------|---|
| Quadratic Functions | 1 |
| Ratios and Proportions | 5 |
| Real Numbers | 3 |
| Rectangular Coordinates | 2 |
| Related Rates | 1 |
| Riemann Sum | 1 |
| Scientific Notation | 1 |
| Signed Numbers | 3 |
| Slope | 3 |
| Surface Area and Volume | 7 |
| Trig Functions | 2 |
| Two Step Equations | 1 |



Construction Tutorial Development Results:

As of December of 2011, there continues to be significant and consistent progress on robot construction tutorials throughout the SPIRIT project to support the use of the CEENBoT in the classroom. These tutorials continue to be updated frequently, and are found on the general website by clicking on the prominent CEENBoT tutorial banner (<http://www.ceen.unomaha.edu/TekBots/SPIRIT2/Tutorials/>) where materials are accessible.



The construction tutorials are divided into modules corresponding to the different circuit boards in the robot and the assembly of all the pieces into the CEENBoT. Each module takes about one to four hours to complete depending on the experience of the student.

The instructions have evolved from a narrative description of how to assemble the parts to an interactive Flash presentation where each step is described on an individual slide. Narrative is kept to a minimum and embedded video clips and clickable assistance is provided. Parts for each board are identified separately. The first step of each module is to place the parts onto a “parts map.” This helps ensure that the components are placed correctly. The interactive instructions guide the educator or student through the placement of each component. The steps are listed in a table on the left side of the screen. This ensures that none of the steps are omitted and that the correct sequence is used. The main part of the instruction shows the part as it is seen on the parts map with a short description of what needs to be done. Many of the steps include a link to a video-clip to help with specific constructions.

 A screenshot of a web-based tutorial interface for the CEENBoT 324 Circuit Board. The interface has a red border and a white background. At the top left, the CEENBoT logo is displayed in red and black, followed by the text "Tutorial: 324 Circuit Board (324 board only)". Below this is a "Navigation" sidebar with a list of steps:

- i. Populated (top)
- ii. Populated (bottom)
- iii. Preloaded parts
- iv. ** Read before constructing
- 1. SPST Switches S1, S3, S4, S5
- 2. Red LED D2
- 3. Green LEDs D3, D5
- 4. 3-pin male header
- 5. 3-pin male headers (5)
- 6. Male latched connectors (4)
- 7. 20-pin male connector
- 8. Speaker
- 9. DB9 male connector
- 10. DB9 female connectors (2)
- 11. Final Check

 The main content area shows a "Top View - Populated" of the red circuit board. The board is populated with various components, including a central microcontroller, several capacitors, and connectors. A blue ribbon cable is plugged into a connector on the left. The board is labeled "CEENBoT 324 U2.21". At the bottom left of the interface, it says "rev: 2010.03.30 Copyright © 2010 University of Nebraska Board of Regents". At the bottom right, there is a "next step >" button.

If the student or educator is unsure of where the component is located, he or she can click the “*Where am I located*” link button to see a magnified photo of the location of the component on the board. The step-by-step instructions have resulted in significant improvements in the CEENBoT assembly process. Much less educator time is needed to explain how to perform the construction process and the individual steps have eliminated most of the problems of placing components in the wrong location.

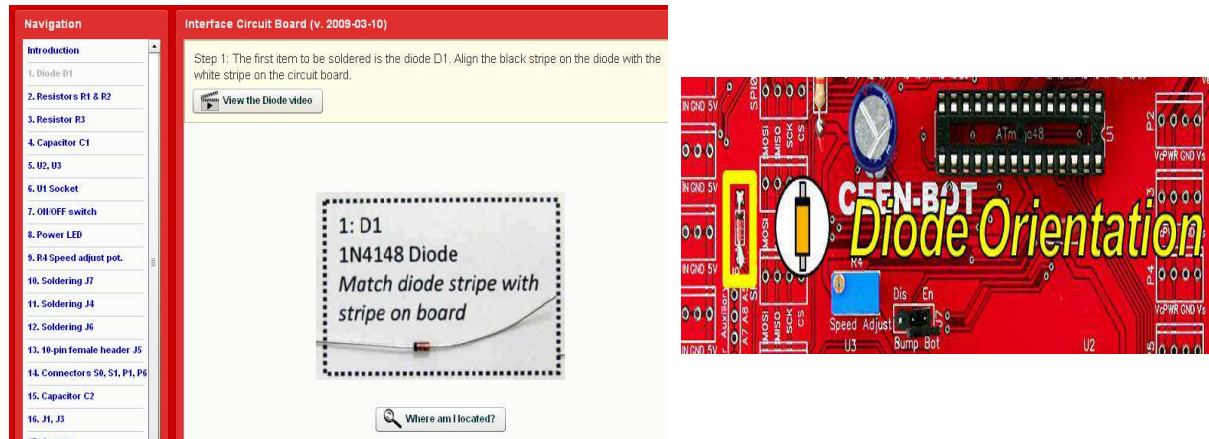

Graduate Course Results to Date:

As mentioned, to help with teacher training, the SPIRIT project is also striving to develop graduate courses and graduate course modules for educational robotics, where teachers will eventually be able to enroll online for graduate credit nationwide. This initial class effort focuses on the critical integration, articulation, and differentiation aspects of Science, Technology, Engineering, and Mathematics (STEM). The purpose of this graduate course strategy is to prepare graduate students to incorporate the research and practices of STEM education, especially within the context of educational robotics, at the elementary, middle and secondary levels. The dynamic nature of advancements in the core areas of STEM and educational robotics require that teachers be able to share current developments in a rapidly advancing technological environment, and thus, the course is striving to prepare teachers of STEM coursework to meet the challenges of their educational profession in a changing world. Four overarching course themes include: Understanding the importance of STEM education, the use of robotics in the curriculum, designing and implementing immersive learning environments, and encouraging curiosity and problem solving. The prototype graduate class meets currently in a hybrid fashion including a traditional classroom environment with a mix of online collaboration and learning. Eventually, it will be offered fully online to interested teachers around the country. The course has been offered in smaller prototype formats to date (N=83 students) and received some encouraging evaluations from the participating teachers. Using a 5-point scale, ranging from a score of 1 (which represented strongly agree) to a score of 5 (which represented strongly disagree) the course participants responded that they were “satisfied with the amount I learned in the course” (mean of 1.69); “this course was well organized” (1.88), and that “this course helped me to think in new ways” (1.31).

In support of new graduate course efforts, that project has helped to establish the Office of STEM Education in the College of Education at UNO. This will allow online courses in educational robotics and STEM to be continued for far into the future. The Office of STEM Education is already establishing a reputation as a national leader in STEM education. The office is focused on many aspects of STEM education (with a focused educational robotics effort in SPIRIT) including improving teacher training, increasing the number and diversity of STEM teachers, providing innovative STEM curriculum, and researching STEM education interventions. The core leadership of the office includes five UNO science, technology, and mathematics education professors, a multi-cultural professor, and two UNO educational technologists. There are also 11 professors from other colleges who participate on a campus wide committee for STEM that work routinely with the Office of STEM Education. The STEM Office faculty members have won several awards in the past few years, including named professorships, the Alumni Outstanding Teaching Award, the UNO Research and Creative Activities Award, the Chancellor's Medal, the NASA Mission Home Award, and the UNO outstanding staff member.

The UNO Office of STEM Education is committed to improving science, technology, engineering, and mathematics education. The SPIRIT project is perfectly aligned with this commitment. It is a strong belief of the Office that the two key elements for change should be 1) viewing these four areas of STEM as an instructional opportunity, with teaching being done in context and always taking advantage of the interconnections of the STEM areas. It is a further belief that the common "silo" teaching of STEM concepts (where disciplines are not connected in anyway), has not given students the necessary experiences to see the value of learning STEM concepts, as well as not giving them the needed "habits of mind" related to STEM literacy that our current and future society needs, and 2) all students should experience relevant and vibrant STEM education. In the recent National Science Board report "Preparing the Next Generation of STEM Innovators," recommendation #2 states a need to "to nurture potential in all demographics of students." We have observed that too often, the focus of STEM education has often been on only the "top" students. The SPIRIT project, with the ongoing support of the Office of STEM Education, is committed to helping innovations in STEM Education serve all students, as represented by the powerful context of educational robotics.

Teacher Training Results to Date:

In pursuit of its curriculum development effort and as of December 2011, a total 305 teachers have now been trained in extended summer workshops, graduate courses and credit-based independent study options. Many of these teachers have also developed lessons and curriculum materials for their own classroom, which became some of the raw material for further SPIRIT lesson development and for related educational materials that have been indexed within the SPIRIT database and website (such as an engineering notebook), after significant refinement and editing by the SPIRIT team.

To date, a total of 54% of the trained teachers have been female and 8% have been minority teachers. The female participation has been encouraging, since the SPIRIT project has been especially interested in getting the participation of women teachers. An extensive teacher survey was given at the beginning of the training experiences (particularly summer institutes) and then again at the end. The beginning survey asked for basic biographical information, professional qualifications, teaching experience, and professional development. A series of questions also measured perceptions about project-based learning (PBL) and

science, technology, engineering and mathematics (STEM). Another set of questions was designed to measure participants' evolving experiences and expectations with the SPIRIT project. The ending survey repeated the PBL and STEM questions and asked three specific open-ended questions about the teachers' experiences of the professional development experience that they had just completed. Responses to the open-ended questions were reviewed and coded into categories. Reliability of the subscale for perceptions about PBL was measured using ten items. Cronbach's Alpha for the PBL scale was .75, which is a moderate level of reliability. Reliability of the subscale for perceptions about STEM was measured using only 10 of the 13 items administered, as three items did not perform well and were adversely affecting reliability of the scale. Using just the 10 acceptable items, Cronbach's Alpha was .75, which is an acceptable level of reliability.

SPIRIT Summer Institutes have now been undertaken in a total of five summers. Three summers were related to the initial SPIRIT-ITEST Project that focused on teacher professional development, and involved a total of 97 teachers, and one summer replicating the SPIRIT model with a small state funded grant, involving 22 teachers. Training in the first three years (2006-2008) took place at the Peter Kiewit Institute in Omaha, Nebraska and the training was in 2009, and conducted at Central Community College in Columbus, Nebraska. The Columbus training was also trying to see if the training could be replicated at a community college, if given some relatively basic help from the SPIRIT education and technical teams. This training effort was paid for by a small grant from the Nebraska Department of Education (requiring no NSF funding), and closely followed the model established with NSF funds, and was an attempt at working toward sustainability of the summer training institutes. The fifth summer of training this last summer (2010) involved 23 lead teachers from the Dream It Do It (DIDI) organization, representing 11 rural districts from Nebraska. This training was split across the summer and in Saturday sessions during the regular year. Training during the summer of 2011 was done with single day training sessions in various locations, both on and off the UNO campus.

For the 97 teachers trained in the first three summers (2006-2008) the results of the teacher survey were relatively encouraging from year to year. The questions that evaluated participants' perceptions of PBL and STEM education asked teachers to rate their agreement to a variety of statements using a five-point scale ranging from "strongly disagree" to "strongly agree." For analysis purposes, and to reflect the ordinal level of data within the assessment instrument, the scale presentation was transformed to a numeric scale of 1 to 4. Dr. Mike Timms, the managing director of the NSF Center for the Assessment and Evaluation of Student Learning (CAESL) suggested this modified analysis approach. Stronger agreement (higher scores) on the scale indicated that teachers had greater familiarity with PBL and STEM, and that they valued them as beneficial to their students. There were distinct changes in how experienced teachers felt on a number of aspects of the content and teaching covered.

The following summarizes the perceptions of the teachers from the five years of data that have been collected to date in the SPIRIT project, three funded by the initial ITEST project (2006-2008) in Omaha, Nebraska, and the fourth funded by the Nebraska Department of Education (2009) at the community college in Columbus, Nebraska, and the fifth (2010) in various locations in Nebraska, as funded by Dream It Do It. Data from the summer of 2011 was only general feedback data on perceived effectiveness due to the short duration of the teacher training activities. Later workshops represent a replication process

and a step toward sustainability of the teacher training, where the community colleges and other organizations (such as Dream It Do It) might sponsor or undertake the educational robotics teacher training with guidance from the SPIRIT team. It was felt that community colleges and other educational organizations would be a good source for host professional development sites with the potential expansion of educational robotics support across the nation. We have been pleased about these collaborative efforts to date.

The initial teacher training results from the first three Omaha workshops now follow, which used a more focused design over a period of 2 weeks. The first cohort of teachers' ratings on five of the seven factors that were components of the workshops increased one category on the four-category scale. In engineering, electronics, and robotics, teachers moved from expressing, on average, no experience to feeling that they have a low amount of experience as a result of the workshops. On their average ratings for computers and project based learning, they moved up from low to medium. In the 2nd cohort, participating teachers' perceptions of their experience also increased, but only on two topics. The changes occurred in engineering and robotics, two of the major themes of the workshop. In the 3rd cohort, teachers' perceptions of their experience changed the most, which was likely attributable to the fact that there was a greater proportion of beginning teachers in the group (i.e., teachers with 2 years or less experience), so their room for growth was greater. In all cohorts, teachers' perceptions changed the most in the specific topics that were a particular focus of the workshop trainings, which primarily included engineering, electronics and robotics.

| Changes in Teacher Perceptions from SPIRIT Trainings (Cohorts 1-3) | | | | | | | | | |
|---|-----------------|--------------|---------------|-----------------|--------------|---------------|-----------------|--------------|---------------|
| | Cohort 1 | | | Cohort 2 | | | Cohort 3 | | |
| General Experience in | Before | After | Change | Before | After | Change | Before | After | Change |
| Engineering | 1 | 2 | 1 | 1 | 2 | 1 | 1 | 3 | 2 |
| Electronics | 1 | 2 | 1 | 2 | 2 | 0 | 1 | 3 | 2 |
| Robotics | 1 | 2 | 1 | 1 | 3 | 2 | 1 | 3 | 2 |
| Programming | 2 | 2 | 0 | 2 | 2 | 0 | 1 | 2 | 1 |
| Computers | 2 | 3 | 1 | 3 | 3 | 0 | 2 | 3 | 1 |
| Cooperative Learning | 3 | 3 | 0 | 3 | 3 | 0 | 2 | 3 | 1 |
| PBL | 2 | 3 | 1 | 3 | 3 | 0 | 2 | 3 | 1 |

The teachers in the sustainability replication trained at Central Community College were also asked to rate their level of experience in the seven topics that were covered in the workshop training. In three of the seven categories, (Engineering, Robotics and Cooperative Learning) teachers' most common rating (mode) increased one category. These results were similar to those observed in the second year of the previous SPIRIT project, but not as high as those seen in the first and third years.

| Changes in teacher perceptions (Replication Cohort 4) | | | |
|--|---------------|--------------|---------------|
| General Experience in... | Before | After | Change |
| Engineering | 2 | 3 | 1 |
| Electronics | 2 | 2 | 0 |
| Robotics | 1 | 2 | 1 |
| Programming | 2 | 2 | 0 |
| Computers | 3 | 3 | 0 |
| Cooperative Learning | 3 | 4 | 1 |
| PBL | 2 | 2 | 0 |

In further analysis at the community college replication site, the mean scale score for teachers on the PBL scale rose from 2.7 at the start of the workshop to 3.1 at the end, which was a statistically significant increase ($p < .001$, $t = 4.23$, $df = 17$) although it was not a full category increase. Similarly, the mean scale score for teachers on the STEM scale rose from 3.0 at the start of the workshop to 3.4 at the end, which was also statistically significant increase ($p < .001$, $t = 4.04$, $df = 17$), even though it was also not a full category increase.

Teacher training assessment that occurred for the fifth cohort, the Dream It Do It organization was undertaken with less extensive teacher survey work than previous years, due to a more flexible group setting, where teachers could come and go at various training sessions, and bring colleagues for various events through out the year. Surveys instead focused on providing feedback from individual sessions and teacher requests for particular information on various topics. Feedback surveys varied for particular sessions, but surveys were overall very positive, and typically between 4 and 5 on the Likert Scales, representing between agree and strongly agree that the professional development sessions were beneficial to teachers. In these sessions new capabilities of the CEENBoT were also introduced to teachers, including the Graphical Programming Interface and the Graphing Calculator Interface. Both these new innovations were particularly well received by teachers with some of the highest rankings of any training sessions. Further teacher training feedback will be more systematic, and more compatible with this new flexible professional development format provided in various sessions over the duration of a year, rather than in a single summer. Teacher training undertaken in the Summer 2011 used single day feedback forms. Likert scaled items again scored typically between 4 and 5 for all items, representing agreement and strong agreement by teachers that the sessions were effective.

In all of the teacher professional development institutes, teachers made many positive comments in open-ended survey questions about how they had been impressed by and learned from the hands-on laboratory sessions in the workshop. More than a quarter of the comments were about the building of the robots. Participants in all years felt that the workshop in general, as well as the session on developing lesson plan ideas and sharing them, would be very helpful with planning instruction for their students. Teachers also commented that they had gained a better appreciation of engineering in general and the course and career opportunities that could be open to their students. Teachers also commented favorably about the diversity of experience of the workshop presenters



and the enthusiasm that they brought to the topics they facilitated. Also, they liked the opportunity to work with other teachers and felt that the sessions gave them “concrete examples for applying in the classroom.”

In all cohorts, the comments about potential improvements to the workshops primarily related to spending more time on various topics, in particular on the construction of the robot and the associated electrical theory and electronics. Approximately one-half of improvement suggestions were about improving the content of sessions, the time devoted to particular sessions, and the presentation strategy. Teachers found the content of the workshop challenging both in learning about electronics and engineering, and in developing some of the skill subsets needed like soldering.

Student Criterion Referenced Test (CRT) results:

As an initial preparation for more formal pilot and field-testing of the SPIRIT activities, the project leadership worked closely with the Omaha Public Schools early in the project to investigate possible patterns within the student criterion-referenced test scores of the students taught by the SPIRIT trained teachers. A total of 29 groupings of these mathematics and science test scores (representing N=1058 students) have been examined and have been compared with school and district averages. Some groupings at the 7th and 8th grade levels represented multiple classes of a teacher. Of the 29 groupings of students examined, represented by their teacher's participation in a SPIRIT workshop, a total of 21 groupings (72.4%) scored above their school averages on the related criterion referenced tests in mathematics and science, and a total of 23 groups (79.3%) scored above their district averages. The limitations of using district developed criterion referenced test scores were quickly apparent within this analysis, and a significant limitation was identified, in that these assessments might be taken, or even retaken, at various times in the school year.

Thus, although this very limited evidence cannot directly support any possible cause and effect conclusions, it was still encouraging, since many of these SPIRIT groupings are taken from some of the traditionally poorest performing schools in the Omaha Public School system. The SPIRIT leadership team selected teachers are now engaging in more carefully controlled pilot tests and field tests

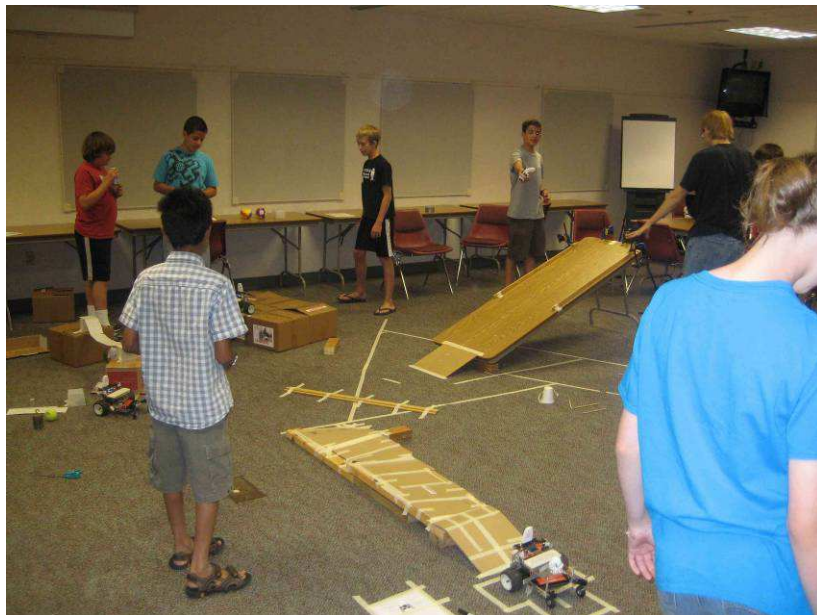

where more consistent assessments are used.

| SPiRiT Student Criterion-Referenced Test Score Comparisons (2008 and 2009 Scores) | | | | | | |
|--|-----------------------|-----------------------|--------------------------|-------------------------|--------------------------|--|
| Group, Grade, N = (CRT Number) <i>Total N = 1058</i> | CRT SPiRiT | CRT School | SPiRiT above? | CRT District | SPiRiT above? | |
| Group 1: 5th, N=22 (Math) | 89.4% | 92.3% | Below | 88.9% | Above | |
| Group 2: 5th, N=22 (Science) | 90.7% | 77.8% | Above | 75.3% | Above | |
| Group 3: 5th, N=19 (Math) | 94.7% | 87.5% | Above | 81.1% | Above | |
| Group 4: 5th, N=22 (Math) | 90.9% | 92.3% | Below | 81.2% | Above | |
| Group 5: 5th, N=23 (Math) | 100.0% | 85.9% | Above | 81.2% | Above | |
| Group 6: 5th, N=8 (Math) | 87.5% | 86.1% | Above | 81.2% | Above | |
| Group 7: 5th, N=19 (Science) | 100.0% | 88.8% | Above | 88.9% | Above | |
| Group 8: 5th, N=22 (Science) | 100.0% | 96.9% | Above | 88.8% | Above | |
| Group 9: 5th, N=23 (Science) | 100.0% | 95.8% | Above | 88.9% | Above | |
| Group 10: 5th, N=8 (Science) | 87.5% | 91.7% | Below | 88.9% | Below | |
| Group 11: 6th, N=14 (Math) | 85.7% | 78.0% | Above | 75.3% | Above | |
| Group 12: 6th, N=16 (Math) | 62.5% | 78.0% | Below | 75.3% | Below | |
| Group 13: 6th, N=16 (Science) | 87.5% | 51.2% | Above | 75.3% | Above | |
| Group 14: 6th, N=25 (Math) | 88.0% | 91.4% | Below | 73.5% | Above | |
| Group 15: 6th, N=9 (Math) | 66.7% | 64.7% | Above | 73.5% | Below | |
| Group 16: 7th, N=74 (Science) | 78.8% | 68.6% | Above | 68.6% | Above | |
| Group 17: 7th, N=95 (Math) | 85.1% | 83.9% | Above | 84.5% | Above | |
| Group 18: 7th, N=26 (Math) | 93.4% | 83.9% | Above | 84.5% | Above | |
| Group 19: 7th, N=100 (Science) | 79.6% | 76.9% | Above | 68.6% | Above | |
| Group 20: 8th, N=76 (Math) | 87.5% | 86.1% | Above | 84.5% | Above | |
| Group 21: 8th, N=46 (Math) | 97.0% | 86.1% | Above | 84.5% | Above | |
| Group 22: 8th, N=79 (Math) | 89.4% | 86.1% | Above | 84.5% | Above | |
| Group 23: 8th, N=28 (Math) | 99.4% | 86.1% | Above | 84.5% | Above | |
| Group 24: 8th, N=14 (Math) | 94.9% | 86.1% | Above | 84.5% | Above | |
| Group 25: 8th, N=13 (Math) | 75.0% | 83.9% | Below | 84.5% | Below | |
| Group 26: 8th, N=11 (Math) | 57.7% | 83.9% | Below | 84.5% | Below | |
| Group 27: 8th, N=19 (Science) | 56.2% | 68.6% | Below | 68.6% | Below | |
| Group 28: 8th, N=118 (Science) | 78.8% | 76.9% | Above | 68.6% | Above | |
| Group 29: 8th, N=112 (Science) | 77.8% | 76.9% | Above | 68.6% | Above | |

Limitations of District Criterion Referenced Tests and Assessments Efforts:

In our initial investigations of student criterion-referenced test data, and in curriculum-related pilot tests and field tests, we have found that the use of existing criterion-referenced test scores available from districts are substantially limited in their ability to measure student achievement within this project's context. From our data analysis, it is apparent to us that district criterion-referenced test score limitations include the following:

- a) Limitations Related to CRT Teacher Administration: Because teachers can have their students retake the CRTs as desired, there is a significant testing difference in how teachers complete this retake process, and thus the scores don't compare reliably across classes, even within a specific school or district.
- b) Limitations Related to District CRT Variation: The Nebraska (and other state) CRTs vary widely across districts, and thus, it is difficult to use these instruments across districts for effective pilot testing and field-testing efforts that mix schools or districts.

- c) Limitations Related to District CRT Timing: The timing of the CRTs also vary widely from teacher to teacher, and district to district, making the variable timeline of a pre-test to post-test schedule a significant limitation.

Thus, for the further pilot and field-testing of the evolving SPIRIT curriculum, we have decided to use a different strategy for looking at academic performance that is more reliable across districts and teachers. Conveniently, a sister project that we are closely collaborating with, the 4-H Robotics and GIS/GPS Scale-Up Project (NSF #0833403) has developed instruments that we help to refine, use and modify (and have started to use in limited ways already) that include a STEM content test, a STEM attitudes/interests test, a 21st century skills reflection, and a longitudinal coursework instrument. The content and attitude tests have already been refined, and the 21st Century Workplace and Longitudinal Instruments are currently being refined. We are also working closely with the 4-H Robotics Project in the sharing of data collection strategies and assessments, which essentially map nicely to both projects, since some districts are integrating educational robotics both during the school day (the focus of SPIRIT) and in after school programs and summer camps (the focus of 4-H Robotics). This cooperation between our two NSF projects is permitting a much better comparison across interventions and is more promising for curriculum pilot and field-testing. A more detailed description of the instruments now follows:

1) STEM Concepts Test: This content focused instrument is a 37-item, paper-and-pencil, multiple-choice assessment, covering a variety of STEM topics including computer programming, mathematics, geospatial concepts and engineering/robotics. The assessment is based on a previous 24-item robotics assessment instrument that demonstrated a Cronbach's alpha reliability coefficient of 0.86 (Barker & Ansorge, 2007). Two experts from Carnegie Mellon University's Robotics Academy and two engineers from the University of Nebraska at Lincoln Department of Biological Systems Engineering Department validated the assessment instrument's content. The overall Cronbach's alpha reliability coefficient of 0.798 is currently reported for this instrument. New versions of the test are also being conceptualized and created.

2) Student Attitudes/Interests Test: This instrument was modeled after the Motivated Strategies for Learning Questionnaire (Pintrich, et al., 1991). The questionnaire focuses on the following eight constructs: task values/attitudes for science, mathematics, robotics and GPS/GIS, problem solving/critical thinking, teamwork cooperative learning/teamwork, self-efficacy in robotics and self-efficacy in GPS/GIS. The task value for science includes questions like "It is important to me to learn how to conduct a scientific investigation." The mathematics task value construct includes questions like "It is important for me to learn how to make accurate measurements to help solve mathematical problems." The robotics construct asks questions like "It is important for me to learn about robotics." The GPS/GIS construct includes questions like "It is important for me to learn about GPS." In addition, problem solving skills (i.e. "I try new methods to solve a problem when one does not work") and teamwork constructs (i.e. "I like being part of a team that is trying to solve a problem") are also included. Finally the instrument examined self-efficacy in robotics and GPS/GIS concepts. The overall Cronbach's alpha reliability coefficient of 0.94 was reported as an average for previous administrations of the post attitudinal instrument. The SPIRIT project

will also soon be adding GPS activities, so these additions make this new instrument particularly relevant.

3) 21st Century Workplace Skills Reflection: This instrument, which is currently undergoing further validation and refinement, includes 21 questions that ask students about common workplace skills such as speaking, writing, and listening, within a STEM context. The instrument is based on the Secretary's Commission on Achieving Necessary Skills (SCANS) report. The 21st Century Workplace Skills Reflection instrument has been increasingly requested by educators involved in both the SPIRIT and 4-H Robotics projects.

4) Longitudinal Instrument: This instrument has been designed to ask students about their interests in high school STEM coursework, and why they are interested in such coursework, within a set of questions in each of seven short reflection sections. The instrument has been designed so that it can also be used to track students within a particular school or district, to see if students take more STEM coursework, after experiencing a course, club, or summer camp with educational robotics.

5) Big Ideas Open Ended Questions Instrument: This instrument has been designed to ask students about seven "Big Conceptual Ideas" that are targeted in the SPIRIT Project, including: What is a robot?; What is a variable?; What is the engineering design process?; What is a computer program?; What is science?; What is mathematics?; and How are robots used in real life? These questions are then consensus scored between pretests and posttests by a group of three or more teachers external to the classroom setting.

In addition to the key instruments described above, two short lesson feedback surveys are also being used in the SPIRIT curriculum refinement process, to receive formative feedback from teachers and students who pilot particular SPIRIT lessons and activities, and then provide revision suggestions to potentially improve the lessons. These feedback forms ask teachers and students how they liked the lessons, what they believe they learned in the lessons, and how the lessons might be improved.

Finally, the State of Nebraska has also developed an online career planning assessment for middle school and high school students that will be used in selected pilot testing and field-testing efforts for the evolving SPIRIT curriculum, as a way to eventually include student career interest in later analyses.

Status of Initial Pilot Testing, Field Testing and Test Site Agreements:

In 2012, as our SPIRIT efforts are now moving into more extensive pilot testing of lessons and field-testing of lesson sets (with various curriculum components) we plan to steadily expand and refine the curriculum. We have initiated further work with area school districts to assist in the pilot and field-testing process, as well as to provide control groups of students (who will not be using educational robotics) to permit comparisons. We are also working toward larger field-testing efforts, where large groups of lessons would be tested over a longer duration (such as a summer session or full semester) and involve larger

numbers of sequenced lessons. These pilot testing and field-testing agreements have evolved steadily, and include the following progress:

- 1) We have continued our Institutional Review Board approvals from the University of Nebraska Medical Center for permission to undertake pilot testing and field-testing with 12 different area school districts within the Metropolitan Omaha Education Consortium (MOEC). This includes an excellent diversity of students and educational settings. The IRB approval number is: 443-09 EX.
- 2) We have already successfully conducted small short duration pilot test sessions of three-hour durations, with 141 students, at Educational Service Unit #3, an educational support facility serving the MOEC schools. These results have been encouraging, particularly related to student STEM attitudes (described in next section). We are continuing short duration pilot testing as we move toward longer duration testing.
- 3) We have worked with Lewis and Clark Middle School (Omaha Public Schools) to undertake a longitudinal SPIRIT robotics field test effort. We did some pilot activities and field tests with students during 2010 and 2011, and will undertake further field testing in 2012. This has involved 140 students to date in science and technology innovation classes and will continue to expand. In 2012, they will undertake a well-sequenced set of educational robotics lessons that also includes the building and testing of CEENBoT robots.
- 4) We are arranging another 2012 summer camp to be held at Daniel J. Gross High School in Omaha. This SPIRIT educational robotics camp will build upon the successful 2010 and 2011 summer camp efforts, and involve both middle school and high school students. Rigorous data collection will be undertaken at the 2012 camp.
- 5) We have trained 12 STEM teachers at Lincoln Northeast High School, and an outside funder contributed 70 CEENBoTs to the school. We are now working with the Lincoln Northeast faculty and administrators to plan curriculum-based uses of the CEENBoTs and the integration of the SPIRIT curriculum and lessons. This high school is very engaged, and evolving to be an excellent partner in the SPIRIT 2.0 project.
- 6) We are organizing additional camps and interventions of two to five days duration each that will also undertake smaller field-tests of various sets of SPIRIT lessons, and that will be held at several locations in Nebraska. The efforts build on the 2010 and 2011 efforts and 2012 efforts will field-test a set of sequenced lessons and activities from the curriculum.
- 7) We are now working with 13 school districts in the Dream It Do It organization of Nebraska for field-testing efforts. Each of these school districts, with both rural and urban settings, have had several teachers trained in the SPIRIT Robotics

curriculum, and received from 7 to 10 CEENBoTs. The schools have agreed to try out sets of lessons, and to also collect field test data that includes student STEM content knowledge and STEM interests. The SPIRIT Education team is working closely with these districts.

- 8) We are successfully arranging further control group sessions for this 2012. As a reward for district participation in the control group process, we are also scheduling a three-hour robotics event for students and teachers at each school district control group site, which would involve a set of robotics exploration stations that would be staffed by our team members (SPIRIT educators and engineers). This event would be conducted after the control group data is received. At a designated time period before the participation session, the teachers have the involved students take the STEM content and STEM attitude instruments. The teachers then bring those completed pretest instruments to the session, and take another set of tests before the event begins, to capture control group comparison information.

In summary, we have already had initiated agreements with the following organizations to assist in pilot testing and field-testing. Some efforts were conducted in 2010 and 2011 and more refined pilot testing and field testing will be undertaken in 2012. Other districts and organizations are now also expressing an interest in contributing to this process. The willingness for educational organizations to collaborate in the pilot testing and field-testing process is in itself encouraging, as this demonstrates the educational value and reputation that they already see in the SPIRIT curriculum. A full list of the pilot testing and field-testing partnerships are now provided.

- a) The Metropolitan Omaha Education Consortium (11 public school districts)
- b) Daniel J. Gross High School (private school - Catholic)
- c) The Omaha Public Schools (large urban public school district / high minority)
- d) Lincoln Northeast High School (large urban high school)
- e) Educational Service Unit #5 (representing 17 small rural school districts)
- f) The Papillion-LaVista Schools (moderate sized urban district)
- g) The Gretna Public Schools (moderate sized urban district)
- h) The Westside Community Schools (moderate sized urban district)
- i) Lewis and Clark Middle School (urban middle school / high minority)
- j) Educational Service Unit #3 (representing 15 small/moderate sized urban districts)
- k) Dream It Do It (representing 13 rural districts)

Pilot Test Results to Date:

Pilot testing during SPIRIT project to date encompassed two types of pilot testing formats, which included a short-term intervention of roughly three hours in duration as well as longer interventions that lasted for several days over a period of time. The short-term interventions undertook samples of up to three short lessons, while the longer pilot test interventions undertook four or more well-sequenced lessons. Each intervention was facilitated by a well-trained SPIRIT teacher.

Short-Duration Pilot Test:

A total of 141 students participated in the short-term pilot testing process for SPIRIT. These students were involved in three tests of individual SPIRIT lessons, lesson components, or robotics related activities. The lessons focused on: 1) algebraic slope, using robots to move up ramps, 2) the chemistry of batteries, moving a robot that was connected to different battery types, and 3) the physics of movement, by examining the movement of different robots. This short intervention activity was also collaborated closely with the Nebraska 4-H Robotics team who participated in some of the pilot activities. That partner grant project will soon be transitioning to the CEENBoT robot as their operational robotics platform.

The short-term intervention (pilot test) data was retrieved in a time series design process that included a first set of pretests (given about a week before the pilot activities), a second set of pretests (given right before the pilot activities), and a final set of posttests (given right after the pilot activities). The pilot activities lasted about 3 hours with students. The participating students were recruited through the Nebraska's Educational Service Units (ESU), a set of 19 state-funded educational support organizations. The ESUs sent e-mails to schools and curriculum leaders in the Omaha area inviting their participation in the research. Schools were asked to try to target a mix of student abilities, interests, gender, and ethnicities to reflect the school's general population of students. They were asked to avoid having only interested or high ability students participate. The resulting group of 141 students was 74% male, 20% minority, and had a mean age of 11.39 years.

The content learning instrument used in the pilot testing process was from the 4-H Robotics Project and was a 37-item, paper-and-pencil, multiple-choice assessment, covering mathematics (including fractions and ratios), geospatial concepts (coordinate estimation based on location), engineering (such as gears and sensors), and computer programming (such as looping and multi-tasking). Two experts from Carnegie Mellon University's Robotics Academy and two engineers from the University of Nebraska at Lincoln Biological Systems Engineering Department had previously helped to validate the assessment instrument's content. The same instrument was used as the pre- and post-test, and a Cronbach's alpha reliability coefficient of .80 was reported for the administration of the posttest.

The attitude instrument given to the participating students, consisted of 33 Likert scale items, and was also from the 4-H Robotics Project. It was modeled after the Motivated Strategies for Learning Questionnaire (Pintrich, Smith, Garcia, & McKeachie, 1991) and included two subsections focusing on motivation and the use of learning strategies. The overall Cronbach alpha reliability of this instrument computed earlier by the 4-H Robotics team was .95, with individual scale alphas running from .64 to .88.

Pre-post learning results. Data was analyzed by Dr. Gwen Nugent, of the University of Nebraska Center for Research on Children, Youth, Families, and Schools. A dependent t-test showed that although there was a slight increase in content test scores (Pre M = 16.57, post M = 16.81), the increase was not significant ($t(131) = .91, p = .36$). Thus, these results indicated that the short-term pilot testing intervention focusing on relatively short duration lessons and lesson components did not significantly impact learning on the content instrument.

Pre-post attitudinal results. The attitudinal data sets from the short-term intervention were also analyzed by Dr. Nugent. A dependent t-test comparing overall attitude scores showed that there was a significant increase in attitudes for the youth experiencing the short-term intervention ($t(123) = 6.92, p < .0001, d = .62$). The mean attitude score increased from 4.09 (pre) to 4.34 (post). To provide more insight into these increases additional dependent t-tests were run for each of the attitude scale scores. All of the scales showed a significant increase. The time series non-intervention phase (acting as a control group process) indicated no significant increases.

Although the short-term pilot test intervention had no impact on student learning, we really did not expect this result for such short duration interventions, particularly since these shorter interventions were mainly about curriculum improvement, as well as building student awareness and interest. It would appear that three hours of robotics activities, no matter how interesting, engaging, and well facilitated, will probably not provide enough time to cover topics with sufficient depth and structure to promote student understanding as identified on this instrument. Students are of course introduced to certain educational robotics and STEM topics during these short duration events, as integrated into the activities, but the time constraints would not seem to allow for a full exploration of concepts and processes necessary to promote learning.

While the short-term pilot testing intervention did not have a direct impact on student learning as measured by the content assessment, it did impact student attitudes, as measured by that assessment. Students' attitudes towards science, mathematics, and technology all increased from pre to post, as well as their self-efficacy with robotics. This attitude improvement result is likely also due to the fact that the activities in the short-term pilot testing interventions were specifically selected and designed to be highly engaging and motivating, with limited cognitive load. As previously discussed, the short-term nature of the pilot interventions also meant that the individual activities for this instructional setting could not contain extensive mathematics and science background material and the needed calculations to perform the tasks on this short intervention timeline. Similarly, the short duration activities could not illustrate the complete scientific inquiry or engineering design processes, which may have led to a relatively superficial content focus for these shorter pilot tests. This emphasis on the affective, as opposed to cognitive, domain appeared to contribute to the more positive views of youth in the short-term pilot intervention.

Short-term robotics interventions will continue to help us to pilot test selected elements of the SPIRIT curriculum, and also appear to be a successful way to impacting student STEM attitudes and getting students excited about robotics in general. The shorter duration pilot tests also allow us to get direct feedback for lesson improvement, using short feedback forms given to both the students and educators on how the pilot activity went, and how it could be improved. Two sample feedback forms that we currently use are included in the report appendix.

Shorter duration pilot tests also help to provide a nice reward strategy for the schools and districts that are willing to act as control group settings for us, since we can then offer them a short duration robotics event in return for piloting shorter duration lessons, that would be provided after the control group data is collected. This later robotics event may also perhaps serve a motivational role to encourage both youth and educators to seek out additional opportunities to explore educational robotics in greater detail.

Longer Duration Pilot Tests:

Three SPIRIT teachers were asked to undertake longer duration pilot tests with selected lessons of the SPIRIT curriculum over a full semester. In this process, the teachers selected eight or more lessons that would be most aligned with their curriculum. Lessons were piloted approximately every two weeks or so, and aligned with the current content responsibilities of the course. The pilot classes were generally small, due to requests from the participating school districts. Three teachers and three different classes were involved, including a middle school mathematics class (N=12), a middle school innovations science class (N=18), and a high school special engineering topics seminar (N=7). Lessons were all carefully selected, sequenced and aligned with the curriculum. Control groups were very difficult to establish in this field-testing effort. Since the same age student had participated in the short duration pilot tests (N=141), and those pilot tests had used a time series design (pre-pre-post) with a no intervention phase, that data was used as a very limited comparison group. The same content and attitude instruments (as described earlier) were also used in all the groups being examined.

The middle school mathematics teacher selected eight lessons that aligned generally with topics in introductory algebra, and undertook a one to two hour educational robotics lesson about every two weeks. The 12 participating students took the content and attitude instruments at the beginning and at the end of the semester. A total of seven males and five females participated. Using a dependent t-test, the students' scores were examined for both the content and attitude instruments. For the content instrument, a dependent t-test showed that there was a slight but significant increase in content test scores, and particularly mathematics questions (Pre M=13.25, S=3.98; Post M=15.00, S=3.02), which was significant ($t(11) = 2.83, p = .016$). For the attitude assessment, another dependent t-test was also used. The attitude scores also showed a significant increase (Pre M=127.5, S=23.6; Post M=140.3, S=17.61), which was significant ($t(10) = 3.23, p = .010$).

The middle school innovations science teacher selected eight lessons that aligned generally with topics in engineering and technology invention, and also piloted a one to two hour educational robotics lesson about every two weeks. The 18 participating students took the content and attitude instruments at the beginning and at the end of the semester. A total of ten males and eight females participated. Using a dependent t-test, the students' scores were examined for both the content and attitude instruments. For the content instrument, a dependent t-test showed that there was only a small increase in content test scores (Pre M=14.0, S=3.43; Post M=14.5, S=3.36), and was not significant ($t(17) = 0.67, p = .509$). For the attitude assessment, another dependent t-test was also used. The attitude scores also showed only a small increase (Pre M=130.0, S=13.9; Post M=132.1, S=9.96), and was again not significant ($t(16) = 0.73, p = .471$).

The high school engineering seminar teacher selected eight lessons that aligned generally with topics in engineering design, and also piloted a one to two hour educational robotics lesson about every two weeks. The 7 participating students also took the content and attitude instruments at the beginning and at the end of the semester. These students were ninth graders and represented a total of seven males participated in the all male seminar class. Using a dependent t-test, the students' scores were examined for both the content and attitude instruments. For the content instrument, a dependent t-test also showed that there was only a small increase in content test scores (Pre M=18.8, S=3.23; Post M=19.1, S=3.71), and was not significant ($t(6) = 0.31, p = .766$). For the attitude

assessment, another dependent t-test was also used. The attitude scores also showed only a small increase (Pre M=130.3, S=8.9; Post M=136.6, S=12.7), and was again, not significant ($t(6) = 1.04, p = .338$).

Some Pilot Test Interpretations and Strategy Modifications for Field Tests:

In some ways, the longer duration pilot tests had similar results to the shorter duration pilot testing effort, and illustrated that it is easier to increase student attitudes in this context than it is to increase student content knowledge. In fact, increasing student content knowledge was found to be quite challenging in this context, with only a small but significant increase in the class of the middle school mathematics teacher, while the other two longer pilot tests, and the short duration pilot test group all experienced no significant content increases, as measured by the content test. However, attitude improvement was somewhat more encouraging, with attitudes improving in the shorter duration pilot tests (N=141) as well as the middle school mathematics teacher longer pilot test (N=12). The attitude results also tended to be slightly improved in the other sections, but not to a level of statistical significance.

One study limitation that became obvious in the longer duration pilot-testing process was that the content testing process needed to be better aligned with the specific content being taught. The SPIRIT team better planned the field-testing process for later 2010 and 2011 to help teachers focus on content, as well as undertook revisions to the content testing instrumentation, to include more specialized questions focused on particular coursework threads, such as introductory algebra. In addition, the teachers for later field-testing on content were asked to carefully study the chosen curriculum activities ahead of time, and to see how these activities might directly emphasize the targeted content. If desired, a SPIRIT team member was available to discuss how on how a particular lesson might be used to emphasize instructional content.

2010 Field Test Study of the SPIRIT Lessons in Middle School Robotics Camp

A set of more focused field tests of the CEENBoT robotics platform using lessons and activities from the SPIRIT website were undertaken in 2010 and 2011. Each of these carefully controlled tests was conducted at Gross High School, 7700 S 43rd St, Bellevue, Nebraska. The tests were conducted with full permission of the school, district, and parents.

The first set of field tests in 2010 consisted of two three day sessions, June 23, 24, 25, 2010 and July 14, 15, 16, 2010, starting at 9:00 AM and lasting until Noon on each day. The field test was facilitated by Mr. Steve Hamersky who teaches science and computer technology at Gross High School. The activities used during the field test were selected to test new features of the CEENBoT robotics platform such as the data display as well as the durability and usability of the platform.

The 2010 field test was organized as a robotics summer camp where the students paid \$40 to attend. Flyers were sent to area elementary and middle schools both public and private. The summer camp was intended to be a fun experience with more hands-on activities with the robots and less formal teaching. The summer camp format showed a wide appeal in that the first three day camp session filled and an additional three day camp session was added. The additional session lead to some confusion about which session to attend as some students had signed up for the second session, but attended the first which created an imbalance in the number of attendees in each field test. The first session had 22 participants

and the second session had only 7 participants. There were also 2 to 4 secondary school students who helped facilitate the sessions. The secondary school students helped the participants with robot operations and troubleshooting and helped setup the robot game activities that would conclude each day.

The learning materials used in the field test activities were selected from the cyber infrastructure with topics chosen to provide exciting and engaging hands-on work with the robot. An engineering notebook was also selected from the CEENBoT educational materials which contained an introduction to the engineering notebook and blank graph paper pages for drawing diagrams and recording data. Participants could use the engineering notebook to

plan strategies or write reflections on activities.

Ten CEENBoTs



were used during the field test which allowed most students to work in groups of two. The first session required two groups of three participants due to participants attending the wrong session. During the second session participants could each use their own CEENBoT.

The SPIRIT cyberinfrastructure contains lessons in the AEIOU format that include individual activities titled Asking, Exploring, Instructing, Organizing, and Understanding. As described earlier in the report, the lesson activities start by asking questions (A) to create interest and excitement that is followed by an open-ended exploration (E) of the concepts and skills related to the lesson topic. Once participants have had some experiences with the content they are ready for instruction (I) on the lesson topic. After instruction, an indepth study and data collection is completed and organized (O), and then the lesson is concluded with an activity that checks for participant understanding (U). Since this field test was part of a summer camp, the selected activities generally included the asking and exploring activities, with some instructing and organizing activities depending on the lesson. For some lessons, the organizing activity was substituted for the exploring activity, and the post-test on the last day of the camp was used to test for understanding. The instructors of the summer camp were pleased with the flexibility of the SPIRIT lesson activities.



The 2010 field test activities on the first day started with the content pre test and attitude surveys. Participants were introduced to working in the laboratory area safely and using the robots properly through an activity called Meet the Bot. Career opportunities in the STEM areas were discussed during the Asking portion as well as the basic operation of the CEENBoT robotics platform. Participants explored the circuit board and remote controls and practiced their robot driving skills. Computer programming opportunities and details were explored next in an activity called Reverse the Bump. The CEENBoT robotics

platform can operate in a bump mode where they will avoid collisions using infrared sensors. Participants explored how the robot would react to collisions when in the bump mode and then they were to develop the bump mode pseudo-code algorithm. The first day concluded with a game activity called the Bump Bot Derby where participants operated their robot in the bump mode and were required to move the robot from a starting point to a finish bulls-eye by bumping off two cardboard boxes. The participant placed the cardboard boxes first before starting their robot that required the use of the bump algorithm to plan the placement of the cardboard boxes.

The second day of the field test focused on motion such as distance, circumference, and speed, and electrical concepts such as current, energy and battery capacity. The latest CEENBoT robotics platform has a data display panel that shows numeric values such as revolutions, speed, current, and energy. The first activity called Go the Distance had participants explore distance, circumference, and speed culminating in a group graphing activity where the robots are used to plot a distance versus



speed graph. The second activity used electrical circuit kits (Snap Kits) to explore electrical current and voltage by building various circuits. Then the participants went back to the robots in the third activity called Juice the Bot and investigated the LCD data display of electrical current and energy, and collected data to plot an energy versus speed graph. The second day concluded with a challenge called Short Distance Run Around in which participants used their robot to knock down a random array of blocks trying to minimize the energy and revolutions.

The field test concluded on the third day with a challenge to modify the robot to play soccer. Participants were given some metal strips, bolts, tape, and a file folder and were asked to create an extension on the robot that could catch and pass a small soccer ball. After the modifications were complete the participants completed the post-test and surveys. Once the tests and surveys were complete, the participants used the robots to play a match of two-on-two soccer. The designs were quite diverse and effective as students were able to utilize the extra holes drilled into the CEENBoT chassis. The robot modification activity served as an illustration of many engineering concepts such as the engineering design process, problem solving, communication, and applied science.

The field test was evaluated with pre and post-tests and surveys consisting of three tools: a knowledge test, an interest survey, and longitudinal study survey (as detailed earlier). The knowledge test covered many topics that are typically part of a robot workshop with a longer time frame. The activities for this field test were not necessarily selected to cover all topics contained on the knowledge test. The surveys were designed to capture changes in the participant attitudes toward Science, Technology, Engineering, and Mathematics (STEM) content and whether participants might enroll in STEM courses in the future.

Survey and test analysis was done only for students that had turned in the parent consent form and that took both the pre and post-tests and surveys. For each test or survey

item, an increase in score was a positive change, a decrease was a negative change, and the averages used included both positive and negative changes. The pre and posttest and survey data for both sessions, June and July, were put together for analysis. For the June session there were 16 student tests included, for the July session there were 4 student tests included (81%, 19%). The ethnic and grade level distributions for the included tests and surveys were 18 white, 2 hispanic, and 1 black (85%, 10% 5%) and 3 grade six, 8 grade seven, 8 grade eight, and 2 grade nine (14%, 38%, 38%, 10%). The age and gender distributions were 4 at 11 years, 8 at 12 years, 7 at 13 years, 1 at 14 years, 1 at 15 years (19%, 38%, 33%, 5%, 5%), with 20 male and 1 female (95%, 5%). A series of paired t-tests were undertaken on the knowledge, interests, and expected high school coursework.

On the knowledge test there was an overall average increase of 9 correct answers from pre-test to post-test on the 33 questions test ($p < .05$). The questions with individual significant increases (of $p < .05$) involved questions related to the formula for distance, speed, and time (Q28, Q32), and the formula for circumference (Q36, Q37), which were topics included in activities done with the robot. The pre and post interest survey questions also showed an overall significant increase of a score of 129 to 132 ($p < .05$), and with stronger agreement of interest ($p < .05$) between pretest to posttest, with individually significant increases in questions related to using the scientific method (Q13), mathematical formulas (Q14), the engineering design process (Q20), and collaborative team work (Q29, Q30).

The expected high school coursework study (longitudinal) survey showed an increase on the instruments Likert scale of at least a 0.50 average change (out of 5) indicating significant increases ($p < .05$) in the perceived likelihood toward future study in calculus, computer science, and Earth science (Q3), and an increase in the expected educational degree level (Q4), and an increase between 0.25 and 0.50 average change in attitude toward further study in pre-calculus, physics, environmental science (Q3), and use of global positioning systems (Q7). This 2010 field test did not include activities using GPS, but students seem to have an interest in that area as shown on the interest survey (Q24, Q27).

The 2010 field test demonstrated a number of positive aspects involving the use of robotics in the educational environment including student motivation, lesson activity format, and robotics platform features. Using robots in the summer camp field test doubled the normal enrollment over the other summer camps that utilized computer based activities and required that a second session be opened for the additional robotics camp participants. The AEIOU lesson activity format proved to be very useful and adaptable to different uses and situations. The instructors felt that the cyberinfrastructure provided an efficient means to search and select lessons and the AEIOU format provided a structure that facilitated the adaptation of lessons to this specific camp offering. The summer camp environment tends to be less academic than class work done during a regular school session. The summer camp activities were developed mainly from the asking, exploring, and instructing portions of the lessons with some organizing added as well. Students responded



well, seemed to be motivated by asking questions, enjoyed exploring science and mathematics concepts with the robot, and were interested in learning more about robot operations through instruction. The CEENBoT robotics platform supported the activities and through the exposed structure, circuit boards, and motors, motivated the students to learn more about related science and engineering concepts. Students showed an immediate interest in modifying the robot through reprogramming or structural changes and seemed to really enjoy modifying the robot for use in the soccer activity.

2011 Field Test Study of SPIRIT Lessons in Middle School Robotics Camp

Two 2011 field tests of the CEENBoT robotics platform using lessons and activities from the SPIRIT website were conducted at Gross High School, 7700 S 43rd St, Bellevue, Nebraska. The first 2011 field test was offered during the winter break on Tuesday December 28 and 29, 2010 from 9:00 AM to 2:00 PM. The second 2011 field test was offered during summer break on Monday July 18 and Tuesday July 19, 2011, and again on Wednesday July 20 and Thursday July 21, 2011 from 9:00 AM to 2:00 PM. The field tests were again facilitated by Mr. Steve Hamersky who teaches science and computer technology at Gross High School. The activities used during the field tests were selected to test new features of the robotics platform such as the data display and graphical programming as well as the durability and usability of the platform.

The 2011 field tests were organized as a robotics winter break camp and two sessions of a summer break camp. Students paid \$40 for the winter break camp and \$50 for the summer break camp. For the winter break camp special flyers were mailed directly to the home of students using a middle school student information database maintained by Gross High School. The flyer was designed to strongly market the camp and included an incentive to attract more female participants. A female participant could bring along another female friend and the second female friend would pay half price. The marketing information for the summer break camp was included in a flyer along with other Gross High School summer camps such as sports and art camps and again mailed directly to the homes of students and sent in batches to area middle schools for distribution to potential participants. The summer camp flyer did not strongly market the camp and the discount for female students could not be included.



The winter break camp had 37 participants of which 24 were male and 13 were female (65%, 34%). The summer break camps had 21 participants attend both sessions of which 20 were male and 1 was female (95%, 5%). The winter break camp had more participants than the two summer break camps combined and more than twice the percentage of the participants were female in the winter camp compared with the summer camps. The stronger marketing seems to have attracted more students into the winter break camp and the female incentive in the marketing flyer appears to have attracted more female students. There are fewer options for camp opportunities during the winter break, so that may have contributed to the larger registration numbers as well.

The larger number of students in the winter break camp required that the camp activities be offered as multiple class sessions and two additional teacher assistants from Gross High

School helped facilitate the classes. In addition, Gross High School students volunteered to help at the camp and as it turned out the high school students did much of the teaching with the high school teacher assistants handling classroom control and maintaining the daily schedule. The teacher assistants were Mrs. Barbara Anderson-Rogers a physical science and life sciences teacher, and Mrs. Julie McNamara a mathematics teacher. Both teacher assistants were new to teaching robotics and the CEENBoT robotics platform. The winter break camp allowed the teacher assistants to observe how educational robots can be used with students as both the teacher assistants are interested in integrating the robotics platform into their classes.

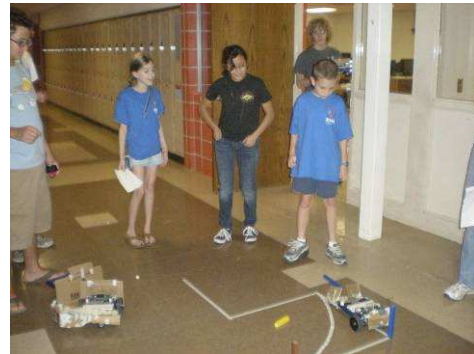

Each day of the winter break camp was divided into two class periods of 1 hour each in the morning, a half hour lunch break, another class period of 1 hour in the afternoon, and a concluding half hour of an Engineering Expo. During the Engineering Expo the participants would demonstrate their last class activity to their family members before leaving the camp for the day. The three classes at the winter break camp were (1) CEENBoT programming using the new graphical programming interface CEENBoT Commander, (2) Basic electricity using Snap Kits and other robots including the iSOBOT, and (3) engineering design where participants built a prototype robot arm from balsa wood and other materials. Smaller groups of about 12 participants would rotate between the classes. Each participant was paired with another participant to make smaller teams within each group. Participants were provided an Engineering Notebook and were encouraged to document their work in the notebook. The notebooks were evaluated by the teacher assistants and the ratings were compiled along with the results of the challenges and the student teams were ranked. Participants were instructed that team rankings would be used to award prizes at the end of the field test.

The CEENBoT programming class used the CEENBoT robotics platform and the new CEENBoT Commander graphical programming interface. The participants were introduced to the programming methods which they applied to a challenge of using the CEENBoT to "plow snow" from a "driveway". The snow consisted of wads of paper and the driveway was a rectangular area taped on the floor. Participants practiced simple programming during the first day and programmed their solution to the challenge on the second day. The programming methods were demonstrated by the high school students and the challenge results, how many wads of paper were removed from the driveway area for each team, were recorded by the teacher assistants.

The basic electricity and other robots class was more exploratory. A high school student demonstrated the use of the Snap Kits and how the iSOBOT can be programmed. Participants seemed to enjoy both activities and the open exploration the activities provided. Both the Snap Kits and the iSOBOT come with instructions and activities that were introduced to the students, and then the participants were allowed to explore on their own. Participants were encouraged to document their activities in their Engineering Notebook and their team effectiveness and documentation was rated by the teacher assistants.

The engineering design class involved a challenge to lift a given amount of weight with a robot arm prototype to be built from balsa wood and other materials. The teacher and students discussed the engineering design process and the goal of the challenge, and then the participants

spent some time planning their design. Participants were encouraged to document their plan in their Engineering Notebook. Participants built and tested their designs and the teams were rated based on the effectiveness of their design and how well they documented their work.

The team rankings were used to award prizes during the Engineering Expo on the second day with the highest ranked teams able to select prizes first from a prize table before the lower ranked teams. The students were reminded during the classes to participate fully and to document their work and that the teams would be ranked for the prize awards. There were prizes for all student teams but some prizes were of higher quality and interest to the students. As it turned out, all the top prizes were won by student teams that included or were entirely made up of female students. It seemed during the activities the female teams would focus more on the goal of the activity where as male teams would do more self directed exploration that may or may not contribute to the activity goal.

The winter break camp was evaluated with the same pre and posttests that were used for the Robotics Expo 2011 that included some demographics information, robotics knowledge, workplace skills, attitudes toward STEM, and interest in future careers. The activities for this field test were not necessarily selected to cover all the topics contained on the knowledge test. The surveys were designed to capture changes in the attitudes and interests of the participants. Survey and test analysis was done only for students that turned in the parent consent form and that took both the pre and post tests. There were 37 participant results included of which 24 were male and 13 were female (65%, 34%). The ethnic and age distributions for the included pre and post tests were 2 Hispanic/Latino, 34 white, 1 multi-racial (5%, 92%, 3%) and 8 at 10 years, 16 at 11 years, 7 at 12 years, 4 at 13 years, and 2 at 14 years (22%, 43%, 19%, 11%, 5%).

On the knowledge test there was a significant increase ($P < .05$) for the number of correct answers from 9.4 to 9.8 points from pretest to post-test on the 18 question test. Test questions relating to computer programming (Q1, Q3, Q15) contributed most to the net average increase (0.24, 0.22, 0.11). The net average increase in ratings describes how much the rating increased averaged over all survey participants. A net average increase of 0.50 means the net average rating increased by 0.50 for the 1 to 5 on the survey, such as from 3.2 to 3.7. Survey items on workplace skills, attitudes toward STEM, and interest in future careers were stated in a positive way so that an increase in score would indicate an improved attitude toward the skill. Each statement was rated on a 5 point scale with 5 indicating strong agreement and 1 indicating strong disagreement. The workplace skills survey questions had average scores that significantly increased ($P < .05$) from 87.7 to 91.8 with questions about using step by step problem solving and working with different people (Q2, Q11) with the highest average net increase (0.51, 0.43) with ability to brainstorm, team contribution, planning, and presentation skills (Q1, Q21, Q3, Q6) also having higher positive average net increase in ratings (0.38, 0.35, 0.32, 0.32). The attitudes towards STEM survey questions had average pretest and post-test scores that did not significantly change (66.9, 66.9), with confidence in programming (Q13, Q15) having the highest average net increase in ratings (0.46, 0.30). The career interest survey questions also had average pretest and post-test scores that did not change (13.4, 13.4).

The summer break camps were split into two sessions and had 12 participants in the first session and 9 participants in the second session. These sessions were small enough so that the students could stay together in a single group. The participants were placed in teams of two participants and each team had one robot to use. Two to three driver controlled activities were done each morning in a science classroom, then after a 30 minute lunch break the participants met in a computer lab to do programming activities with CEENBoT Commander the graphical

programming interface. The summer 2011 field test was facilitated by Mr. Steve Hamersky who did all the teaching and was assisted by 4 to 5 high school students who helped participants work with robots and computers (for programming) and they judged the contests and engineering notebooks.

Activities followed the SPIRIT lesson format with asking, exploring, instructing, organizing, and understanding (AEIOU) components. The activity started with the facilitator asking questions and participants exploring the lesson concepts for a few minutes. Additional instruction was given and participants would organize their thinking and plan for an activity challenge to be completed and used to evaluate the participant understanding. All activities involved a challenge or prepared for a challenge. Participants were aware of the challenges and were aware that the challenge results would be used to rank the teams and that there were prizes for the higher ranked teams. Participants were also encouraged throughout the field test to document their work in their engineering notebook and were told that the notebooks evaluation scores would be included in the team ranking scores.

It had been noticed in other field tests with middle and high school level participants that the current version of the CEENBoT had components that can become damaged. The infrared sensors on the front and the wireless receiver that plugs into the printed circuit board are particularly at risk for damage. In preparation for the summer field test the instructor and the high school student helpers designed and installed shields made from polycarbonate plastic on the front of the CEENBoTs. The shields worked very effectively providing the needed protection yet allowing

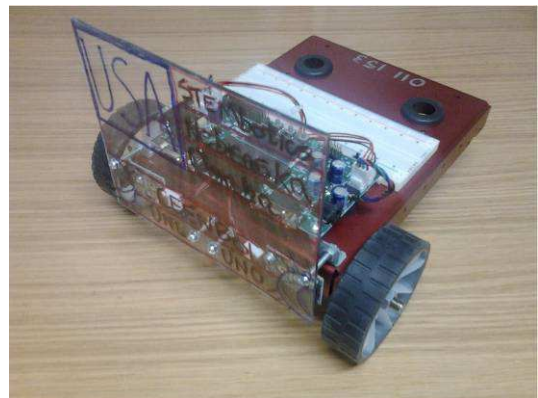

access to the printed circuit board. There were no CEENBoTs damaged during the summer field test due in large part to the protection provided by the polycarbonate plastic shields.

Participants started with an introductory activity about the robot and how to work in lab areas safely. To practice mathematics and driving skills the participants completed a component challenge activity that involved calculating ratios and setting speeds on the robot. A group graphing activity was completed where a group of robots created a linear graph by using different speed settings. Participants then worked on an activity to determine the wheel revolutions required for forward movement and 90 degree turns. This information was used in the next activity where the participants started programming the robots and were challenged to follow a prescribed path. The path involved the forward movement and 90 degree turns that the participants had studied earlier. The morning of the second day participants completed a CEENBoT bump mode challenge activity where they would score points if they could bump off other robots in real time. They had to understand how the bump mode was programmed, how the Infrared sensors worked, and the bump mode program algorithm built into the robot. Participants completed the programming challenge in the afternoon of the second day applying programming ideas such as sequential statements, algorithms, and modular program design.

The summer 2011 field test sessions were evaluated with the same pre and post tests that were used for the Robotics Expo 2011 and the winter 2010 field test. The activities for this field test were not necessarily selected to cover all the topics contained on the knowledge test. Survey and test analysis was done only for participants that turned in the parent consent form and that

took both the pre and post tests for which there were 28 participant results included of which 20 were male and 1 were female (95%, 5%). The ethnic and age distributions for the included pre and post tests were 1 Hispanic/Latino, 19 white, 1 multi-racial (5%, 90%, 5%) and 4 at 11 years, 9 at 12 years, 1 at 13 years, and 7 at 14 years (19%, 43%, 5%, 33%).

On the knowledge test there was a significant ($P < .05$) average increase for the number of correct answers from 10.9 to 11.5 points from pretest to post-test on the 18 question test. Test questions relating to computer programming and robot sensors (Q3, Q4) contributed most to the net average increase (0.39, 0.13). The net average increase in ratings describes how much the rating increased averaged over all survey participants. A net average increase of 0.50 means the net average rating increased by 0.50 for the 1 to 5 on the survey, such as from 3.2 to 3.7. Survey items on workplace skills, attitudes toward STEM, and interest in future careers were again stated in a positive way so that an increase in score would indicate an improved attitude toward the skill. Each statement was rated on a 5 point scale with 5 indicating strong agreement and 1 indicating strong disagreement. The workplace skills survey questions had a significant ($P < .05$) average score increase from 88.4 to 92.9 points with questions about brainstorming, presentation skills, and problem analysis (Q1, Q6, Q19) with the highest average net increased rating (0.50, 0.45, 0.45) with planning, communication, and problem analysis (Q3, Q5, Q9) also having a positive average net increase in ratings (0.41, 0.41, 0.41). The attitudes towards STEM survey questions had a small (not significant) increase in scores (65.2, 65.8), with confidence in programming (Q13, Q15) having the highest net average increase in ratings (0.45, 0.45). Questions about communication and problem analysis (Q6, Q7, Q9) showed a significant ($p < .05$) positive average net increase in ratings (0.23, 0.23, 0.27). The career interest survey questions had a slight but significant ($p < .05$) increase 13.6 to 14.3 in average ratings with scientist (Q1) receiving the highest net average rating (0.41) with engineer (Q2) also having a higher net average rating (0.18).

The 2011 winter and summer field tests held at Gross High School provided valuable insights into the implementation of the AEIOU teaching model, the use of educational robots with middle school level participants, and the use of the CEENBoT robotics platform. The AEIOU teaching model was used as the basis for the development of the field test activities. Each field test seemed to improve in terms of participant involvement and interest, and with the addition of the robot shield and the use of the CEENBoT Commander programming environment the robotics platform proved to be very usable with middle school level participants.

The first step in the AEIOU teaching model is asking questions (A) and instructors in the field test found that asking questions does generate interest in the activity and participants seemed to enjoy sharing ideas. Participants also enjoyed exploring ideas and skills (E) and the individualized one-to-one instruction (I) helped participants begin to apply the ideas and skills to the activity. Participants would organize (O) results as they prepared for the activity challenges. Success in the challenges provided the evaluation of participant understanding (U). The AEIOU teaching model was an effective way to organize the field test activities. Providing many opportunities for participants to communicate may have been the reason pre-test and post-test questions related to communications and teamwork particularly increased in importance to the participants.

Many of the activities used in the 2011 field tests would culminate in a challenge such as setting the proper speed on the robot using proportional thinking, or programming the robot to follow a prescribed path. The challenges were very motivating to the participants and provided



a vehicle for critical and creative thinking and unlimited application of concepts. In activities that did not involve a challenge, participants would quickly finish by getting the "answer" that was the goal of the activity. By using challenges that were carefully constructed to focus on a particular concepts, such as the component challenge which focused on 3-4-5 right triangles and proportional thinking, or the bump mode challenge that focused on computer programming algorithms, or the programming challenge that encouraged the use of

modular programming methods, participants were engaged in improving their understanding up until their challenge time occurred. Student participants seemed to enjoy the challenges and were much more focused on the challenges than they were when exploring ideas or concepts to further their knowledge. The summer field test with smaller group sizes made it easier to effectively implement the challenges that were more motivating to students than exploration activities. This may have contributed to an increase in attitudes toward science and engineering during the summer field test as compared with the winter field test.

The CEENBoT Commander integrated development environment for programming the CEENBoT robotics platform proved to be very effective at the middle school level. Participants in the field test were very quickly able to learn how to create programming projects and how to use the drag-and-drop methods to build specific programs. Downloading the programs into the robotics platform was also easily mastered as the students would modify and update their programs many times in preparation for the programming challenge. The pre-test and post-test results showed students improved their understanding and attitudes toward programming and their ability to program and troubleshoot robotic programs, which may be due to the participant success with the CEENBoT Commander integrated development environment.

In summary, the 2011 field tests provided many useful results and insights, but in future there may need to be more mathematics activities included that illustrate what mathematicians do in their careers and how theories from mathematicians are used by scientists and engineers specifically applied to robotics. Improving attitudes toward mathematics is very important as it serves as a doorway to other areas such as science, technology, and engineering. Marketing the winter robotics camp specifically to females helped encourage more females to attend and those attending females received encouragement to pursue careers in STEM areas. The CEENBoT robotics platform performed very well especially with the addition of the shield to protect the exposed components. Since all components and electronic circuits of the robotics platform are accessible, participants can explore all aspects of the robot design and operation.



Virtual CEENBoT Collaboration with 4-H Robotics:

As mentioned in the activities section, the SPIRIT project worked closely with the 4-H organization, Dr. Gibson from Global Challenge and Dr. Barker and a leadership team from the University of Nebraska-Lincoln, to contribute to an online virtual CEENBoT program, that is a robotics simulation that will be distributed to 4-H clubs and camps. The Virtual Robotics application is a multi-platform software program that has been developed to give students a general introduction to robotics. The application was developed as an educational game in which students work in a virtual laboratory to investigate the nature of robotics and then build and test a virtual CEENBoT. The students are guided in this process by completing a series of levels that get more challenging. Students must also record observations, their own designs and experiment results in a notebook.



The virtual robotics application was field tested during the Summer of 2010, and the results were encouraging. This field test used an open-ended content questionnaire that youth participating in the field test took before and after the field test experience. Eight youths were available to use all of the program features for a duration of 3 days, and to work through all of the virtual CEENBoT activities. The questions examined selected “big ideas” within the context of STEM learning and educational robotics, since that was the focus of the virtual robotics program. Questions were purposively structured to be direct and simple, to help to elicit a variety of responses from students. In particular, the content instrument asked the following seven questions.



The virtual robotics application was field tested during the Summer of 2010, and the results were encouraging. This field test used an open-ended content questionnaire that youth participating in the field test took before and after the field test experience. Eight youths were available to use all of the program features for a duration of 3 days, and to work through all of the virtual CEENBoT activities. The questions examined selected “big ideas” within the context of STEM learning and educational robotics, since that was the focus of the virtual robotics program. Questions were purposively structured to be direct and simple, to help to elicit a variety of responses from students. In particular, the content instrument asked the following seven questions.

- 1) What is a robot?
- 2) What is a variable?
- 3) What is the engineering design process?
- 4) What is a computer program?
- 5) What is science?
- 6) What is mathematics?
- 7) How are robots used in real life?

Youth responses to the questions were then typed up for each individual youth and analyzed by a research team from the University of Nebraska at Omaha College of Education. Responses were typed such that they had a student’s pretest and posttest response shown side by side within a word document. Responses were then scored on whether they illustrated a deeper understanding from the pretest to posttest.

| Instrument Question | Improved (N) |
|--|---------------------|
| 1. What is a robot? | 50.0% (4) |
| 2. What is a variable? | 12.5% (1) |
| 3. What is the engineering design process? | 50.0% (4) |
| 4. What is a computer program? | 12.5% (1) |
| 5. What is science? | 50.0% (4) |
| 6. What is mathematics? | 25.0% (2) |
| 7. How are robots used in real life? | 50.0% (4) |

It is interesting to note that across the use of the virtual CEENBoT program, four of the content questions surfaced as particularly illustrative of some growth within the big ideas targeted by the program. These included “What is a robot?”, “What is the engineering design process?”, “What is Science?” and “How are robots used in real life?”. For these questions in particular, students provided more detailed and meaningful responses on the posttest instrument. An example response to each of the seven questions, illustrative of a deeper understanding for that topic now follows.



- 1) What is a robot?

Pretest Example: “Not sure.”

Posttest Example: “A robot is a machine that can operate without people.”

- 2) What is a variable?

Pretest Example: “I don’t know.”

Posttest Example: “The part of an experiment that can be changed.”

- 3) What is the engineering design process?

Pretest Example: “I have no clue.”

Posttest Example: “The engineering design process is the process of designing something, revising the design, and testing it.”

- 4) What is a computer program?

Pretest Example: “A computer program is a program on a computer”.

Posttest Example: “A program written that helps the computer data chip work.”

- 5) What is science?

Pretest Example: “I am not sure”

Posttest Example: “Science is the study of different things, such as robotics, nature, space, rocks, etc.”

6) What is mathematics?

Pretest Example: “Problems, addition, subtraction, multiplication, division”.

Posttest Example: “A math science used to find answers”

7) How are robots used in real life?

Pretest Example: “Machines are robots.”

Posttest Example: “In the real life, robots are used to help people do things. Robots can rescue people, put out fires, and help out at home.”

Pilot test data for the evolution of the Virtual CEENBoT program has been relatively extensive, and has included 62 facilitator reviews from 35 reviewers and 640 youth reviews (estimated at about 500 different children) that have provided feedback on individual modules as they were taught within a draft version. Both the youth and facilitators alike provided reflective feedback about the instructional aspects of the applications. Both groups also answered Likert scale questions related to the complete instructional environment represented by the virtual modules. The Likert scaled items were then summarized for each individual module, and for the draft curriculum as a whole. Here we report on several of the summary findings.

Four questions asked of both adults and students were whether the activity helped them learn science, technology, engineering and mathematics (STEM). Two additional questions asked if they found the learning experience “interesting” and if they would tell their friends that it was a good thing to do. That last question was modified for the adult to ask if they thought students found the experience engaging, which is a key consideration in any online environment. The results were similar across three of the four STEM concept areas (STM), and those results contrasted with the results for the fourth area, engineering (E), possibly indicating that students have less ability to recognize when they are learning engineering in this context.

Similar to the findings for learning engineering concepts, a large majority of adults (over 90%) and less, but still a strong majority of students (over 70%) differed in whether youth would find it interesting; adults somewhat overestimating the potential interest level compared to the students. However, with 74% of students finding it interesting,

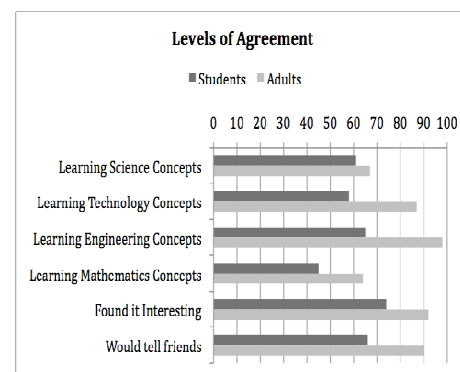
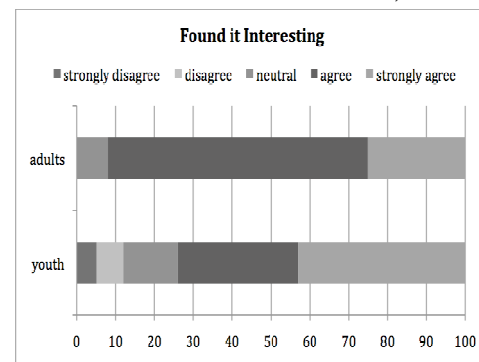
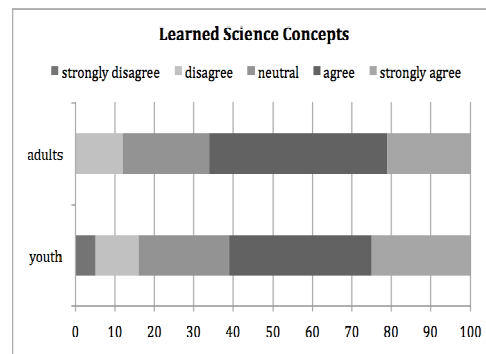

the design teams were encouraged.

Comparing results across all feedback measures shows that student results were consistent on across all questions, with between 12% and 26% disagreeing with each proposition (e.g. that STEM learning had occurred) and between 14% and 23% remaining neutral. The range of agreement and strong agreement in the students ran from a low of 45% on learning mathematics to a high of 74% finding the program interesting. In the adult data, the range of agreement and strong agreement had a low 64% on whether mathematics concepts were learned to a high of 98% agreeing that engineering concepts had been learned.

In addition to the quantitative results, specific suggestions were solicited, which were then organized by the project leaders and shared with the design teams. Suggestions for Virtual Robotics led to revisions:

- Changed how participating youth navigate through activities, requiring that they begin each activity before they are able to go to the virtual test area, as recommended by the expert reviewers.
- Graphical changes were introduced to make the environment seem more sophisticated and to better appeal to middle-school age youth
- Created “books” within the program with interesting graphical designs to engage youth with the background information needed in the program
- Supporting collaborative inquiry within the activities and working with youth in small groups and teams
- Supporting youth-adult partnerships as adults mentor youth in leading the curriculum
- Support and suggestions for leaders in using the curriculum in different contexts and across different age groups

Students using the Virtual CEENBoT program were also given an attitude questionnaire. As described more fully in other parts of this report, the attitude instrument was a short 33 question Likert-scaled instrument that asked youth their attitudes about mathematics, science, and learning. This assessment has been previously used and validated within a variety of educational settings, summer camps, and after-school programs including previous work within 4-H (Barker, Nugent, Grandgenett, Hampton, 2008). In general, although the students generally scored high in their attitudes as measured by this instrument, there was not a statistically significant improvement in attitude by youth as measured by the overall instrument. This is somewhat explainable by the fact that most of the participating youth who enrolled in the summer field test started out relatively high on the attitude instrument, and then also scored as generally high on the instrument posttest.

However, although the overall attitude questionnaire results across tracks did not show a significant difference overall between the pretest and posttest administration, three selected individual questions did show some significant improvement within the context of an exploratory field-test environment (using the exploration level for significance of $p < .10$). While statistical validity of the instrument for individual questions has not been fully established, these individual results were encouraging, and illustrate that youth may well have improved their attitudes for some elements of the use of robotics and technologies within the field-testing setting.

Questions Showing Exploration Level Improvement ($p < .10$)

Q2: It is important for me to learn about robotics.

(Pre = 4.21, Post = 4.52; $t=1.498$, $p < .071$)

Q13: I like using the scientific method to solve problems.

(Pre = 3.60, Post = 3.87; $t=1.298$, $p < .097$)

Q23: I can fix a program for a robot that does not behave as expected.

(Pre = 3.83, Post = 4.16; $t=1.652$, $p < .052$)

Field Test Study of the CEENBoT in Undergraduate Coursework

Although the SPIRIT Project is primarily focused on middle school, it is also striving to connect the use of the CEENBoT platform, and curriculum strategies, so that it is a seamless environment between middle school, high school, and undergraduate STEM education. Since the CEENBot platform, as developed in SPIRIT, is striving to be a true computer and electronics engineering platform, it was thought that it would be important to also confirm its utility at the undergraduate engineering level. Toward this end, Alisa Gilmore and Herb Detloff, senior personnel in SPIRIT and instructors in the undergraduate CEEN program (Computers and Electronic Engineering), did a study during 2011 with undergraduates using the CEENBoT in a Senior class, who had used the CEENBoT within their program, to retrieve their reflections on its utility for their undergraduate engineering program.

The study in CEEN attempted to determine if specific skills, capabilities and self-efficacies were enhanced in the students having hands-on control and programming experiences with the CEENBoT platform. The tools implemented included a pre and post student survey and a focus group session with these seniors. The focus group was conducted by two college of education professors.

The pre and post survey results revealed an increase in the students' perceived technical abilities and measures of self-efficacy in the overall group of seniors at the end of the semester. Several of the questions had encouraging results, and represented 27 seniors. These included: How do you rate your confidence to program an autonomous robot? (Pre: 42.8% Post: 55.50%); How do you rate your confidence to diagnose a problem with a programmable electronics or computer device? (Pre: 57.1% Post: 85.2%); How do you rate your confidence to trouble-shoot a programmable electronics or computer device? (Pre: 57.1% Post: 85.2%); How would you rate your confidence to resolve and repair a diagnosed problem with programmable electronics or computer device. (Pre: 71.4% Post: 85.2%).

Comments from the focus group observation summary prepared by Dr. Grandgenett revealed the pros of using the CEENBoT voiced by students. Their comments included the following, using the stem of The CEENBoT is: "Perhaps the only avenue for the current CEEN student to truly put what they learn into practice; "Easier to get behind a project that is so easy to show students results"; "Has the ability to add on more features"; "Is an interesting and realistic connection to robotics"; "Has the ability to get started quickly at a low level, but can

still be taken a long way by more advanced students.”

Students recognized that the platform was recently modified for the course, and felt that the newness of the CEENBoT made it a challenge for this iteration of the course. Even with these challenges, students felt that “the CEENBoT was still a very useful platform for CEEN learning, and was superior in potential use to the TekBot, and worthy of continued use and refinement for CEEN instruction.”

Student feedback from the focus group session provided many constructive insights for the further integration of the CEENBoT. These included suggestions for instructional refinements for achieving a cohesive integration of the platform across the CEEN program. Students suggested the need for a dedicated laboratory structure for this class, the need to expand upon and refine laboratory instruction, the need to achieve a steady-state in platform development, and the need to separate the course into two separate courses to allow for a dedicated course in mobile robotics. They also recommended that the integration of the CEENBoT into the 4-year CEEN sequence continue to be developed and coordinated between instructors.

The CEEN study provided important data from student feedback that will be applied to further refinements of assessment tools of student learning, and ultimately to an informed and effective integration of the CEENBoT in the 4-year ECE sequence. In the context of the SPIRIT program, it also provided a confirmation that a platform that is being used and modified for K12 education, can continue to be useful in undergraduate STEM education.

Artwork Added to the Curriculum:

Feedback results from teachers and students in the initial pilot testing process had also suggested that we add more “fun and engaging” visuals to the lessons and curriculum activities. The project thus found a professional graphics design artist from a local television station that was very interested in working (inexpensively) to add some interesting “cartoons illustrations” to various lessons. As part of the lesson writing process, the SPIRIT lesson writers now include an idea for a cartoon that illustrates a STEM concept in their lesson. This illustration idea is then noted at the start of the draft lesson and labeled “Cartoon Idea.” with the illustration to be

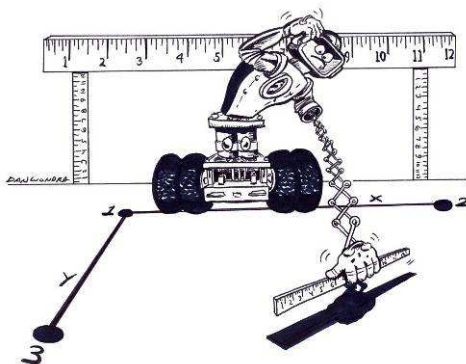

added at a future date. To illustrate the lesson, Mr.

Dan Wondra, an Omaha-based graphic designer at a local television station, then creates the cartoons needed. His work is both creative and impressive with some excellent and thoughtful illustrations of STEM concepts, in a kind of “editorial cartoon” style.

The cartoons include a personable CEENBoT that is sometimes illustrated as a female robot, and sometimes



illustrated as a male robot. The cartoons are also designed to give the reader a clever and engaging visual “hint” about the STEM concept for the lesson. Humor is also provided and integrated into the cartoon visuals. Teachers and students replying to lesson feedback forms, as well as in anecdotal comments, have really embraced the cartoon illustrations, and the initial feedback in the pilot sessions has been very positive about this element when it is included. In addition to creating the cartoons for the lessons, Mr. Wondra has also created the designs for the t-shirts as part of the CEENBoT Showcase events, making his contributions truly an integral part of the SPIRIT project and its evolving curriculum components. More than 70 different cartoons are available to teachers, each with an instructional context. A selection of these cartoons are available free at: <http://www.ceen.unl.edu/TekBots/SPIRIT2/Multimedia/>.

SPIRIT 2009, 2010, and 2011 CEENBoT Showcase Events:

In support of further partnerships with area school districts, businesses, and other partners that are so critical to helping us to refine the SPIRIT curriculum and the CEENBoT platform, the project held a showcase event on March 28th of 2009 and a second showcase event on January 30th, 2010, and a third on February 19th, 2011. A total of 113 students from grades K-12 attended the first event along with teachers and many parents. A total of 26 schools (and 34 teachers) were represented in this inaugural event. The second event had more than 400 students participate and was held at the Strategic Air and Space Museum in Ashland, Nebraska. The third event had more than 500 students participate. The Governor of Nebraska gave the opening welcome speech during 2010 and 2011. Students in all three showcase events participated in various robot challenges and made presentations related to robotics, and provided ideas on how they could extend or use the CEENBoT. Teachers also presented on how educational robotics overlapped with their current curriculum goals and where such activities might further assist with student STEM



Nebraska Governor Dave Heineman gives the opening

achievement. There was news coverage by television stations and state newspapers at each of the 2009, 2010 and 2011 events. Some sponsors from business also contributed prizes to students at each showcase event. Business partners included Lockheed Martin, Union Pacific, Omaha Public Power District, and Cox Communications. College students from both the University of Nebraska at Lincoln engineering programs and the University of Nebraska at Omaha College of Education programs helped to run the two events. All student participants in the Expo received t-shirts and a robotic bug donated by the Nebraska NASA Space Grant, and many schools received a CEENBoT kit and an Electronic Snap Circuit Kit that was also donated.



Students take turns with Jason Harper's "Mars Volta" remote

The second CEENBoT Showcase event on January 30th, 2010 and the third Showcase event on February 19th, 2011, were both particularly well attended. These two most recent showcases were a statewide event, and we partnered with the 4-H Robotics Project on both of them. The second and third event was called the Nebraska Robotics Expo, and will eventually become a regional, and then a national event. We have developed strong collaborative

partnerships in support of this large-scale and now annual effort, that includes the Boys and Girls Clubs Inc., the University of Nebraska System, the Peter Kiewit Institute, the Strategic Air and Space Museum, the Nebraska 4-H, and the NASA Nebraska Space Grant. The further events will feature a CEENBoT showcase program on the SPIRIT side as well as a FIRST LEGO League qualifying competition on the 4-H Robotics Project side. Working closely with the 4-H Robotics Project on the Robotics Expo, we also examined student STEM concepts, attitudes and workplace skills using surveys described earlier. Samples of these surveys are also available in the appendix.

As measured by dependent “t” tests, CEENBoT participants in the Robotics Expo have shown significant increases in the engineering scale of the cognitive test, although the overall test statistic was not significant. For the attitude measure, participants had significantly increased ratings for the task value of science and problem approach scales. There were also some limited increases (not significant) in overall attitude, task value of math, and robotics self-efficacy.

The workplace measure tapped 21st Century Skills. The overall increase in this measure was significant, as well as the problem approach. The table below shows the 2010 pre- and post mean scores as an example for the overall cognitive test scores and its subscales, as well as the attitude and workplace measures and their subscales.



Many middle/high school students, teachers, and parents attended this Saturday.

| Pre-post Means and <i>t</i> Statistics for Cognitive Attitude, and Workplace Measures | | | | | |
|--|----------|-----------|----------|-----------|-------------------|
| Cognitive Test | | | | | |
| | Pre Mean | Post Mean | <i>t</i> | <i>df</i> | <i>p</i> (1-tail) |
| Overall Cog | 10.96 | 10.89 | .24 | 73 | .40 |
| Engineering* | 3.38 | 3.66 | 2.29 | 73 | .02 |
| Programming | 4.79 | 4.59 | 1.02 | 73 | .16 |
| Eng. Design | 2.78 | 2.64 | 1.10 | 73 | .14 |
| Attitude Measure | | | | | |
| | Pre Mean | Post Mean | <i>t</i> | <i>df</i> | <i>p</i> |
| Overall Att. | 4.19 | 4.21 | .83 | 74 | .21 |
| Task Val Sci* | 4.21 | 4.31 | 2.18 | 74 | .02 |
| Task Val. Math | 4.29 | 4.35 | 1.03 | 74 | .16 |
| Task Val. Rob. | 4.43 | 4.28 | 2.33 | 74 | .02 |
| Problem* | 3.98 | 4.14 | 2.45 | 74 | .02 |
| Self Eff. Robot | 3.84 | 3.90 | .73 | .74 | .24 |
| Team | 4.43 | 4.35 | 1.03 | 74 | .15 |
| Workplace measure | | | | | |
| | Pre Mean | Post Mean | <i>t</i> | <i>df</i> | <i>p</i> |
| Overall** | 4.29 | 4.41 | 2.97 | 59 | .002 |
| Problem*** | 4.03 | 4.30 | 4.24 | 59 | .001 |
| Team | 4.40 | 4.39 | .31 | 59 | .38 |

Overall, we fully expect to continue to utilize these sorts of showcase events, and to steadily expand them, as a way for teachers to share their classroom strategies and materials related to SPIRIT, and as a way for their students to get further excited about educational robotics. The next events in 2012, also to be held at the Nebraska Strategic Air and Space Museum, will include events that involve the TI Graphing Calculators and a functional

Graphing Programming Interface. Additional partner organizations and exhibitors will be sought, such as the University of Nebraska Medical Center, who contributed a robotics surgery simulation for the each of the events. These showcase events also provide a nice catalyst to further partnerships, and a provide a convenient way to engage with industry partners to enhance their collaboration, as well as to increase their understanding of what teachers and schools are trying to accomplish within the SPIRIT project and STEM education. We hope to eventually make this annual showcase event a truly national event. We believe that it can enrich both our partnerships, and our SPIRIT curriculum, by bringing even more teachers, schools, partners and creative energy into the SPIRIT project.



UNMC Surgical Robotics Demonstration fascinates students

Student Participation in Robotics Construction:

Since one of the goals of the project related to the newer CEENBoT platform is to develop a more compatible robot for student construction, students have been regularly invited to build the CEENBoT at either their schools, or at summer and Saturday sessions at the Peter Kiewit Institute. In many ways, these student-constructions have been technical "dry runs" to see if middle and high school students can successfully construct the robot, and if they needed additional assistance within that process. The CEENBoT and its various versions have now had more than 200 students build the robot in these various settings. The students sometimes build the robot right along with the teachers. In fact, anecdotal observations have indicated that students were even a bit faster with the robot construction than teachers. This was an encouraging observation, as well as a useful editing contribution, since the students also found several edits to the construction directions that the teachers and consultants had missed.

Several schools have already embraced CEENBoT construction and have integrated into the curriculum. For example, at Westside Middle School, the introduction of robotics into the curriculum begins with students observing the robot's motion as it is in bump-bot mode. Then questions are asked, such as, "How does the robot know to make the decisions it does?" This leads us into a discussion about programming. After the introduction, students study the engineering design process as they build the robots and program them to solve a problem. For efficiency, the Westside robots are stored in a "parking garage" and fueled at "charging stations."



To further study the design process, as well as to protect the wires and components, Westside also designed a cover to go over the circuit board. Not wanting to discourage curiosity or block the view of the digital display, the cover will be made for the school with clear acrylic, approximately 1/8" thick. The cover is removable, allowing for future expansion of end-of-arm-tooling, repair, and upgrades. Openings also allow for charging, turning on and off, resetting, and access to ports. Currently, Westside students are testing their design with cardstock prototypes. After feedback from observation and students, the covers will be manufactured at a local plastic fabricator for the school's use, illustrating the utility of an open source CEENBoT in supporting student creativity and engagement with the CEENBoT.



3. Describe the opportunities for training and development provided by your project:

Continuing into 2012 and over the duration of funding to date, the SPIRIT project team has had a great opportunity to engage in very collaborative teacher professional development on educational robotics. The engineering experts have worked closely with education and curriculum experts in their technical instruction, and in turn, the educational experts have coordinated closely with engineers in their pedagogical instruction. The result has been an excellent group synergy and set of teacher training activities, where the exchange of ideas, suggestions, and formative review has systematically continued on both the technical and educational objectives. This has resulted in a natural and ongoing professional development process for both the engineering/technical team members and the education team members that have directly supported the SPIRIT curriculum development process, as well as the further development of the CEENBoT platform itself.

The SPIRIT project has also continued to refine the professional development efforts for area middle school teachers and a total of 305 teachers have now participated in extended training of multiple day workshops, from 3 to 10 days (or more). We have also engaged in shorter duration sessions (of several hours or a day), at the request of various school districts as well as provided one-half day awareness workshops for teachers and students related to how educational robotics can help to teach STEM concepts. Most of the recent teacher training workshops, were completed at no cost to NSF, with the school districts or other organizations, such as Dream It Do It, raising the money for the needed teacher training activities. More than 700 teachers have also participated in shorter duration training events, again, at little or no cost to NSF. These participating teachers are now providing an excellent source of the pilot testing

of individual SPIRIT lessons (already underway), and may contribute to more extensive field-testing to be undertaken in 2012.

All project training included having teacher participants systematically look at their local curricula and the national, state, and district standards to determine the best integration or “touch points” for new robotics activities in their specific coursework. The project website contains several resource documents for each teacher in this endeavor, such as standards lists, integration suggestions, videoclips, student assessments, samples of student STEM content misconceptions, and a variety of other curriculum support documents, such as a spreadsheet of potential curriculum "touch points" for integration into various school curriculums.

4. Describe the outreach activities your project has undertaken:

As we continue into 2012 with the SPIRIT project and its curriculum development efforts, as well as the teacher professional development, the outreach and teacher engagement has been critical to the our overall project success as we have worked systematically to integrate teacher training, curriculum development, pilot testing, field testing, and curriculum refinement activities. Faculty and staff from the College of Education have frequently observed and videotaped SPIRIT lessons in action, and have worked closely with teachers who are piloting and field-testing testing lessons, and who have agreed to work with us in a variety of curriculum development endeavors. Engineering students and faculty from Peter Kiewit Institute have also been routinely invited to come to the schools to observe and participate in the CEENBoT construction activities. Outreach activities have also included local science and engineering fairs and as well as the now annual SPIRIT Showcase, in which SPIRIT teachers and their students participate in various collaborative and competitive activities, and give presentations on their efforts (see pictures and overview in the report Appendix).

The Omaha Public Schools and the Metropolitan Omaha Education Consortium (13 area school districts) have indicated that the SPIRIT efforts dovetail very well with the existing science and mathematics curriculum in these schools. Special attention has been paid by this initiative to aligning with the national science, mathematics, and technology standards, since these standards have been of particular interest to STEM educators, and form a foundation to the evolving SPIRIT curriculum. Many area teachers and administrators have sent thank-you notes that praise that the design and format of the teacher training efforts and outreach, as well as the SPIRIT lessons and its evolving cyberinfrastructure. SPIRIT teachers are also continuing to write STEM lessons and to contribute STEM lesson ideas based upon educational robotics, which integrate various skills and knowledge gained from their previous SPIRIT training activities, and that align with their own district's vision for innovative and engaging STEM learning for all students. We have also included various other lessons that look at the context of STEM education within energy, mechatronics, industrial automation, and other similar topics that overlap nicely with educational robotics.

The SPIRIT project is also undertaking national level workshops at professional conferences, including the High Impact Technology Exchange Conference and the International Technology and Engineering Educators Association Conference, as well as conducting presentation sessions at conferences such as the Society for Information Technology and Teacher Education, the National Science Teachers Association Conference, and the National Council of Teachers of Mathematics conference. These workshops and conference presentations have undertaken during the duration of the grant, but have significantly expanded in 2011 and are planned to expand even further in 2012.

The SPIRIT project has also begun a systematic outreach to various educational service units in the area, which are support consortiums for area school districts. Four educational service units (located in Kearney, Beatrice, Omaha, and Millard) have already requested to host awareness and exploration sessions for their teachers, to participate in pilot testing efforts, and have also agreed to provide control group data from some of their students in the area, as well as to help to retrieve perceptions data from students participating in the awareness sessions. Potential field test collaborations are also developing well. Other educational service units in Nebraska, as well as several Area Education Agencies in Iowa have also indicated an interest to work with us in the future, particularly within the context of pilot testing and field-testing. In addition, four community colleges: Central Community College in Columbus, Nebraska; Western Nebraska Community College in Scottsbluff, Nebraska; Iowa Western Community College in Council Bluffs Iowa; and Northeast Nebraska Community College in Norfolk, Nebraska have all worked initially with the SPIRIT project to host a SPIRIT training or awareness session. This evolving link to community colleges is a new and exciting outreach partnership that we see as having significant potential to help with systematic SPIRIT growth and sustainability.

There is also a growing interest by university Electrical and Computer Engineering (ECE) departments in the use of the CEENBoT as an educational platform that promises to invigorate our existing programs and to again help to support SPIRIT sustainability. This will eventually help to form partnerships around the country where university ECE departments and local K12 schools work together to use and extend the SPIRIT robotics curriculum. Several university partnerships are already underway. For example, Tulsa University's ECE department has had positive experiences with robots in the past and is now very interested in the possible adoption of the CEENBoT to fit the needs of their university-level ECE department. Rose-Hulman Institute of Technology (one of the most progressive ECE departments in the United States) is another example and is interested in reviewing the attributes of the CEENBoT in comparison to other platforms currently used in their program. The Missouri School of Science and Technology's ECE department (formerly the University of Missouri-Rolla) also has an interest in providing the educational robotics platform to their entering freshman class in a manner similar to what the University of Nebraska is doing here in Omaha at the Peter Kiewit Institute. Finally, Howard University's ECE chairperson sees the CEENBoT as a means to reach out to their minority students by penetrating the local K-12 environment surrounding Howard University in Washington D.C. In further support of extended university collaborations, the national ECE chairs group has also suggested that the SPIRIT project promote the CEENBoT and its applications at the annual meeting gatherings. Dr. Chen (SPIRIT Project PI) was recently elected as the president of the Electrical and Computer Engineering Department Heads Association (ECEDHA) for 2012. Two of his projected themes are to increase student diversity by an all out national penetration into the K-12 environment and an increasing voice within education and working with the political leaders of the U.S. to support K-16 STEM education in a focused manner. This leadership position provides a great opportunity to further extend the SPIRIT project into a truly national presence.

Publications and Products

1. Journal manuscripts and other publications

The following publications have been related to activities associated with the SPIRIT project, or are derived from foundational research efforts. Some publications were undertaken in collaboration with the 4-H Robotics and GIS/GPS (GearTech 21) project or with researchers working on teacher education related Technological Pedagogical Content Knowledge, at the College of William and Mary. Additional publications are in the planning process, and will be submitted soon.

Barker B., Nugent, G., Grandgenett, N., Adamchuk S. (2011-In Press) *Educational Robotics in K-12 Education*. Book publication by IGI Global: Hershey, PA.

Grandgenett, N.F., Harris, J., Hofer, M. (2011). An Activity-Based Approach to Technology Integration in the Mathematics Classroom. *Journal of Mathematics Education Leadership*, Fall/Winter 2010-11, which is a journal of the National Council of Supervisors of Mathematics.

Grandgenett, N., Ostler, E., Topp, N., Goeman, R. (2011). Robotics and Problem-Based Learning in STEM Formal Educational Environments. In Barker B., Nugent, G., Grandgenett, N., Adamchuk S. (Editors) *Educational Robotics in K-12 Education*. IGI Global: Hershey, PA.

Rech, J., Matthews, M., Grandgenett, N. (2010). The impact of content courses on pre-service elementary teachers' mathematical content knowledge. *Issues in Undergraduate Mathematics Preparation of School Teachers: The Journal (Content)*, Volume 1, December 2010. Available online at: www.k-12prep.math.ttu.edu.

Topp, N., Ostler, E. O., Grandgenett, N.F., (2011). Contributing to the Cyberinfrastructure: An interactive STEM Lesson Development Model for Educational Robotics. Published in the *Proceedings of the 2011 Society for Information Technology in Education*, Nashville, Tennessee, March 8-11, 2011.

Davidchik, D., Grandgenett, N., Pauley, D. (2011). Business collaboration and blended learning to develop student critical thinking skills. Published in the proceedings of New Learning Technologies 2011 SALT Conference, February 23-25, Orlando, Florida.

Harris, J., Grandgenett, N., & Hofer, M. (2010). Testing a TPACK-based technology integration assessment rubric. In C. D. Maddux (Ed.). *Research highlights in technology and teacher education 2010* (p. 323-331). Chesapeake, VA: Society for Information Technology & Teacher Education (SITE). Available: <http://activitytypes.wmwikis.net/Presentations>

Barker, B., Grandgenett, N., Nugent, G., Adamchuk, V. (2010). Pairing educational robotics with geospatial technologies in informal learning environments. *Journal of Youth Development*, 5(2), 37-42.

- Nugent, G., Barker, B., Grandgenett, N., Adamchuk, V. (2010). Impact of robotics and geospatial technology interventions on youth STEM learning and attitudes. *Journal of Research on Technology Education*, 42, 391-408.
- Barker, B., Grandgenett, N., Nugent, G., Adamchuk, V. (2010). The short-term benefits of educational robotics when paired with geospatial technologies in informal learning environments. In: *Proceedings of the 2010 2nd Annual Computer Supported Education (CSEDU)*, 2, 391-404.
- Barker, B., Grandgenett, N., Nugent, N., Adamchuk, V. (2010). Robots, GPS/GIS, and Programming Technologies: The Power of "Digital Manipulatives" in Youth Extension Experiences. *Journal of Extension* [On-line], 45(5) Article 1FEA7. Available at: <http://www.joe.org/joe/2010february/a7.php>.
- Nugent, G., Grandgenett, N., Barker, B., Adamchuk, V. (2010). The Impact of Robotics and Geospatial Instruction on Student STEM attitudes. *Paper presented at the 2010 AERA Annual Meeting*. Denver, CO. May 3rd.
- Harris, J.B., Hofer M., Grandgenett, N.F, Blanchard, M., Schmidt, D., Young, C. (2010). Instructional Planning Using Curriculum-Based Activity Type Taxonomies. *Journal of Technology and Teacher Education*, Spring, 2010.
- Harris, J., Hofer M., Grandgenett, N.F. (2010). Testing a TPACK-based technology integration assessment rubric. Published in the *Proceedings of the 2010 Society for Information Technology in Education*, San Diego, California, March 29, 2010.
- Grandgenett, N. F., Harris, J., Hofer, M. (2009). Grounded technology integration in mathematics. *Learning and Leading with Technology*, 37(3), pp. 24-26, November, 2009.
- Gilmore, A., Sash, R., Grandgenett, N., Chen, B. (2009). Using robotics to equip K12 teachers: The Silicon Prairie Initiative for Robotics in Information Technology (SPIRIT). Published in the *Proceedings of the 2009 American Society of Engineering Education Annual Conference*, Austin, Texas, June, 2009.
- Adamchuk, V.G., Nugent, B. Barker, and N. Grandgenett (2009). The use of robotics, GPS and GIS technologies to encourage STEM-oriented learning in youth. *Proceedings of the 2009 Midwest Section Conference of the American Society for Engineering Education*, in Lincoln, Nebraska, 16-18 September 2009, D. Schulte, ed. Washington, DC: ASEE.
- Barker, B., Grandgenett, N., Nugent, G., Adamchuk, V.G. (2009). Scaling-up an educational robotics intervention for informal learning environments. Published in the *Proceedings of The World Conference on Educational Multimedia, Hypermedia & Telecommunications 2009*, pp. 3231-3236, Chesapeake, VA: AACE.
- Barker, B., Nugent, G., Grandgenett, N., Adamchuk, V.G. (2009). Synchronous educational robotics intervention for informal learning environments. Published in the *proceedings of*

The World Conference on Educational Multimedia, Hypermedia & Telecommunications 2009, pp. 3237-3242, Chesapeake, VA: AACE.

- Nugent, G., Barker, B., Toland, M., Grandgenett, N., Hampton, A. & Adamchuk V. (2009). Measuring the impact of robotics and geospatial technologies on youth science, technology, engineering, and mathematics attitudes. Published in the *Proceedings of the World Conference on Educational Multimedia, Hypermedia, and Telecommunications* (pp. 3331-3340). Chesapeake, VA: Association for the Advancement of Computing in Education
- Barker, B., Grandgenett, N. & Nugent, G. (2009). A new model of 4-H volunteer development in science, engineering, and technology programs. *Journal of Extension*. [On-line], 47(2) Article 2IAW4. Available at <http://www.joe.org/joe/2009april/iw4.php>.
- Nugent, G., Barker, B., Grandgenett, N. & Adamchuk, V. (2009). The use of digital manipulatives in K-12: Robotics, GPS/GIS and programming. *In the Proceedings of Frontiers in Education's 39th Annual Conference, 2009, FIE '09*.
- Ostler, E., Goeman, B., Grandgenett, N., Wolfe, J.B. (2009). From robotics to semiotics: Using robots and graphing calculators to provide context for traditional algebra skills. *Published in the proceedings of The Society for Information Technology and Teacher Education (SITE) annual conference, March 2-6, Charleston, South Carolina*.
- Grandgenett, N.F. (2008). Perhaps a matter of imagination: TPACK in mathematics education. Published as Chapter 6 in *The Handbook of Technological Pedagogical Content Knowledge for Teaching for Educators*, Matt Koehler & Punya Mishra, Editors. An American Association of Colleges for Teacher Education (AACTE) publication, New York, New York: Routledge Publishing.
- Barker, B.S., Nugent, G., Grandgenett, N.F., Hampton, A. (2008). Examining Robotics in the Learning of Science, Engineering and Technology Topics and the Related Student Attitudes. *Journal for Youth Development: Bridging Research and Practice*, Volume 2, Number 3, online at http://www.nae4-Ha.org/directory/jyd/jyd_article.aspx?id=f5a34e58-1cd3-4994-981d-b81fa406cd74.
- Barker, B.S., Nugent, G., Grandgenett, N.F. (2008). Examining 4-H Robotics and Geospatial Technologies in the Learning of Science, Technology, Engineering, and Mathematics Topics. Publication in the *Journal of Extension*, Volume 46, Number 3, online at <http://www.joe.org/joe/2008june/rb7.shtml>.
- Nugent, G., Barker, B., & Grandgenett, N. (2008). The effect of 4-H robotics and geospatial technologies on science, technology, engineering, and mathematics learning and attitudes. *In Proceedings of World Conference on Educational Multimedia, Hypermedia, and Telecommunications, 2008*, (pp. 447-452). Chesapeake, VA: AACE.

2. Products of the SPIRIT grant

The products related to the SPIRIT project are directly related to the foundational curriculum elements developed by the project that will support a middle school curriculum strategy for educational robotics. These evolving products can be examined at the general SPIRIT Education website (<http://www.ceen.unomaha.edu/TekBots/SPIRIT2/>) and include the following components of the curriculum and its support efforts:

Teacher Lessons and Lesson Ideas: A large number of edited, refined, and tested teacher lessons (260 as of December, 2011) have been posted to the SPIRIT website and the related cyberinfrastructure database. A total of nearly 100 other lessons are in various states of development for eventual postings and further refinement. Teachers also use the website as a place to share ideas and exchange evolving lesson prototypes.

Technical Tutorials and Video clips: The project is generating an extensive number of technical tutorials (print and video) that help teachers to build and test their CEENBoT. These tutorials are both interactive on the web, as well as available by downloadable PDF.

Lesson and Teacher Resources: A variety of lesson resources such as an "Engineering Notebook", "Robot Games", and other resources, such as a list of "Misconceptions in Science" are being created and posted by SPIRIT teachers as possible prototypes for use by other teachers.

Evaluation Instruments: A growing set of evaluation instruments have been created to look at teacher and student change as related to their STEM knowledge, skills, and attitudes. Student assessment development has been undertaken collaboratively with the 4-H Robotics and GIS/GPS project, as mentioned earlier.

Reports, Articles, and Presentations: The many outreach presentations for the SPIRIT project, as well as selected reports, article manuscripts, and other overview documents are also posted on the SPIRIT website.

Book in Press: Robotics in K-12 Education. The SPIRIT project staff have also worked on a book due to be published in early 2012 related to robotics in K-12 education. The book was edited by Drs. Bradley Barker, Gwen Nugent, Neal Grandgenett, and Viacheslav I. Adamchuk, and is a joint effort between the 4-H Robotics / GearTech 21 team and the SPIRIT team. *Robotics in K-12 Education: A New Technology for Learning* focuses on the use of educational robotics to stimulate science, technology, engineering and mathematics (STEM) learning in K-12 formal and informal educational environments. The book provides a synthesis of existing educational robotics research including: a) theoretical base for using educational robotics for STEM education, b) effectiveness in STEM education and promoting positive attitudes towards STEM, and c) promoting a research agenda to move the field forward. The innovative programs discussed target both formal and informal learning environments, as well as robotic competitions. The book contract was received from IGI Global (www.igi-global.com) and is in press, for publication in early 2012.

3. Internet Site(s):

As mentioned in other report sections, the SPIRIT project has generated a system of websites with a great number of archival documents, lessons, instruments, and movie clips. Here are a few of the key website URLs:

Curriculum Information

SPIRIT Education Components of the Website:

<http://www.ceen.unomaha.edu/TekBots/SPIRIT2/>

General Project Information

SPIRIT General Website:

<http://www.ceen.unomaha.edu/TekBots/>

Cyberinfrastructure Information

SPIRIT Cyberinfrastructure Prototype:

<http://spirit.unomaha.edu/>

Videoclip Sample Information

SPIRIT Video Clip Sample: (sample / others on website)

<http://www.ceen.unomaha.edu/TekBots/Shared/Video/jumbotron07/>

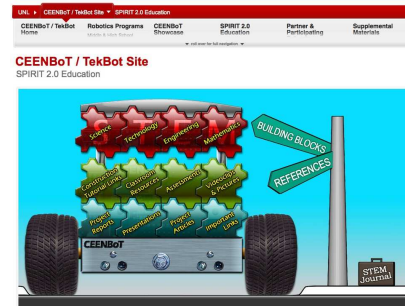

Contributions

1. Contributions within the principal discipline(s) of the project:

As of December, 2011, the SPIRIT project continues to aggressively pursue sustainability and expansion, and is dedicated to providing a solid contribution to the discipline(s) of STEM Education. The contributions of the project to date are essentially the following.

Contribution 1: The project has conceptualized the structure of an educational robotics “touch point” curriculum for middle schools that will enhance the student learning of STEM concepts using a flexible CEENBoT robotics platform. A total of more than 260 lessons have been developed, edited, and posted, and are now in final form. A total of 100 more lessons are in various stages of development. Some of these lessons can also be modified further for use in an elementary or high school classroom as well.

Contribution 2: The project has continued an educational research agenda to help determine the instructional effectiveness of the lessons in an extended development process, using peer editing, expert review, pilot testing, and field-testing strategies. The individual lesson pilot testing process is fully underway, and some initial field-testing is also being undertaken. Pilot testing and field testing efforts will be expanded during 2011, with selected schools. Pilot testing

and field-testing of the evolving SPIRIT curriculum received IRB approval in 2009, and is continuing in compliance with that approval process. The project has also collaborated on a book to be published in 2012, entitled "*Robotics in K-12 Education: A New Technology for Learning*" as facilitated by IGI Global.

Contribution 3: The project has collaborated with another NSF project (4-H Robotics and GPS/GIS / GearTech 21) to contribute to a series of interactive and focused assessments to help teachers determine what STEM concepts students are learning and their resultant attitudes. The various versions of several of these instruments have already been developed and validated. New instruments continue to be worked on and refined, with more efforts in 2012 planned.

Contribution 4: The project has extended the original TekBot learning platform into a newly developed and much more powerful and flexible CEENBoT educational robotics platform for use with the curriculum, including detailed technical enhancements, hardware tutorials, software guidelines, a GPI interface, a graphical calculator interface, an application programming interface, and a flexible hardware and software system that permits creative enhancements by a student or teacher.

Contribution 5: The project has created an innovative cyberinfrastructure support environment that includes a flexible sequencing of lessons, student and teacher support materials, assessments, technical information, and technical tutorials. Progress has continued in the development of this technically challenging interface, and the cyberinfrastructure continues to be expanded and refined. Recent innovations in the cyberinfrastructure include the use of released standardized test questions, that are being mapped to each of the STEM content topics.

Contribution 6: The project has conceptualized a teacher training strategy that can be scaled nationally, where local community colleges, local educational service units, and university computer electronics and engineering departments, might assist with technical aspects of robotics construction, while the corresponding educational training is offered via distance education, or in local colleges of education. An online graduate course has been designed and is continuing to be refined to help teachers to more efficiently learn to use educational robotics in the instruction of their STEM disciplines.

Contribution 7: The SPIRIT project has continued to produce and publish articles related to the use of robotics and educational technology in the systematic instruction of science, technology, engineering and mathematics. A mix of articles have been published that involve both the theoretical base, results of the project itself, and implications for teachers, as well as educators in other environments, such as after-school programs and summer camps. Some articles have been published in collaboration with the 4-H Robotics and GIS/GPS Project, as well as other theoretical researchers, such as at the College of William and

Mary. As mentioned earlier, an educational robotics book is also in press for release in early 2012.

Contribution 8: The project has successfully initiated a non-profit, university start-up business to produce and service the CEENBoT that is called CEENBoT INC. This commercial element of the SPIRIT effort was needed in order to supply teachers and schools with the needed robots for their classroom on a continual basis, and to service the robots as needed. This university startup company, CEENBoT INC., successfully competed for NSF SBIR Phase I funding, and was awarded \$150,000 of startup funds during 2010. This new production company effort (as a funded university start-up company) also represents a new model of blending university and business approaches, to better support teachers and schools in their use of educational robots.

The project is continuing to routinely undertake national conference presentations and papers. Professional engineering conferences are also being included in the dissemination of the SPIRIT curriculum strategies and project results. The SPIRIT project has already made presentations at meetings of the International Technology and Engineering Educators Association (ITEEA), the American Evaluation Association (AEA), the Advanced Technologies in Education (ATE) conference, the Association of Mathematics Teacher Educator's (AMTE) conference, Society for Information Technology and Teacher Education (SITE) conference, American Educational Research Association (AERA) conference, and the Association for the Advancement of Computing in Education Educational Media conference (Ed-Media), and the High Impact Technology Exchange Conference (HI-TEC).

As of December 2011, the SPIRIT project has also successfully established a systematic teacher professional development model for middle school teachers. Middle schools, high schools and community colleges in nearby states are also now showing an interest in further collaborations for extending the model. In particular, educational institutions within the three additional states of Iowa, North Dakota, and South Dakota have begun to participate in the program and a special session is planned for a four-state Working Connections Conference. This interest and participation may eventually result in having more states host educational robotics workshops for teachers, particularly at a community college in the area. The SPIRIT project leadership has also been in close contact with the Midwest Center for Information Technology (funded by the NSF Advanced Technologies in Education program), which includes ten leading community colleges in a four-state region (Nebraska, Iowa, South Dakota and North Dakota). These discussions are continuing, and we are excited about expanding steadily into other states, and other levels of formal education, such as the community college level. In addition, several community colleges are also becoming interested in working closely with our SPIRIT project for undertaking their own educational robotics initiatives. We even assisted Central Community College in Nebraska in writing a NSF Advanced Technology in Education (ATE) proposal that was successfully funded, and that now includes educational robotics and lesson development activities on site at that community college, and that uses our lesson cyberinfrastructure.

2. Contributions to other disciplines of science and engineering:

Continuing in 2012, the information technology related activities of the SPIRIT Project have the potential to further initiate new strategies for the use of the cyberinfrastructure in the delivery of discipline related content information via the Internet. This would include fields such as English, History and Literature. The SPIRIT project is striving for a high quality, inexpensive, flexible, and cyberinfrastructure-supported educational robotics curriculum that can in turn help scaffold student thinking and promote the curiosity needed for sustained inquiry, as described in *How People Learn* by the National Research Council (1999). We are proud of our progress toward this challenging goal, and that the many demonstrations of our cyberinfrastructure at national conferences and at teacher presentations have been generally well received.

The educational robotics curriculum will permit teachers to choose their level of classroom engagement in the construction of the CEENBoT, with options ranging from a bag of parts to fully completed robots. By the end of 2012, we anticipate a fully developed series of curriculum lessons and units, which will include various instructional components, such as assessments and student support sheets. The lessons are being steadily completed and indexed, building an Internet-accessible database system in which teachers can tailor and personalize their own curriculum enhancements. Teachers can choose from a set of web forms that ask for relevant parameters, such as grade levels, content topics, or desired mathematics and science standards, to assist the database in generating the tailored curriculum sequence. The curriculum generated can then be printed or stored by a teacher for later use. In addition to the curriculum, a software-based “On-Call Technician” is in development, and will eventually provide classrooms with an interactive method for diagnosing potential problems with their robots.

In further support of the SPIRIT project and the sustainability of this educational robotics initiative, the Computer and Electronics Engineering faculty are establishing a new research program in educational robotics within the department that could eventually establish it as a national center for educational robotics research and development. Designing advanced uses of graphing calculators and smart phones as a robot control device is just a couple of examples of a very specific SPIRIT application that is already being undertaken by such a new research and development effort. Another example might be the creation of the CEENBoT avatar for computers to teach programming concepts or gaming/logic to solve maze and resource problems (like finding a lost astronaut within a battery resource limit. This research will use a K-20 context that would involve Ph.D. students looking at optimal control and gaming theory. Connections to artificial intelligence, stereoscopic vision, proximity sensors, on board sonar and high-level digital signal processing, would all be topics that would be potentially considered by the researchers, as well as other topics not yet identified.

The SPIRIT effort has led to some excellent university-level engineering contributions, as well as our K12 education efforts mentioned previously. The CEENBoT is currently being used in university level engineering coursework at the Peter Kiewit institute, providing a nice synergy between university and K12 education. For example, the CEENBoT is used in a Computer and Electronics Engineering Fundamentals course (CEEN 1030). This is the first undergraduate engineering course taken by students in the first semester of their freshman year. As a part of a lab component, students receive the CEENBoT in kit form: bare circuit boards, electronic

components, mechanical components, nuts, bolts, screws, motors, etc. Students solder components onto the four circuit boards and assemble the mechanical parts to produce a working robot. They also further use the CEENBoT in the Microprocessor Applications course (CEEN 1060). This further course studies assembly language, microprocessor system architecture, and C programming. As an example of an embedded system, the CEENBoT is used to introduce system level C programming. Students also use their assembly skills to construct a microcontroller PCB with an LCD display. The microcontroller is then programmed using the C language for motor control and sensor inputs. Other programming assignments introduce port access and peripheral initialization. In the Electrical Circuits I course (CEEN 2130), students are challenged to design the circuitry required to disable CEENBoT operation when the lights in the lab are extinguished. A second task is assigned to design the circuitry necessary for the control of DC servo-motors. Finally, in CEEN 2220 Electronic Circuits I, university students undertake a CEENBoT challenge of taking a design modification to the prototype stage, and examining device bias and switching characteristic and modeling, project management topics, and fundamental control theory.

Some contributions are also being made to community college STEM instruction in the context of the SPIRIT project. At Metropolitan Community College (MCC) in Omaha, Nebraska, the CEENBoT is being used in basic algebra instruction. For example, in a lesson focusing on graphing on the Cartesian coordinate system in MCC's developmental Algebra course, the CEENBoT is used to increase the engagement of the students and to connect algebra to real life applications in robot navigation. Using a remote controlled CEENBoT as an instructional platform, students drive on a rectangular floor grid and discover various introductory concepts, such as slope, that are covered in the textbook and that are illustrated in robot movement. Topics covered in the algebra and robot activity include: ordered (x,y) pairs, x-intercept and y-intercept, quadrant designations (I, II, III, & IV), algebraic slope, and symmetry with respect to the axes and origin. The community college instructors involved in these robotics lessons have found that the classroom treatment of straight lines and slope is generally much more successful when it follows the use of an introductory educational robotics exercise using the mobile robot in this manner. Furthermore, the student conversation in the course frequently turns to the CEENBoT itself, how it was constructed, how it operates, and the underlying principles and concepts embodied in robotics in general.

On the College of Education side of the SPIRIT efforts, the project educators have initiated work to establish an online journal called The Journal for Science, Technology, Engineering, and Mathematics for Classroom Teachers. It will be a resource designed primarily for classroom teachers with a goal of creating awareness, discussion, and the sharing of innovative ideas for STEM Education. This online journal will eventually provide a nice educational and peer-reviewed venue for teachers to contribute their educational robotics ideas to the professional literature.

In further support of the SPIRIT educational research needed for the sustainability of the SPIRIT project, the University of Nebraska at Omaha College of Education has established the Office of STEM Education, which will further support SPIRIT as one of its key initiatives. The Office of STEM Education was designed to facilitate a unified and long-range effort on improving STEM education, in projects such as SPIRIT. The STEM Office and its members are focused on many aspects of STEM education that

relate closely to SPIRIT, including improving teacher training for STEM teachers, increasing the number and diversity of STEM teachers, providing innovative STEM curriculum, and researching STEM interventions. The philosophy of this office is to particularly concentrate on supporting the educational research needed to assist in innovative STEM instruction and in supporting STEM teachers. The SPIRIT project is an excellent example of combining science, technology, engineering, and mathematics in the school curriculum, and the UNO Office of STEM Education is excited about supporting and sustaining the SPIRIT project on a long-term basis.

As the SPIRIT project expands its educational robotics efforts during 2012, there are expected to be significant long-range contributions to science, technology, engineering and mathematics education. Several examples are becoming apparent at this time for our potential long-range contributions. First, our new evolving robotics platform (the CEENBoT) will be a flexible, programmable (in various ways), inexpensive and engaging teaching and learning platform. Second, we are developing the foundation of an excellent “touch point” cyberinfrastructure-based curriculum to be used with this platform, including prototype lessons, teacher resources and technical tutorials. Finally, we are creating a professional development model for helping teachers to learn about educational robotics and its potential use in STEM teaching and learning.

3. Contributions to the development of human resources:

This SPIRIT project has been continually striving to contribute to the need for encouraging more women and underrepresented minority groups to consider engineering as a profession. Several training sessions in each teacher training institute has been dedicated to this topic, and we have initiated discussions with teachers related to this important national issue and the resultant poor U.S. engineering enrollments, to help our teachers become more aware of the gathering national “storm” in engineering education and global competition.

We are also continuing to address minor human resource challenges in our curriculum writing process, as we carefully undertake collaborative lesson writing within the SPIRIT project. As described earlier in the report, we employ current classroom teachers to help write lesson drafts that support the SPIRIT curriculum. These practicing teachers are a valuable human resource and we have been impressed with both their creativity and energy. However, they are generally inexperienced writers of a professional level curriculum, and we are carefully editing and refining teacher lessons and resources. Our lesson development and editing process, representing a relatively dynamic human resource model, is illustrated in the report appendix. To assist with achieving as strong as lessons as possible for the SPIRIT curriculum, the writing team produces lessons around instructional (I’s) components in STEM categories that have been previously developed and checked by a content team. The practicing teachers then work from these core components, assisted by expert curriculum writers. The SPIRIT curriculum team continues to strive for educational excellence in all products produced, and only the most refined and promising lessons are edited, illustrated, and posted to the system. Lessons are also posted to the SPIRIT curriculum in two different ways. The first way is the “complete lesson” format where teachers can come and download AEIOU lessons as they are originally. The second way is in the “interactive database” format. In

this way, teachers can mix and match what components they feel would best meet their individual curriculum needs.

To keep this extensive human resource effort of writing SPIRIT lessons as organized as possible we have established a lesson development and tracking system online so that the SPIRIT leadership can see what status different lessons are in within the curriculum development pipeline, as well as what lessons are being populated. This human resource model related to teacher curriculum development is being prepared as a manuscript to be submitted to a refereed journal (such as *Learning and Leading with Technology*) to help to document this successful model in the professional literature.

As the SPIRIT project continues to evolve, grow, and expand into 2012, we believe that we are also developing an extended team of experienced teacher consultants who have significant expertise in curriculum development, as it relates to educational robotics and the instruction of STEM concepts. The SPIRIT project team, and the many collaborative partners that we have engaged, have not only become a valuable resource to the curriculum writing process being undertaken in this project, but will also eventually become an important source of experience and expertise, as we assist other educators around the country, to benefit from the SPIRIT lessons and the related curricular resources.

4. Contributions to the physical, institutional, or information resources that form the infrastructure for research and education:

Continuing into 2012, the SPIRIT project is developing curriculum-related strategies to help map engineering activities to traditional STEM coursework and the needed STEM outcomes as identified by the public schools. The SPIRIT project has also collaborated closely with the 4-H Robotics Project to refine several shared prototype instruments to help quantify STEM related achievement by students within an engineering and educational robotics context. It is anticipated that school districts will be able to use these instruments to help demonstrate STEM achievement for their students when using selected educational robotics lessons.

The SPIRIT Project is developing a series of lessons and educational resources (such as worksheets, teacher grading rubrics and movie clips) that interested teachers can use within their own classrooms, to help engage students in educational robotics within traditional mathematics and science classes. Thus, the SPIRIT educational robotics lessons and lesson ideas can form a support structure for classroom innovation, where STEM connections can make concept learning more interesting and more realistic. A sample SPIRIT lesson is included in the report appendix.

Working closely with educational researchers at other institutions, such as Iowa State University and the College of William and Mary, the SPIRIT project is also contributing to cutting-edge educational research being undertaken related to Technology Pedagogical Content Knowledge (TPACK). The use of educational robotics to help teachers to increase their TPACK, in both in-service and pre-service settings, is very promising and the SPIRIT education team has already contributed to published articles in this new educational research area in *Learning and Leading with Technology*, as well as the *Journal for Mathematics Education Leadership* of the National Council of Supervisors of Mathematics, and even contributed a chapter in the TPACK Handbook, published by the American Association of Colleges for Teacher Education (AACTE).

Other collaborative articles related to TPACK and SPIRIT have been published or accepted for publication in journals such as *Research Highlights in Technology and Teacher Education*, *Journal of Technology and Teacher Education*, *the Journal for Youth Development*, and *the Journal of Research on Technology Education*, and *Issues in Undergraduate Mathematics Preparation of School Teachers*.

As described earlier, to support the use of educational robotics by teachers, the SPIRIT project has also developed a university start-up company to help produce, distribute and support the CEENBoT. Mr. Dennis Deyen, a well-respected and well-experienced engineer and businessman, has been appointed Chief Technology Officer of CEENBoT Inc. The company is producing CEENBoT kits for teachers, and is seeking a sole source provider agreement with the University of Nebraska to provide the educational robots, add-on kits, and parts needed, for the national sustainability of the SPIRIT project. Additional personnel have been retained in the company to provide engineering technical support, and to meet existing project orders as well as to streamline procurement and manufacturing capabilities. A NSF SBIR Phase I grant was awarded in late 2009/early 2010 and is assisting CEENBoT Inc. in its early formative stages. This commercialization effort, was written into the SPIRIT grant proposal, and is in direct support of SPIRIT sustainability, while also supporting university, K-12 schools, and business partnerships, that we see as promising for the continued and long-term support of STEM education by the SPIRIT project.

5. Contributions to other aspects of public welfare beyond science and engineering, such as commercial technology, the economy, cost-efficient environmental protection, or solutions to social problems.

As mentioned earlier, the SPIRIT project is developing and refining various lessons, delivery structures, assessment instruments and protocols to help support and investigate the impact of educational robotics lessons on student STEM achievement. Continuing into 2012, there is also a focused effort within the curriculum development process, by all involved, to help to ensure that the CEENBoT materials represent a relatively “green” technology, and that these materials also help students to understand efficient and ethical energy use, as well as appropriate ways to get rid of electronics waste materials, such as batteries. We are also considering various project development ideas that might further connect with ethically responsible engineering.

The SPIRIT project is also now undertaking a new model of commercialization that will permit a low cost engineering strategy for many schools that might not be able to afford expensive robotics kits. Educational robotics can often be an expensive STEM endeavor for many schools, and we hope that the CEENBoT will eventually be a very cost-effective alternative for these schools if they wish to have their students participate in educational robotics activities. This “SPIRIT-CEENBoT alternative” will help schools to make their STEM coursework more affordable, by access to a low cost, engaging, and flexible educational robotics platform, which also includes a convenient curriculum support structure. Thus, we hope to make the SPIRIT project and the CEENBoT a useful and cost-effective alternative for schools, who might not otherwise be able to have their students participate in this exciting context for STEM education.

Objectives and Scope

1. Provide a brief summary of the work to be performed during the next year of support if changed from the original proposal:

[No] Objectives and scope remain unchanged from the original proposal.

Project Examples and Illustrations

A detailed appendix of SPIRIT project samples is also available. Further samples of the project work can be found at <http://www.ceen.unomaha.edu/TekBots/SPIRIT2/> or requested.

SPIRIT 2.0

Report Appendix

Samples of SPIRIT 2.0 Work (December 2011)

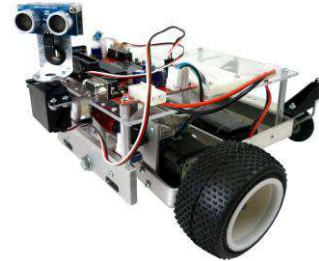

SPIRIT 2.0 Samples

| | |
|---|------|
| SSW 1. SPIRIT Profile..... | A-2 |
| SSW 2. SPIRIT Pictures in Action..... | A-3 |
| SSW 3. SPIRIT Showcase in Action..... | A-11 |
| SSW 4. Nebraska Robotics Showcase Brochure..... | A-20 |
| SSW 5. Comparison of TekBot and CEENBoT Information..... | A-28 |
| SSW 6. Lesson Editing Structure..... | A-29 |
| SSW 7. Sample SPIRIT 2.0 Lesson..... | A-30 |
| SSW 8. Sample CEENBoT Game..... | A-38 |
| SSW 9. Sample Tutorial..... | A-39 |
| SSW 10. Sample Pages of Student Engineering Notebook..... | A-48 |
| SSW 11. Spreadsheet of Robotics Lesson Ideas..... | A-68 |
| SSW 12. Investor's Business Daily..... | A-77 |
| SSW 13. Engineering Nebraska Article..... | A-78 |
| SSW 14. UNL Annual Report..... | A-80 |
| SSW 15. Columbus Telegram Article..... | A-82 |
| SSW 16. Dream It Do It Brochure Featuring CEENBoT..... | A-84 |

SPIRIT/GearTech 21 Robotics Collaborative Assessments

| | |
|---|-------|
| SSW 17. Teacher Professional Development Survey..... | A-86 |
| SSW 18. Teacher/Facilitator Pilot Test Feedback..... | A-91 |
| SSW 19. Student Feedback Form..... | A-92 |
| SSW 20. Sample Robot Content Assessment Questions..... | A-93 |
| SSW 21. Sample 21 st Century Skills Questionnaire..... | A-97 |
| SSW 22. Sample Interest Questionnaire..... | A-99 |
| SSW 23. Longitudinal Survey..... | A-102 |
| SSW 24. Kuder Career Planning Survey Sample..... | A-105 |
| SSW 25. SPIRIT IRB Notification Letter..... | A-107 |
| SSW 26. Sample Standardized Test Question Set..... | A-108 |
| SSW 27. Open Ended Big Ideas Content Survey..... | A-109 |

SPIRIT 2.0 Websites and Samples

| | |
|--|---|
| SPIRIT Education Components: | http://www.ceen.unomaha.edu/TekBots/SPIRIT2/ |
| SPIRIT Cyberinfrastructure Prototype: | http://spirit.unomaha.edu/ |
| SPIRIT General Website: | http://www.ceen.unomaha.edu/TekBots/ |
| SPIRIT Video Clip Sample: (sample / others on website) | http://www.ceen.unomaha.edu/TekBots/Shared/Video/jumbotron07/ |

SPIRIT: Silicon Prairie Initiative for Robotics in IT

UNO College of Education Core Team Members

Neal Grandgenett, Elliott Ostler, Bob Goeman, Neal Topp, Paul Clark, Jim Wolfe, Bill Schnase, Steve Hamersky, Brian Sandal, Mel Mays, Lynn Spady, Derrick Nero, Lisa Showalter

UNL College of Engineering Core Team Members

Bing Chen, Alisa Gilmore, Roger Sash, Herb Detloff, Steve Eggerling, Ken Townsend



Website: <http://www.ceen.unomaha.edu/TekBots/SPIRIT2>



The "Silicon Prairie Initiative for Robotics in IT" (SPIRIT), a collaboration between the University of Nebraska and area schools, was a three-year Comprehensive NSF ITEST Project for Students and Teachers, that has expanded into a NSF Discovery K12 Learning Project. SPIRIT targets science and mathematics teachers in grades 5-9, each of whom receives extended professional development and follow-up support in developing in-school curricular activities related to educational robotics. More than 12,000 students have participated through in-school and summer

programs. The centerpiece of the project is a university level CEENBoT (TM) learning platform that has been adapted to the middle school level. This platform can be used to demonstrate basic applications in wireless, video and signal processing, sensors, video displays, electronics, control systems, embedded systems, digital logic and introductory programming. The curriculum being developed in the project employs CEENBoTs as a fundamental strategy for problem-based instructional activities. It is adaptable, expandable and cost-effective, providing learning experiences that can extend into high school and college. Results are being disseminated through publications and presentations, teacher workshops, displays prepared for school districts and collaborations with other universities using robotics platforms. An interactive, dynamic website has been created with modules and tutorials, uploadable programs, videoclips and links to research. As of Fall 2011, more than 300 teachers have been trained in extended workshops and graduate courses and more than 250 Internet-based lessons have been created. Teacher surveys and student assessments have documented significant teacher growth in problem-based learning, robotics, electronics, and engineering design.

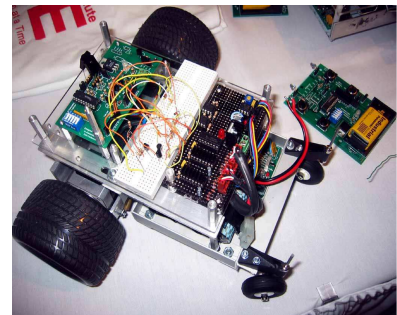

SSW 2. SPIRIT IN ACTION (PICTURES)



Students working with the engineering process to come up with a design to better the robot.



Students displaying their engineering notebook drawings and plans.



Teachers learning how to use the electronics equipment before they build the robot.



Teachers learning to drive their robots and having a bit of an impromptu robotic Sumo competition.



Teachers working together on their robots.



A teacher works on adding some resistors to a circuit board.



Three students investigate how the circumference of the wheel is related to the distance traveled.



Students investigate the formula for distance = rate x time.



Students investigate the relationship between the circumference of the wheels and the distance traveled upon various wheel rotations.



Students investigate the formula for distance = rate x time.



Students exploring the capabilities of the CEENBoT in a series of testing trials.



A student takes notes for future reference on the workings of the robot.



These students check the LCD for important data they have gathered.



These three students are gathering data from driving experiments they have conducted.



A student manipulates a virtual CEENBoT through an obstacle course.



This student is using a chain to see how much a weight a robot can pull with a pulley system.



The students construct a maze for the robots out of everyday materials.



A student examines angle of incidence options for a CEENBoT bump course.



The CEENBoTs and drivers follow the path through the maze.



A student tests advanced drive functions they added to the CEENBoT.



A teacher examines GPS coordinates of CEENBoT locations with his students.



Instructors give detailed directions in the use of the CEENBoT to a group of teachers.



Dr. Mitchell shows students how to make a small robot work with lemon batteries.



A student tests his driving abilities with the CEENBoT.



These students test each others driving skills and learn the controls.



Other robots are used to test the skills of students on momentum and force.



A group of students examine algebraic slope of a stalling robot up a ramp.



These students are modifying their CEENBoT for an experiment.



A physics teacher helps students understand gear ratios.



Teachers work together with the CEENBoT Commander programming interface.



Teachers investigate the new mechanical arm on the CEENBoT.

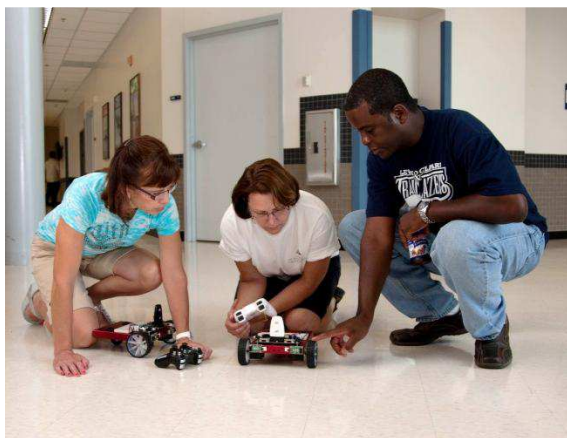

Teachers brainstorm on ideas for using the CEENBoT in their classrooms.



A couple of students investigate the new single-board CEENBoTs.



CEENBoT Parking Garage



CEENBoT Charging Station



Cardstock prototype design for plastic shell of CEENBoT.

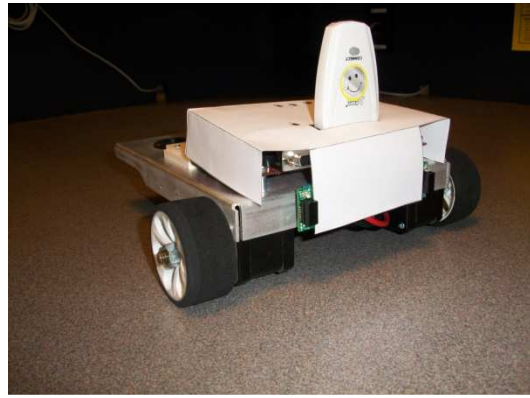

Front view of cardstock prototype design for plastic shell of CEENBoT.

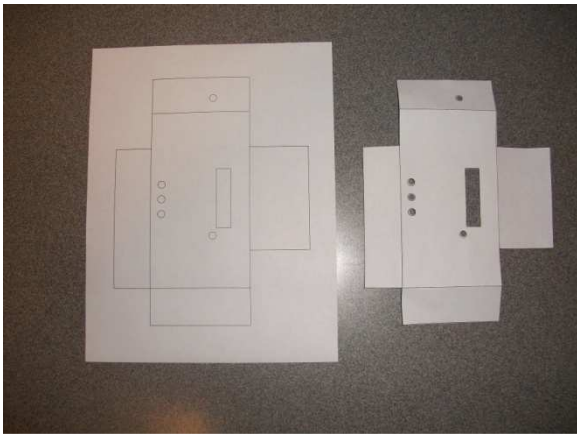

Cardstock design template for CEENBoT plastic shell.



Modifying the robot for the soccer and programming challenges.



Programming the robot with the CEENBoT Commander development environment.

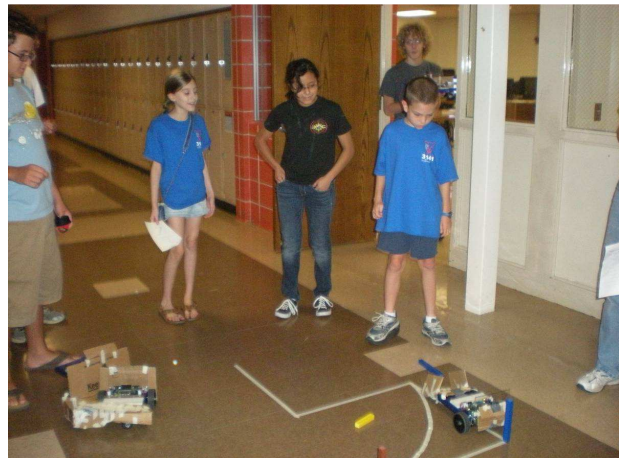

Testing the robot programming.

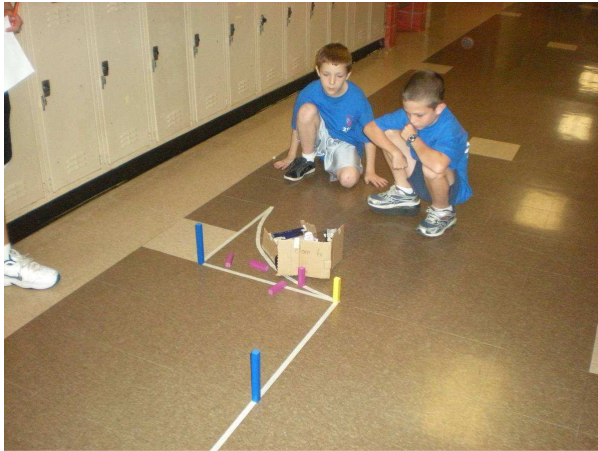

Programming the robot to follow a curved path.

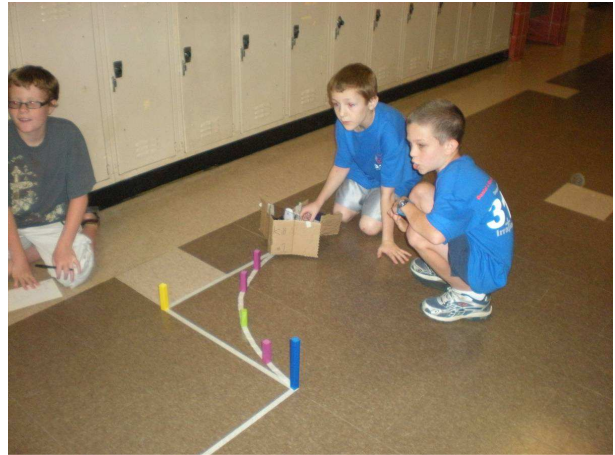

Robot programming challenge illustrated a modular design approach.



A robot modified to carry a video camera phone.



A soccer challenge stressed modification of the robot.

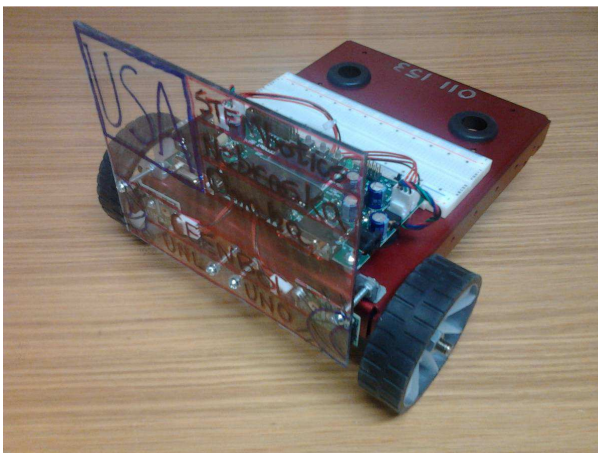

Shield modification used during the summer field test.

SSW 3. Summary of 2011's SPIRIT Robotics Showcase:

- ✓ The SPIRIT Robotics Showcase is featured as part of the newly created Nebraska Robotics Expo which also includes the First LEGO League Competition



- ✓ Over 300 students from grades K-12 attended our Showcase event on Saturday, February 19th, 2011 at the Strategic Air and Space Museum in Ashland, NE along with teachers and many parents
- ✓ 60 teams from 24 schools participated in this third annual event
- ✓ Sponsors included NSF, OPPD, Lockheed Martin, Avionics Interface Technologies, Union Pacific, Raytheon and NASA Space Grant

- ✓ Presentations and demonstrations were conducted by Lockheed Martin, UNMC, CEENBoT, INC, Avionics Interface Technologies, Raytheon and Central Community College and proved to be a great success and very popular with students, teachers and parents
- ✓ The Game Booths area included six different robotics activities



Student wins the Ball Course arena

from programming to CEENBoT Tae Kwon Do and was enormously popular among the whole Expo crowd

- ✓ News coverage by many eastern Nebraska news outlets
- ✓ IEEE student organization contributed to building road courses and manning the snack booth
- ✓ All students received t-shirts
- ✓ All participating schools received CEENBoTs, thus infusing their classrooms with new materials related to engineering with the continuing promise of exposure to more K-12 aged students
- ✓ An audience poll resulted in ALL students responding with excitement and enthusiasm about engineering
- ✓ CEEN freshman seminar students served as judges and guides providing them with a service learning experience
- ✓ All the events were well synchronized and went off without a single hitch thanks to our organizer, Rita Corell

Plans for Nebraska Robotics Expo 2012:

- Due to the success of the previous three years, organization is underway for 2012
- Feature a new Creative Visual Arts Expo for K-12 art students, providing them with an opportunity to lay down their own future visions/concepts in the world of robotics
- Feature other new (and updated) events and more complex learning activities available due to developmental advances on the CEENBoT
- Update robotics learning stations (Game Booths area) for hands-on instruction and student discovery
- Additional schools will be added to the Showcase to expose greater numbers of students to the promise of engineering as a career destination
- Increase the number of corporations providing presentations on their technology as an outreach to the community
- Continue the infusion of engineering tools into more classrooms until there is a continuity of exposure throughout the K-12 period
- Utilize the Showcase as an opportunity for teachers to share their classroom materials related to engineering with one another and to interact with industry sponsors to enhance their understanding of engineering design and philosophy

SPIRIT Robotics Showcase 2011 Photos



Student plays with the CEENBoT at the GPI/TI Programming Mode Game Booth.



A team (middle-background) assists their teammate during a "blind driving" competition with the CEENBoT

SPIRIT Robotics Showcase 2011 Photos

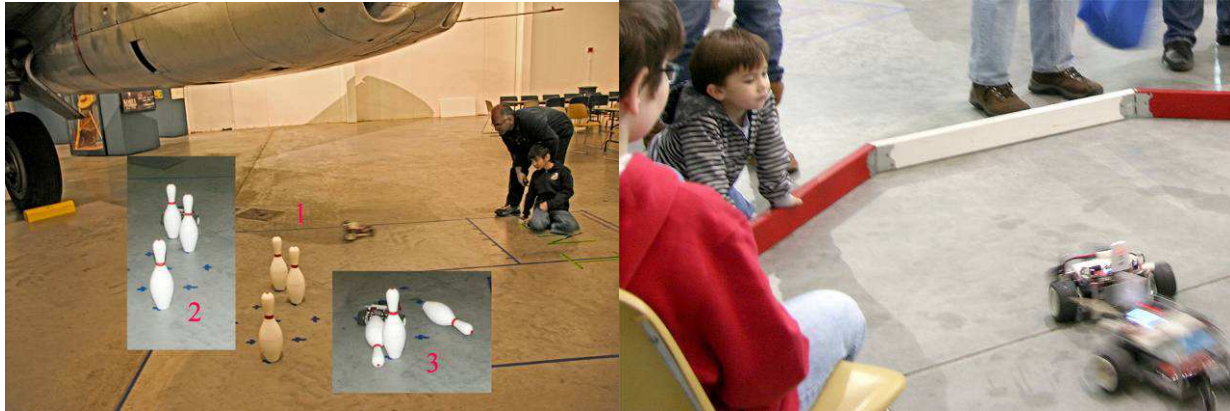

CEENBoT Bowling Game Booth (left) and CEENBoT Tae Kwon Do (right)



Volunteering CEEN Seminar undergraduates for the CEENBoT Showcase with Nebraska Governor Dave Heineman.

SPIRIT Robotics Showcase 2010 Photos



Student team drives their TekBot® through the Ball Arena.



Students take turns with Jason Harper's "Mars Volta" remote controlled riding robot.

SPIRIT Robotics Showcase 2010 Photos

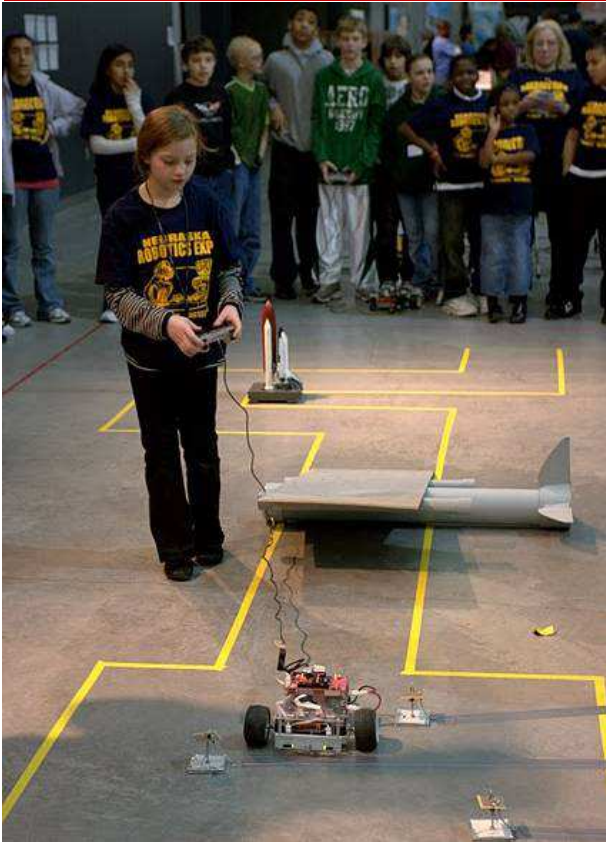

Student navigates her team's CEENBoT through the Road Course electronic "minefield" (left). Artist Dan Wondra was on hand to do caricature sketches of participants (right).



Pamela Galus and students from Lothrop Elementary with Gov. Dave Heineman

SPIRIT Robotics Showcase 2009 Photos



An all-girls middle-school TekBot® team pushes to score in the final seconds.



The Tera Heights all-girls TekBot® team navigates the road-obstacle course.

SPIRIT Robotics Showcase 2009 Photos



Many middle/high school students, teachers, and parents attended this Saturday event.



The Benson High School CEENBot™ team pilots the ball maze wirelessly.

Nebraska Robotics Expo

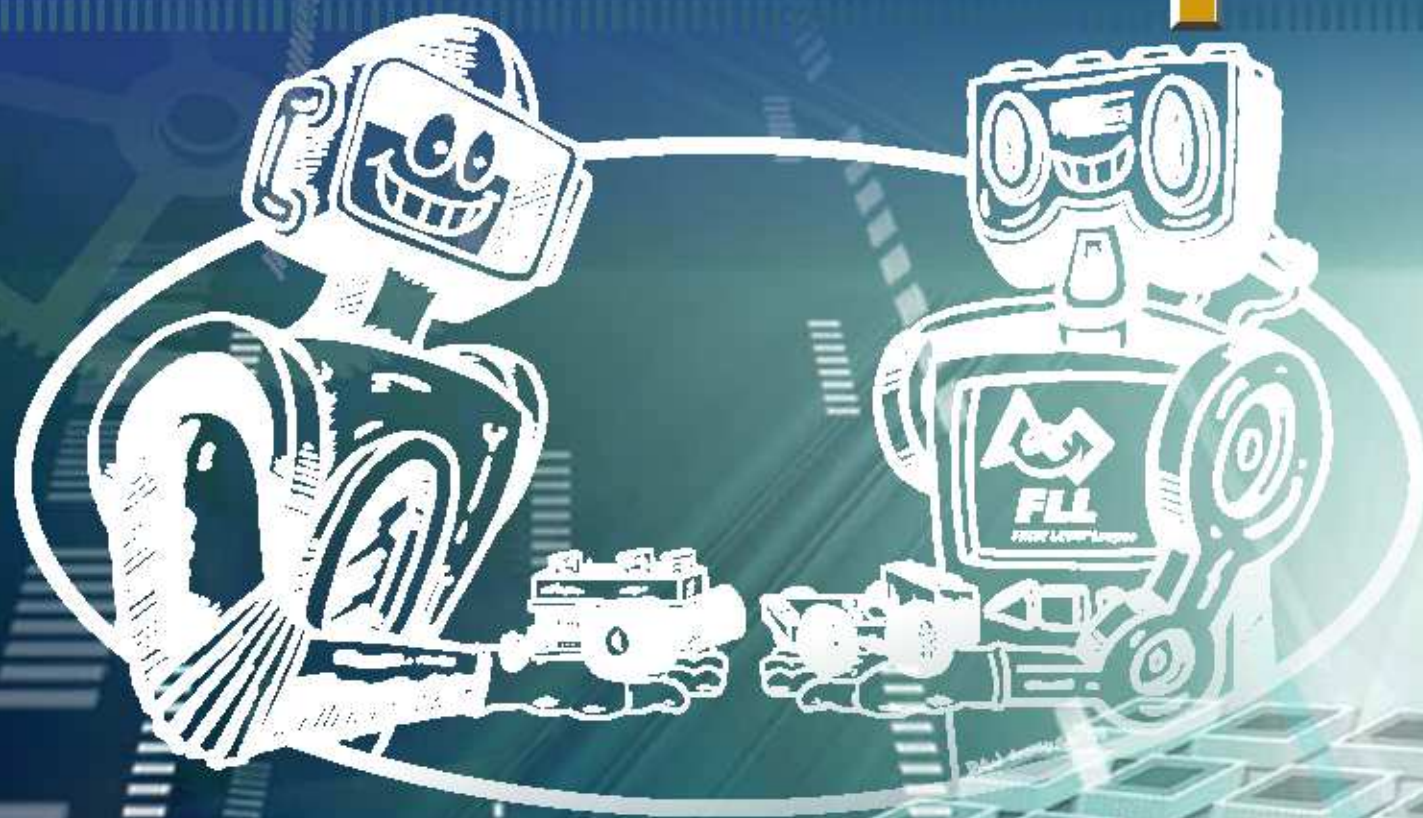

GEENBOT™ SHOWCASE *FIRST®* **LEGO® LEAGUE**

Saturday, February 19, 2011
Strategic Air and Space Museum
Ashland, Nebraska

Welcome to Nebraska Robotics Expo

The Expo represents a collaborative effort between the SPIRIT Project GEAR-Tech-21 4-H Youth Development project, and **FIRST**® LEGO® League to create an outstanding robotics competition for about 1000 of our local and greater Nebraska area youth. As you cheer on our future scientists and engineers, we encourage you to visit the CEENBoT™ Showcase, **FIRST** LEGO League events, sponsor booths, and museum exhibits.

The CEENBoT Robotics program is featuring a terrific new robot this year, called the 324 CEEN-BoT, which makes its debut in the showcase today. The robot has a totally new and enhanced platform, featuring multiple autonomous programming options that include a TI Graphic Calculator Interface, a Graphical Programming Interface (GPI) and programming in the C language with an Application Programming Interface (API).

Public Invited to Play

A special feature of the showcase this year is the CEENBoT Games, open to the general public, including kids of all ages! We have several booths set up for anyone to explore the new 324 CEENBoT. Come play CEENBoT Tae Kwon Do, Bowling, Driving a Maze, Bumpbot Mode, Precision Driving and GPI/TI Programming Challenge.



About CEENBoT Robotics

The CEENBoT Robotics program has its roots in the SPIRIT program, which stands for the Silicon Prairie Initiative for Robotics in Information Technology. The SPIRIT program was funded by the National Science Foundation and has provided the instructional foundation needed to help teachers use educational robotics to teach important science, technology, engineering, and mathematics concepts. The current CEENBoT Robotics program combines the technical expertise of engineering professors and staff in the University of Nebraska-Lincoln Department of Computer and Electronics Engineering with the educational expertise of professors and staff in the College of Education at the University of Nebraska at Omaha.

The collaboration is developing a national robotics curriculum for middle schools.

The CEENBoT Showcase

The Nebraska Robotics Expo marks the third season for the CEENBoT Showcase. With over 60 teams participating this year, we have doubled the teachers and students from last year's event.



CEENBot™ SHOWCASE

About the SPIRIT Program

Through the initial funding for the SPIRIT program more than 250 teachers have been trained in NSF extended workshops and graduate courses and more than 180 Internet-based lesson plans have been created. Teacher surveys and student assessments have documented significant growth in problem-based learning, robotics, electronics, and engineering design.

Educators are encouraged to check out the extensive SPIRIT website at the following URL and to join us: www.ceen.unomaha.edu/Tek-Bots/SPIRIT2

There are 62 teams participating in the showcase this year, from area schools. The schools competing in the showcase this year are listed at the right.



CEENBot Teams

| School | Team Division | Team Name |
|-------------------------|---------------|---------------------------------------|
| Mary Our Queen | Elementary | Team Black Ops |
| | Middle School | Team 89 |
| | Middle School | Spicy Buffalos |
| | Middle School | Super Girls |
| | Middle School | Power Puffs |
| Swanson/Rockbrook | Elementary | Electronic Eliminators |
| Guardian Angels | Middle School | Bluejays |
| Trinity Christian | Elementary | TCS Androids |
| Lothrop | Elementary | Super Scientists |
| | Elementary | Science Superstars |
| | Elementary | BTR |
| | Elementary | Extreme Experts |
| | Elementary | Future Engineers |
| Gross | High School | Irrational |
| Oakdale | Elementary | Team Virus |
| Trinity Christian | Elementary | TCS Rovers |
| | Elementary | TCS Transformers |
| Hillside | Elementary | Cyborgs |
| LaVista Jr High | Middle School | LVJH Noble Brotherhood |
| | Middle School | LVJH Nerd Herd |
| Millard North | Middle School | MNMS #1 |
| | Middle School | MNMS #2 |
| | Middle School | MNMS #3 |
| Sunset Hills | Elementary | SS Brainiacs |
| Lewis & Clark Middle | Middle School | Blazer A |
| | Middle School | Blazer B |
| | Middle School | Blazer C |
| | Middle School | Blazer D |
| | Middle School | Blazer E |
| | Middle School | Blazer F |
| Hartman | Elementary | Alpha |
| | Elementary | Bravo |
| | Elementary | Charlie |
| Loveland & Prairie Lane | Elementary | The Creators |
| Prairie Lane | Middle School | Purple Ninja Penguins |
| Loveland | Middle School | Power Puffs |
| | Middle School | Super Hippo Earthquakes |
| | Middle School | The Flying Rainbow Ostrich Geek Squad |
| Bennington Jr-Sr high | Middle School | Badgerbots |
| Bennington Jr-Sr high | High School | Badger Blue |
| Columbus High | High School | Car Ramrod |
| Westside High | High School | Westside HS-1 |
| | High School | Westside HS-2 |
| | High School | Westside HS-3 |
| | High School | Westside HS-4 |
| | High School | Westside HS-5 |
| | High School | Westside HS-6 |
| Westside Middle | Middle School | WMS Warriors |
| St Columbkille | Middle School | |
| | Middle School | |
| Tara Heights | Middle School | Tara Tigers 1 |
| | Middle School | Tara Tigers 2 |
| | Middle School | Tara Tigers 3 |
| Westside Middle | Middle School | WMS Warriors |
| Beadle | Middle School | Bulldogs Alpha |
| | Middle School | Bulldogs Beta |
| | Middle School | Bulldogs Zeta |
| Trinity Christian | Middle School | TCS 1 |
| | Middle School | TCS 2 |
| | Middle School | TCS 3 |



STRATEGIC AIR & SPACE MUSEUM



Map Key

CEENBoT Showcase

Hangar A:

- 1 Practice Area
- 2 School Team Area
- 3 CEENBoT Games
- 4 Snack Area
- 5 Creativity Bots
- 6 Ball Course
- 7 Driving Maze
- 8 Team Driving Course
- 9 Autonomous Maze
- 10 Awards Area
- 11 Robotics Displays (on the Mezzanine)

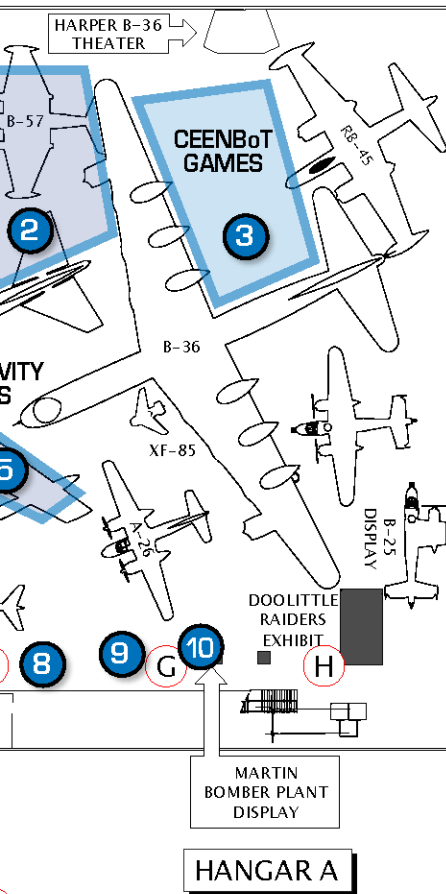

Schedule of Events

- 7:30 am Team Check-In
- 8:30 am Opening Ceremony (Atrium)
- 9:00 am FLL events begin (Hangar B)
- 9:00 am Jr. FLL Fair - Morning Session (Library)
- 9:30 am CEENBoT Showcase events begin
- 11:30 am Jr. FLL Award Ceremony - Morning Session (Library)
- 11:30 am Lunch begins (Restoration Hangar)
- 1:00 pm Jr. FLL Fair - Afternoon Session (Library)
- 1:30 pm Lunch ends
- 3:30 pm Jr. FLL awards ceremony - Afternoon Session (Library)
- 4:00 pm FLL Closing Ceremony (Hangar B)
- 4:00 pm CEENBoT Showcase Closing Ceremony (Hangar A)

Educational Presentations In The Theater, Main Floor

- 9:00-10:00 Time Warner Cable
Connect the Bots: An examination of how robotics inspires young people to become the problem solvers of tomorrow
- 10:00-10:45 AM Lockheed Martin
Robotics Engineering Projects Overview
- 10:45-11:15 AM UNMC Biomedical Engineering
The Use Of Simulation In Robotic Surgical Training
- 11:15-11:45 PM Break
- 11:45-12:45PM Time Warner Cable
Connect the Bots: An examination of how robotics inspires young people to become the problem solvers of tomorrow
- 12:45-1:15 PM Break
- 1:15-2:00 PM Lockheed Martin
Robotics Engineering Projects Overview
- 2:00-2:30 PM Avionics Interface Technologies
A Path For Local Students In Electronic Design For Aerospace
- 2:30-3:00 PM Raytheon
Engineering and Weather

FIRST LEGO League

Hangar B:

- 12 FLL Robot Game Tables
- 13 FLL Practice Table
- 14 FLL Pit Tables
- 15 FLL Volunteer Area
- 16 FLL Judging Area
- 17 Lunch area
- 18 Jr. FLL Fair
- 19 Registration & Info Tables
- 20 Educational & Sponsor Booths

FIRST® LEGO® LEAGUE

About the LEGO® Group

The LEGO® Group, a privately-held, family-owned company based in Billund, Denmark, is one of the world's leading manufacturers of high quality, creatively educational play materials for children. The company is committed to the development of children's creative and imaginative abilities, and its employees are guided by the motto adopted in the 1930s by founder Ole Kirk Christiansen: "Only the best is good enough." For more information, visit www.LEGO.com.

LEGO, MINDSTORMS and their respective logos are registered trademarks of the LEGO Group.

Jr.FLL

Jr. FIRST® League introduces younger children to the exciting world of science and technology. This program features a real-world challenge to be solved by research, critical thinking, construction, teamwork, and imagination. Guided by adult coaches, teams use LEGO bricks to build a model with a motorized part and develop a coordinating poster to illustrate their journey.

Children ages 6 to 9 get to:

- Design and build a challenge-related model using LEGO components
- Create a Show-Me poster and practice presentation skills
- Explore challenges facing today's scientists
- Discover real world math and science
- Begin developing employment and life skills
- Engage in team activities guided by FLL Core Values
- Choose to participate in events and celebrations coordinated by themselves or others in their community

About FIRST®

FIRST® (For Inspiration and Recognition of Science and Technology) was founded in 1989 by inventor Dean Kamen to inspire young people's interest and participation in science and technology. Based in Manchester, NH, **FIRST** is a 501(c)(3) not-for-profit public charity. **FIRST** is supported by a strong network of sponsors and volunteers.

FIRST provides the **FIRST** Robotics Competition (FRC) and FIRST Tech Challenge (FTC) for students in Grades 9-12 (ages 14-18), the **FIRST** LEGO League (FLL) for Grades 4-8 (ages 9 to 14), and the Junior **FIRST** LEGO League (Jr.FLL) for Grades K-3 (ages 6 to 9). For more information, visit www.usfirst.org.

FIRST and its logos are registered trademarks of US **FIRST**.

FLL

Children are immersed in real-world science and technology challenges as part of the **FIRST** LEGO League Program. Teams build LEGO-based robots and develop research projects. Through their participation, children develop valuable life skills and discover exciting career possibilities while learning that they can make a positive contribution to society.

Children ages 9 to 14* get to:

- Strategize, design, build, program and test a robot using LEGO MINDSTORMS technology
- Create innovative solutions for challenges facing today's scientists as part of their research project
- Apply real-world math and science concepts
- Develop employment and life skills including critical thinking, time management, collaboration, and communication while becoming more self confident
- Engage in team activities guided by FLL Core Values
- Become involved in their local and global community
- Choose to participate in official tournaments and local events coordinated by their community

* ages 9 to 16 outside the US and Canada.

FIRST LEGO League Teams

| Team Number | Team Name | Hometown |
|-------------|--------------------------------------|--------------------|
| 594 | Roving Monarchs | La Vista , NE |
| 674 | RoboFalcons | Omaha, NE |
| 675 | Relentless Robots | Omaha, NE |
| 737 | Mechanical Medics | Elkhorn, NE |
| 2587 | GI Lego Geeks | Omaha, NE |
| 3217 | West Harrison Brick Masters | Mondamin, IA |
| 3458 | Robotics for the Cure | Woodbine , IA |
| 3612 | Roadrunners 2.0 | Lincoln, NE |
| 3627 | Steve's Liver Lovers | Logan, IA |
| 3673 | Lego Adrenaline | Sergeant Bluff, IA |
| 3823 | Gear Heads | Blair, NE |
| 3824 | LegoC | Blair, NE |
| 3825 | Terminators | Blair, NE |
| 3826 | I.I.S.T.Y. | Blair, NE |
| 3897 | Montgomery County 4-H | Red Oak, IA |
| 4568 | Robot Dudes | Gretna, NE |
| 4852 | The Fighting Firebirds | Bellevue, NE |
| 5608 | York County 4-H: Green Dream Team | York, NE |
| 5609 | Rampaging Robots | Omaha, NE |
| 5652 | Brain Stormers | Lincoln, NE |
| 6553 | The Cyber Swags | Omaha, NE |
| 6556 | S.O.C.R. (South Omaha Club Robotics) | Omaha, NE |
| 6557 | Psi Bots | Omaha, NE |
| 6558 | Crazie Lego Monkeys | Carter Lake, IA |
| 6562 | Boys & Girls Clubs of Council Bluffs | Council Bluffs, IA |
| 6606 | Knights of the Square Table | Lincoln, NE |
| 6610 | The Pacemakers | Lincoln , NE |
| 6622 | Data Dragons | Omaha, NE |
| 6998 | Morton Panther Pack - Red Team | Omaha, NE |
| 6999 | Morton Panther Pack - Blue Team | Omaha, NE |
| 8214 | Marauders | Plattsmouth, NE |
| 8515 | GearNutz | Clay Center, NE |
| 8775 | KCHS Robotics | Kearney, NE |
| 9002 | Lewis Central Middle School Girls | Council Bluffs, IA |
| 9165 | Lego Maniacs | Omaha, NE |
| 9179 | 7 Guys and a Robot | Papillion, NE |
| 9713 | AuroraBot | Aurora, NE |
| 10018 | Pink Flamingos | Lincoln, NE |
| 10020 | Shout Outs | Lincoln, NE |
| 10341 | Robomaniacs | Lincoln, NE |
| 10344 | Random Rudolphs | Lincoln, NE |
| 10402 | Parkview Robotics | Lincoln, NE |
| 10437 | Timpte Terminators | David City, NE |
| 10440 | TOBOR | Kearney, NE |
| 10931 | York County 4-H Team Red | York, NE |
| 10932 | ! | Lincoln, NE |
| 10933 | Just Add Awesome | Lincoln, NE |
| 10934 | Flying Purple JPANS | Lincoln, NE |
| 11009 | Lego My Eggo | Clarinda, IA |
| 11069 | Clinton Elementary Girl Scout Team | Lincoln, NE |
| 11071 | Elliott Elementary Girl Scout Team | Lincoln, NE |
| 11501 | Aardbots | Lincoln, NE |
| 11783 | Robo Hobo's | Crete, NE |
| 11811 | Academy | Fremont, NE |
| 11840 | Glenwood | Malvern, IA |
| 11932 | Loup Basin Tech Kids on the Move | Ord, NE |
| 11933 | HTRS Titans | Pawnee City, NE |
| 11934 | RaiderBots | Mead, NE |
| 11935 | Sheridan County Terminators | Rushville, NE |

FLL in Nebraska

The FLL Planning Committee gives special thanks to **Time Warner Cable** for sponsoring **FIRST LEGO League**, including awards, audiovisual equipment and operation, volunteer hospitality, and volunteers.

We also thank all judges, referees, coaches, and all adult volunteers. You make FLL possible for Nebraska!

FLL Core Values

- We are a team.
- We do the work to find solutions with guidance from our coaches and mentors.
- We honor the spirit of friendly competition.
- What we discover is more important than what we win.
- We share our experiences with others.
- We display gracious professionalism in everything we do.
- We have fun.





Thank you Sponsors!.....

We proudly thank our sponsors for their support of the 2011 Nebraska Robotics Expo. Your generous contributions make this exciting competition possible and promote positive learning adventures for youth participants, leaders and fans.

PLATINUM SPONSORS

(\$10,000 +)



GOLD SPONSORS

(\$5,000 +)



SILVER SPONSORS

(\$1,000 +)



BRONZE SPONSORS

(\$500 +)

Raytheon

The Robotics Expo Committee would also like to thank the following sponsors for dedicating their employees' time and energy through volunteering at today's event.

Purple Ribbon Sponsor [200 hours]: Time Warner Cable

Red Ribbon Sponsor [50 hours]: Raytheon

Thank you!

The Nebraska Robotics Expo would like to thank its hosts, the Nebraska Air and Space Museum for the generous use of their space, material resources, and terrific ongoing support from their staff in helping to make this event a success.

SSW 5. Comparison of CEENBoT and TekBot Attributes

TekBot™

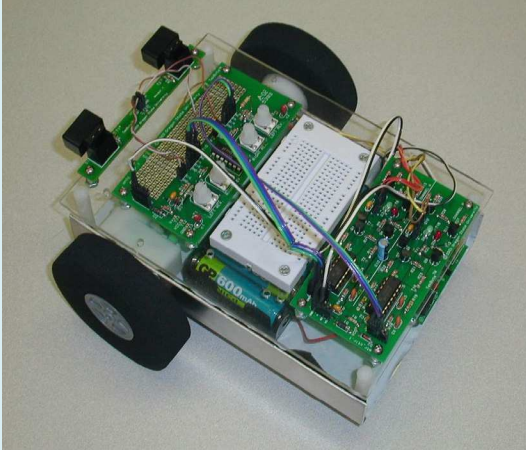

CEENBoT™

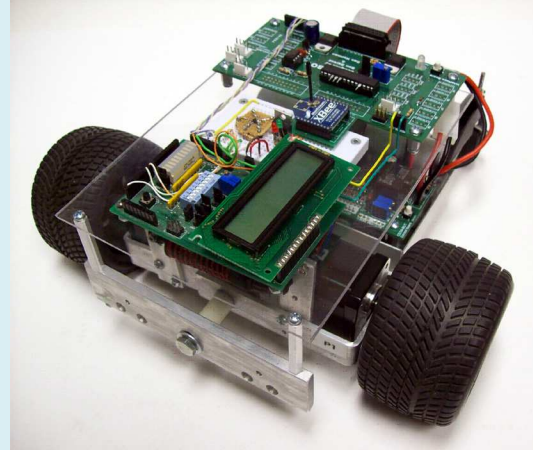

Attributes of the TekBot developed by Oregon State University: 5" by 7" footprint

- DC motors with plastic gear train and foam wheels
- Compact design
- Add-on boards allow for USB data logging, a USB video camera, and other development
- Prototype board for use by college students at both Oregon State University and University of Nebraska (to 2007)

Attributes of the CEENBoT developed by the University of Nebraska (CEEN): 6" by 8" footprint

- High-quality stepper motors for precision control
- Full suspension for traversing uneven terrain
- Larger capacity, quick-change power supply
- Interchangeable rubber drive tires
- Remotely controllable using the popular Sony PlayStation® controller
- Large prototype board for projects and more reliable connectors
- Serial-to-peripheral interface (SPI) to allow communication between multiple multiprocessors
- Amenable to K-16 educational space to meet needs at multiple levels

CEENBoT Features Under Development

- GPI and C++ interfaces
- Platform can accommodate GPS, laser diode, alternate wireless controls, different microprocessor systems, on-board video camera, and a robotic arm
- Compatible with Microsoft Robotics Studio
- Available in a number of configurations from kits to completed modules

SPiRiT Writing Team and Database Flowchart

Team 1: Lesson Draft Writers

Responsibility: Selecting topics from the list of algebra concepts, these writers create 2 or 3 page draft lessons. Each draft lesson includes: (include a *sample lesson*)

- 1) AEIOU "text" database version
 - Each of the 5 AEIOU boxes
 - Uses unique title of lesson
 - Submit to database
- 2) AEIOU "word" display version
 - A lesson in nicer word format
 - Same title as above
 - Suggested picture(s)
 - Suggested diagram(s)
 - Suggested chart(s)
 - Suggested worksheet(s)

Algebra Course Topics

- Algebraic expressions
- Signed numbers
- Operations on signed numbers
- Reciprocals and zero
- Removing grouping symbols
- Adding like terms
- Linear equations
- Word problems
- Inequalities
- Absolute value
- Exponents
- The distributive rule
- Factoring polynomials.
- Binomials and trinomials
- Factoring trinomials
- The difference of two squares
- Algebraic fractions
- Negative exponents
- Operations on algebraic fractions
- Equations with fractions
- Radicals
- Simplifying radicals
- Multiplying and dividing radicals
- Rational exponents
- Complex numbers
- Rectangular coordinates
- The Pythagorean distance formula
- The equation of a straight line
- The slope of a straight line
- Simultaneous linear equations
- Quadratic equations
- Variation

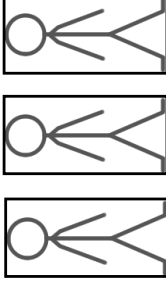

Leadership Team: This group monitors the two writing teams and continues to refine the database system and process.

"AEIOU Display" Database

Function: Displays lessons well
This database includes the more nicely displayed MSWord version of the lesson (or if necessary a pdf version). This database does not have switchable parts, but simply includes brief complete lessons, for when the user simply wants to display those versions, and perhaps to order them.

Text and Word versions of the developed lesson are linked by a unique title...

"AEIOU Pieces" Database

Function: Can swap pieces
This database (or part of the system) includes some lessons or topics where switching pieces make sense. In other words, for topics where multiple lessons have been submitted (such as slope), the user can mix and match AEIOU pieces of the lesson if desired for a separate text printout.

Functionality Notes:

1) For the AEIOU Display Database, a user can display nice looking, brief lessons in Word or pdf format that interest them on a particular algebra topic. If desired, a filter will suggest topics and lessons.

2) For the AEIOU Pieces Database, which works with selected lesson topics, the user is allowed to mix and match of component parts. For this database, the display is simple text, and it can be copied and pasted into other documents by the user as desired.

Note: All team members will be selected by application process, mailed out to all classes and SPiRiT participants.

Team 2: Lesson Editors

Responsibility: This group of team members carefully review the lessons and make editorial suggestions and fill in the missing pieces as they can. They will also review how the display works with the database components and how it appears to work.

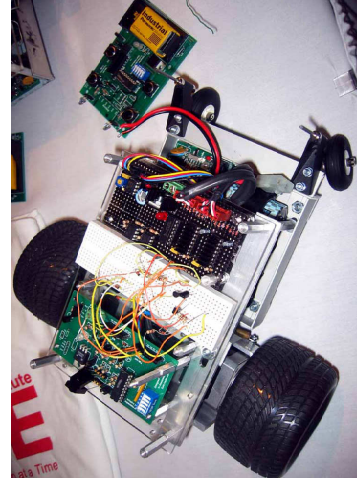
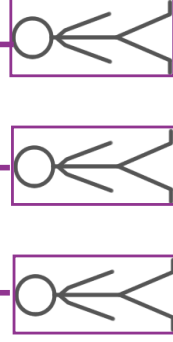

SSW 7. SPIRIT 2.0 Lesson: The Power Steering Is Out?!

Lesson Header

Lesson Title: The Power Steering Is Out?!

Draft Date: July 17, 2008, 2008

Author (Writer): Derrick A. Nero

Instructional Topic: Mathematics, Slope
 $m = \text{rise} / \text{run}$ and $m = (y_2 - y_1) / (x_2 - x_1)$

Grade Level: Middle

Content (what is taught):

- Use of coordinate planes and points
- Application of the mathematical formula $m = (y_2 - y_1) / (x_2 - x_1)$ or $m = \text{rise} / \text{run}$
- Measurement

Context (how it is taught):

- Coordinate points are identified and recorded
- The CEENBoT is driven from one coordinate point to another using the driving criteria, *Driving Criteria*: Travel only horizontally or vertically and make only one 90° turn.

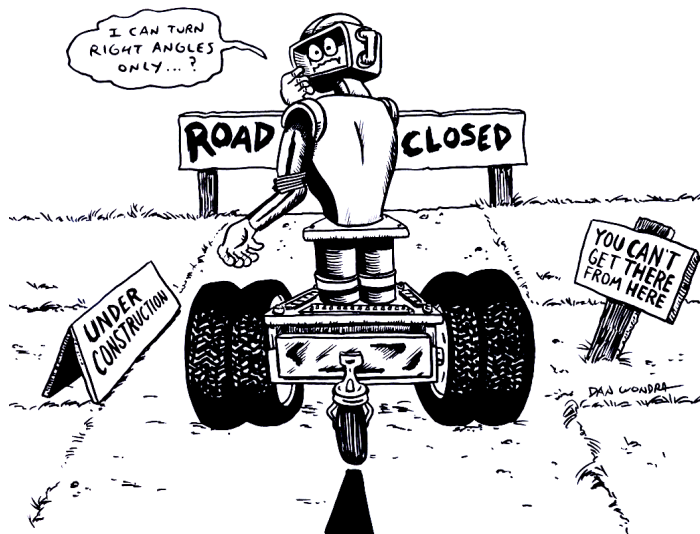

Activity Description:

In this lesson, students investigate how the slope of a line connecting two coordinate points is calculated. Students will select “locations” on a coordinate plane marked on the floor. Each student will record his/her “location” as a coordinate point. Pairs of students will be randomly selected to “travel” to one another’s “location” using the CEENBoT and the *driving criteria*. All students will record the horizontal and vertical distances traveled by the CEENBoT. The student pair will then travel in a straight path from one “location” to the other and will measure the path using a meter stick. Finally, students will calculate the slope of each pairing using the formula $m = \text{rise} / \text{run}$ or $m = (y_2 - y_1) / (x_2 - x_1)$.

Standards:

Science
A1, A2

Technology
A3

Engineering
A1, B1

Mathematics
A1, A3, D1, D2, E1, E3

Materials List:

CEENBoT
Student Data Sheet
Notebook

Masking tape
Meter sticks

ASKING Questions (The Power Steering Is Out?!)

Summary:

Students determine the best route to travel from one location to another.

Outline:

- Demonstrate the CEENBoT traveling on the coordinate plane that is marked on the floor.
- Drive the CEENBoT from one location to the other using many 90° turns.
- *Driving Criteria:* Drive the CEENBoT from one location to the other using only one 90° turn.

Activity:

The teacher will demonstrate driving the CEENBoT on the coordinate plane from one location to another. As students become interested, ask these questions:

| Questions | Answers |
|---|---|
| How many routes can be used to travel to either location? | Numerous routes (with no constraints) can be used to travel to either location. |
| How many routes can be used to travel to either location, using the <i>driving criteria</i> ? | Two routes (with the second being the opposite of the first) can be used to travel to either location using the <i>driving criteria</i> . |
| What is the quickest route from one location to the other? | A straight path is the quickest route from one location to the other. |

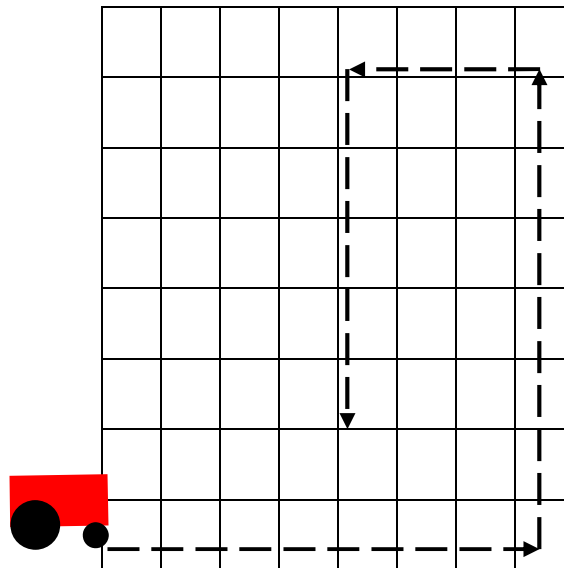

EXPLORING Concepts (The Power Steering Is Out?!)

Summary:

Students investigate the relationship between the horizontal, vertical, and diagonal distances traveled from one point to another, and describe the slope between points using rise and run.

Outline:

- Students will drive the CEENBoT on a coordinate plane that is marked on the floor.
- Student pairs will drive the CEENBoT from one location to another using only 90° turns.
- *Driving Criteria:* Drive the CEENBoT from one location to the other using only one 90° turn.
- Student pairs will drive the CEENBoT from one location to another using the driving criteria..
- Students will predict the number of units from the starting location to the 90-degree turn (Run).
- Students will predict the number of units from the 90-degree turn to the ending location (Rise).
- Students will predict the straight path distance from one location to the other (Distance).

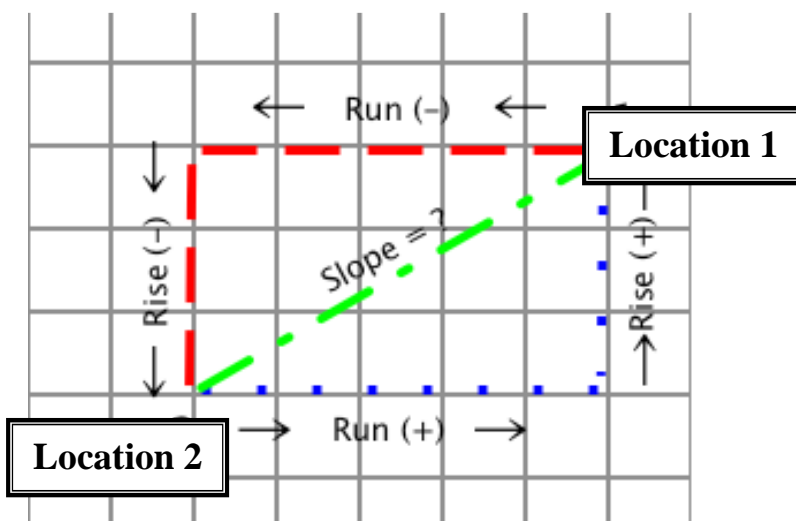

Activity:

In this lesson, students investigate how the slope of a line connecting two coordinate points is visualized. Students will select “locations” on a coordinate plane marked on the floor. Each student will name their “location” as a coordinate point. Pairs of students will be randomly selected to “travel” to one another’s “location” using the CEENBoT and the *driving criteria*. Students will name the horizontal and vertical distances traveled by the CEENBoT including the positive and negative sign on the value. The student pair will then travel in a straight path from one “location” to the other, and will describe the distance and features of the path and compare it to the path when using the *driving criteria*.

To provide formative assessments of the exploration, ask yourself or your students these questions:

1. Did students consider the direction, therefore the negative or positive sign of the value?
2. Did students predict the distances traveled to be identical between locations? both directions?
3. How did students predict the straight path distance from one location to the other (i.e., math computation or estimate)?

INSTRUCTING Concepts (The Power Steering Is Out?!)

Putting Slope in recognizable terms: Other words for slope are: steepness, pitch, grade, angle of elevation, angle of inclination/declination, and *rise over run*.

Putting Slope in Conceptual terms: Slope is a relationship between two rates (related rates) or a comparison of two distances (remember that rate is just a *distance* divided by a measure of time, $r = d/t$): the distance the bot travels in the y direction varies (or changes) as a **factor** (m) of the distance the bot travels in the x direction. So, some number (m) times x gives us y . Therefore, m (dist. Of x) = (dist. Of y). If we solve for the variable m by dividing both sides of the equation by (dist. Of x), we get a related rate (slope). This is also called *rise over run*.

Putting Slope in Mathematical terms: We could also call the distance traveled in the y direction the *change in distance* of y or the difference in the y -coordinate values of two points. We could call the distance traveled in the x direction the *change in distance* of x or the difference in the x -coordinate

values of the same two points. This gives us a formula: $M = \frac{\Delta y}{\Delta x}$ (difference in y values over the difference in x values or, delta y divided by delta x). When we get to *calculus*, we simplify by saying,

$$m = \frac{dy}{dx} .$$

Putting Slope in Process terms: Algebraic computation of slope: $m = \frac{y_2 - y_1}{x_2 - x_1}$. Provide examples of calculating slope between points. Be sure to include examples and explanation of negative value slopes.

Putting Slope in Applicable terms: Randomly angle the bot, drive it for three seconds from a given point, measure the *vertical* and *horizontal* components, and define the slope.

ORGANIZING Learning (The Power Steering Is Out?!)

Summary:

Students investigate the relationship between the horizontal, vertical, and diagonal distances traveled from one point to another, and calculate the slope between points using the slope formula or rise and run.

Outline:

- Student pairs will drive the CEENBoT from one location to another using the driving criteria.
- *Driving Criteria:* Drive the CEENBoT from one location to the other using only one 90° turn.
- Collect data as student pairs travel to one another's locations
- Data includes the coordinate points, and horizontal (run), vertical (rise), and diagonal distances.
- Fractions should be expressed in reduced form.

Activity:

In this lesson, students calculate the slope of a line connecting two coordinate points. Students will select "locations" on a coordinate plane marked on the floor. Each student will record his/her "location" as a coordinate point. Pairs of students will be randomly selected to "travel" to one another's "location" using the CEENBoT and *driving criteria*. All students will record the horizontal and vertical distances traveled by the CEENBoT. The student pair will then travel in a straight path from one "location" to the other and will measure the distance of the path using a meter stick. Finally, students will calculate the slope of each pairing using the formula $m = \text{rise} / \text{run}$ or $m = (y_2 - y_1) / (x_2 - x_1)$.

Student Worksheet

The Power Steering Is Out!
Student Data Sheet

Directions: Each student will select a "location" on the coordinate plane. Record each location as an ordered pair in the chart. Draw the robot from one location to the other using one 90-degree angle. Measure and record the horizontal and vertical distances traveled. Look at the example below the picture.

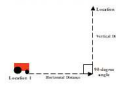

| Student 1's Location | Student 2's Location | Vertical Measurement | Horizontal Measurement | Slope Calculation |
|----------------------|----------------------|----------------------|------------------------|------------------------------------|
| (2, 3) | (2, 6) | 3 | 0 | $\frac{6-3}{2-2}$ $\frac{3}{0}$ |

Your Turn!

| Student 1's Location | Student 2's Location | Vertical Measurement | Horizontal Measurement | Slope Calculation |
|----------------------|----------------------|----------------------|------------------------|-------------------|
| | | | | |
| | | | | |
| | | | | |
| | | | | |
| | | | | |

UNDERSTANDING Learning (The Power Steering Is Out?!)

Summary:

Students write essays about the application of $m = \text{rise} / \text{run}$ or $m = (y_2 - y_1) / (x_2 - x_1)$.

Outline:

- Formative assessment questions asked during the learning activity about slope and its meaning.
- Summative assessment essay questions about slope and its application.

Activity:

Formative Assessment

As students are engaged in learning activities ask yourself or your students these types of questions:

1. Were the students able to apply either formula for slope?
2. Can students explain the meaning of slope?

Summative Assessment

Students will complete the following essay questions about the distance-rate-time formula:

1. Calculate the slope of the line formed by the student's home and the local shopping mall.
2. Write a story involving the path of a rogue robot determined to find its creator and how detectives found it based on its known locations.
3. Describe how you can tell the positive or negative value of slope by looking at the location of two points on a coordinate plane.

Student Worksheet

| The Power Steering Is Out Essay Rubric | | | |
|---|---|--|--|
| | 5 Points | 4 Points | 3 Points |
| Essay 1 Calculation of Slope | The calculation of slope is correct with all work shown. The work shown is detailed and written out step-by-step. | The calculation of slope is correct. Some or all of the work is shown but is not as detailed. | The calculation of slope is incorrect. Some (or no) work is shown. |
| Essay 2 Rogue Robot Story | The story is detailed and includes mathematical vocabulary (slope, rise, run, etc.) throughout. The calculations are correct with all work shown. | The story is somewhat detailed and includes some mathematical vocabulary. The calculations are correct but the work is not as detailed. | The story lacks detail and includes little (or no) mathematical vocabulary. The calculations may or may not be correct and the work is incorrect or not shown. |
| Essay 3 Positive and Negative Slope | The explanation is clear and uses mathematical vocabulary (slope, rise, run, etc.). Examples (drawings) are shown with a clear explanation of each. | The explanation is somewhat clear and includes some mathematical vocabulary. Examples are included, but may not be as clearly explained. | The explanation is not clear and includes little (or no) mathematical vocabulary. Examples may be included but are incorrect and/or not explained. |

© 2009 Board of Regents University of Nebraska

The Power Steering is Out?! Student Data Sheet

Directions: Each student will select a “location” on the coordinate plane. Record each location as an ordered pair in the chart. Drive the robot from one location to the other using one 90-degree angle. Measure and record the horizontal and vertical distances traveled. Look at the example below the picture.

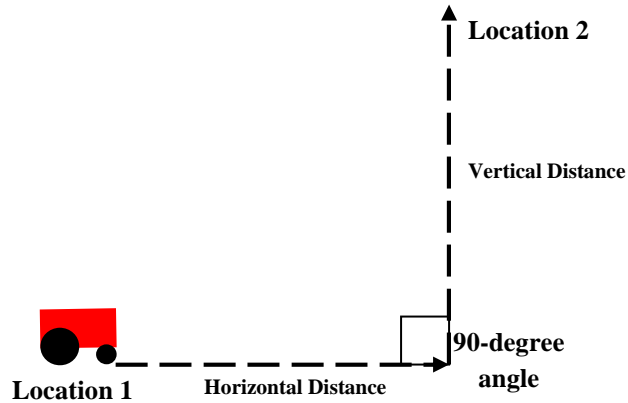

| Student 1's Location | Student 2's Location | Vertical Measurement | Horizontal Measurement | Diagonal Measurement | Slope Calculation |
|----------------------|----------------------|----------------------|------------------------|----------------------|--|
| (1, 2) | (4, 6) | 4 | 3 | 5 | $\frac{6-2}{4-1} = \frac{4}{3} = 1.33$ |

Your Turn!

| Student 1's Location | Student 2's Location | Vertical Measurement | Horizontal Measurement | Diagonal Measurement | Slope Calculation |
|----------------------|----------------------|----------------------|------------------------|----------------------|-------------------|
| | | | | | |
| | | | | | |
| | | | | | |
| | | | | | |

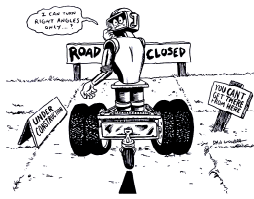

The Power Steering Is Out

Essay Rubric

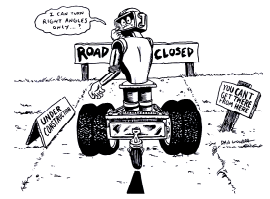

| | 5 Points | 4 Points | 3 Points |
|--|---|---|---|
| <p>Essay 1</p> <p>Calculation of Slope</p> | <p>The calculation of slope is correct with all work shown. The work shown is detailed and written out step-by-step.</p> | <p>The calculation of slope is correct. Some or all of the work is shown but is not as detailed.</p> | <p>The calculation of slope is incorrect. Some (or no) work is shown.</p> |
| <p>Essay 2</p> <p>Rogue Robot Story</p> | <p>The story is detailed and includes mathematical vocabulary (slope, rise, run, etc.) throughout. The calculations are correct with all work shown.</p> | <p>The story is somewhat detailed and includes some mathematical vocabulary. The calculations are correct but the work is not as detailed.</p> | <p>The story lacks detail and includes little (or no) mathematical vocabulary. The calculations may or may not be correct and the work is incorrect or not shown.</p> |
| <p>Essay 3</p> <p>Positive and Negative Slope</p> | <p>The explanation is clear and uses mathematical vocabulary (slope, rise, run, etc.) Examples (drawings) are shown with a clear explanation of each.</p> | <p>The explanation is somewhat clear and includes some mathematical vocabulary. Examples are included, but may not be as clearly explained.</p> | <p>The explanation is not clear and includes little (or no) mathematical vocabulary. Examples may be included but are incorrect and/or not explained.</p> |

SSW 8. Sample CEENBoT Game

Descriptive Game Name: BUMP BOT NAVIGATION

Author: Betsy Rall, Matt Bills, Jennifer Higgins, Brian Moeller

Game Brief Description: In this game, students will operate their CEENBoT in Bump-Bot mode through a course. The students will activate the sensors at the front of the CEENBoT to cause it to change directions in order to successfully get through the course.

Game Area Picture/Diagram and Materials: A CEENBoT course should be created on the floor with tape and cones (or other obstacles). The course should contain corners and curves that necessitate the turning of the CEENBoT.

- A CEENBoT for each competitor
- Cones and/or other obstacles
- Tape or other material that would provide an outline of the course on the floor
- Stopwatch for timing the CEENBoT as it drives through the course.

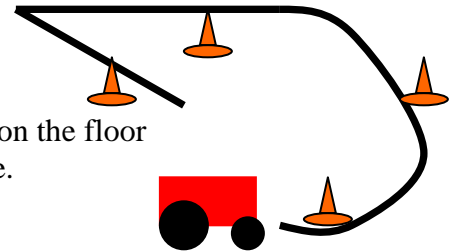

Rules:

1. Students will play in pairs. One person will ‘drive’ while the other uses the stopwatch to time and keep track of penalties.
2. The ‘driver’ may use any part of his or her body to activate the sensors at the front of the CEENBoT and cause it to change direction while traveling through the course.
3. Any redirection of the robot using anything other than the sensors will result in a 20 second penalty. This penalty will be added to the total time.
4. Additional penalties can be decided upon before going through the course (i.e. If the CEENBoT knocks down an obstacle while going through the course, a certain number of seconds could be added to the total time.)

Scoring:

Each student will complete the course using the CEENBoT in Bump-Bot mode.

Game Suggestions:

1. Have each pair of students create a course and test it using a CEENBoT. Make any necessary modifications to the course before the competition starts. For example, when students test the course, they might find areas that need to be widened, etc.
2. Let each student have a second-chance at the course and take the better time or an average of both times.

Learning within the Game:

Students should gain some creative experience in creating a course. Students should also gain some insight into geometry when directing the CEENBoT. Students should gain an understanding of how the CEENBoT moves in Bump-Bot mode.

CEENBoT 324 Board

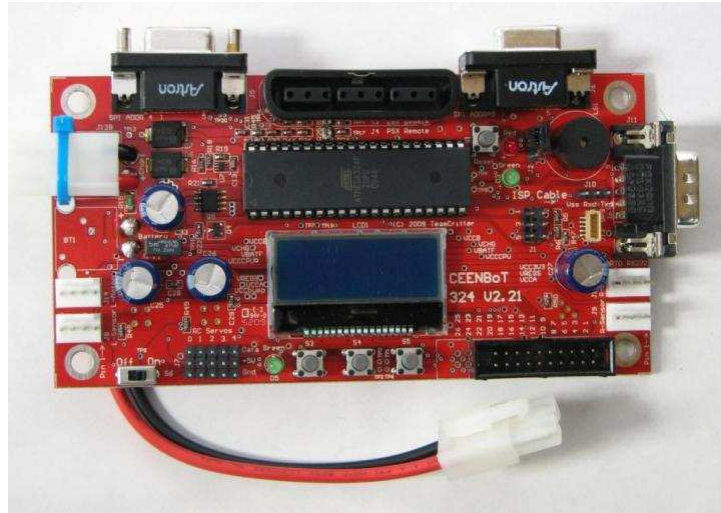

UNIVERSITY OF
Nebraska

THE PETER KIEWIT
INSTITUTE
Information Science, Technology & Engineering

CEENBoT 324 Board

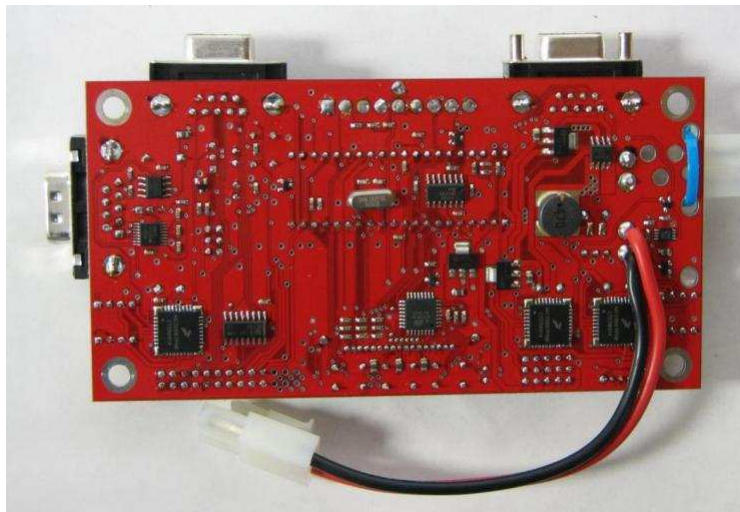

UNIVERSITY OF
Nebraska

THE PETER KIEWIT
INSTITUTE
Information Science, Technology & Engineering

CEENBoT 324 Board with only preloaded parts

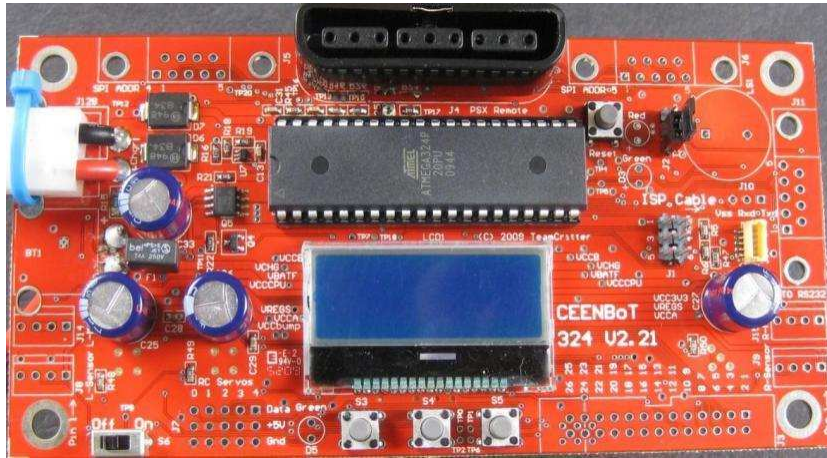

UNIVERSITY OF
Nebraska

THE PETER KIEWIT
INSTITUTE
Information Science, Technology & Engineering

CEENBoT 324 Board Computer & Electronics Engineering

- If the Parts Map has not been printed, access it [here](#).
- Sort all of your components placing them on the appropriate location on the Parts Map.

CEENBoT 324 Board Computer & Electronics Engineering

- Assemble the circuit using the following step-by-step directions.

CEENBoT 324 Board Computer & Electronics Engineering

- Always wear safety glasses when soldering and cutting component leads.
- Double check that you have the correct component and that is oriented correctly – it takes 15 seconds to check but 15 minutes to fix a mistake.

Insert the switches. The pin-outs are rectangular so there are two ways they can be oriented. Either way will work.

4: S1, S3, S5, S5
SPST Switch

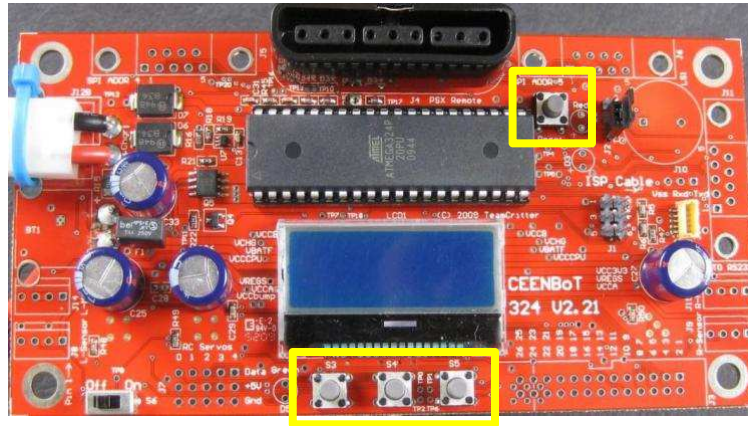

Insert the red LED. The longer lead goes into the hole with the + symbol. If you put it the other way, it won't work.

1: D2 Red LED
Long Lead is +

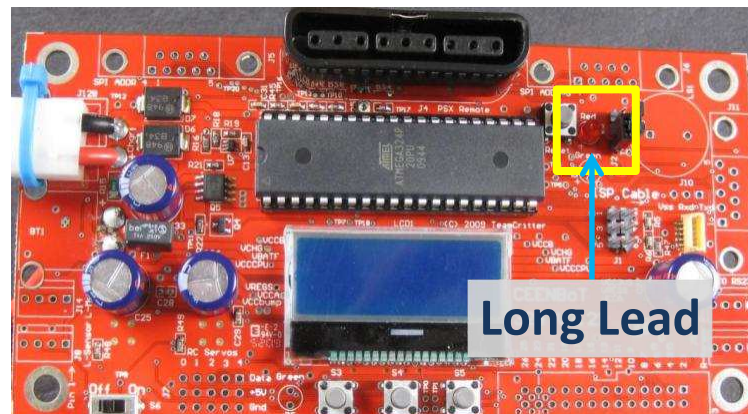

Insert the green LED's. The longer lead goes into the hole with the + symbol.

2: D3, D5 Green LED
Long Lead is +

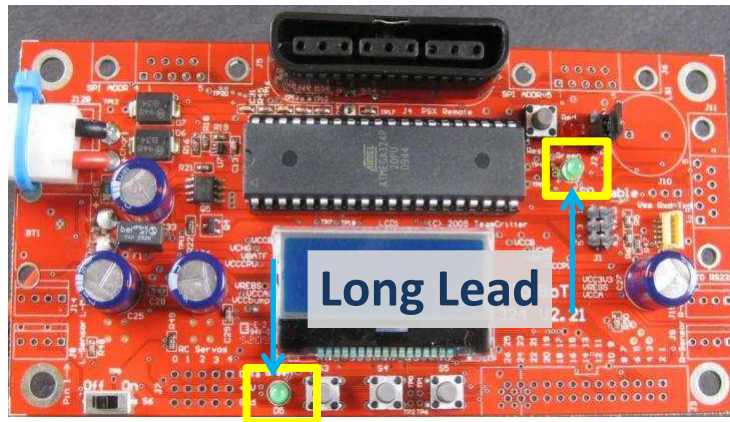

Insert the 3 pin male header. **The short end of the leads goes into the board.** Only solder one pin. Check that it is seated properly and solder the remaining pins. See video **Soldering Male Headers**

1: J10 1X3 Male Header

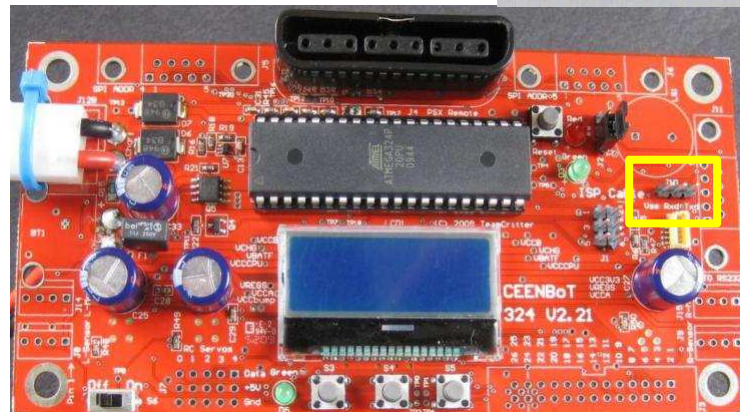

Insert the five male headers. See the next slide on how to keep them aligned while soldering. **Solder the SHORT end.**

5: J7 1x3 Male Header
Solder **SHORT** end

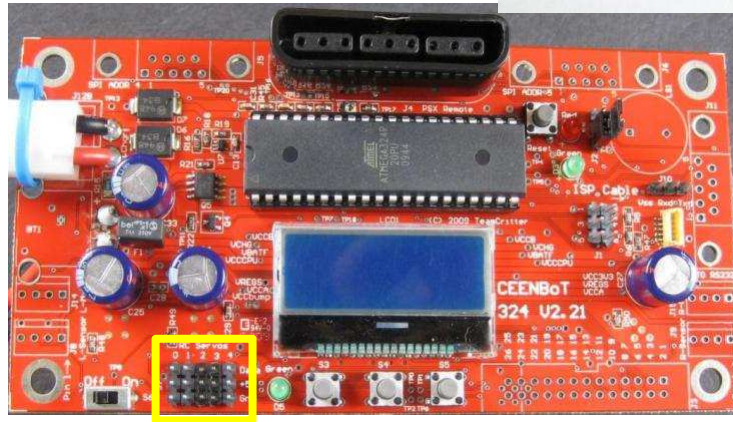

It is difficult to keep all pins parallel and vertical. Place a female header (the instructor will have some) on the middle row of pins. This will keep all pins aligned and you can use your finger to make sure they are seated properly and are vertical.

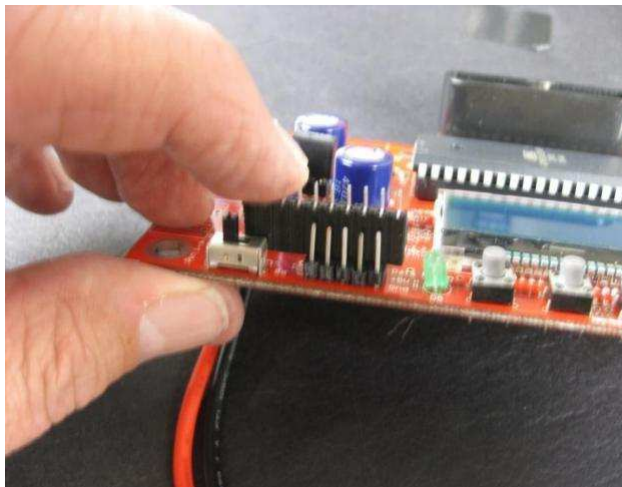

Insert and solder the male latched connectors. The short end goes into the circuit board. The white plastic lip aligns with the stripe on the board.

4: J8, J9, J14, J15 4 Pin Male

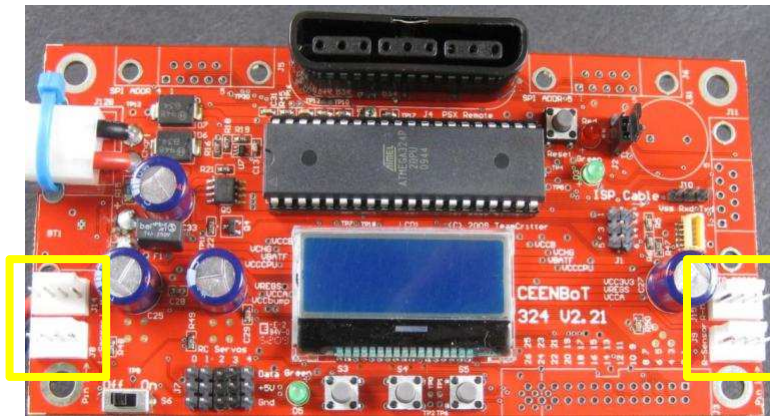
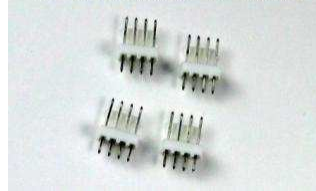

Insert the 20 pin male connector. Make sure that it aligns with the outline on the board, that the notch is toward the middle of the board and no pins are bent under.

1: J3 Male Connector - 20 Pin



Make sure to align with outline on board

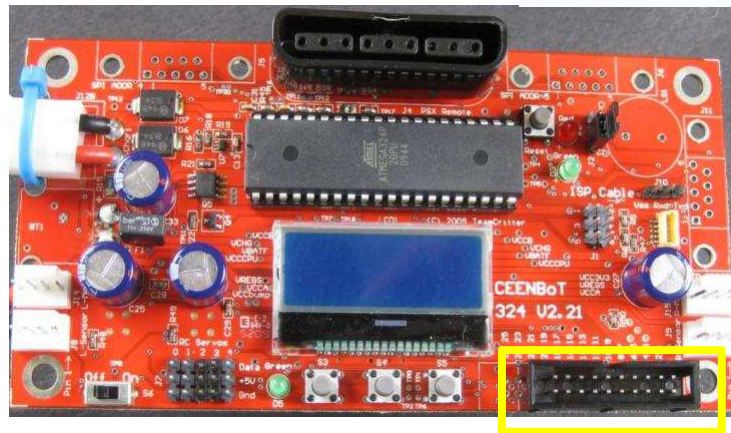

Solder the speaker. The lead marked + goes into the hole with the square pad. You may need to spread the leads a little to make it fit.

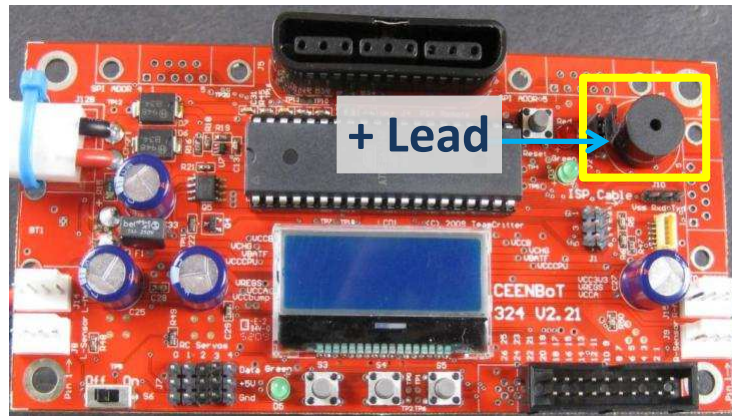

Inserting the DB9 connectors can be tricky. Make sure all pins are all straight before trying to insert them into the board. After the component is inserted, double check that none of the pins were bent over and that they have all come through the board.

1: J11 DB9 Male



Insert the two DB9 female connectors using the same technique used for the male connector.

2: J6, J6 DB9 Female

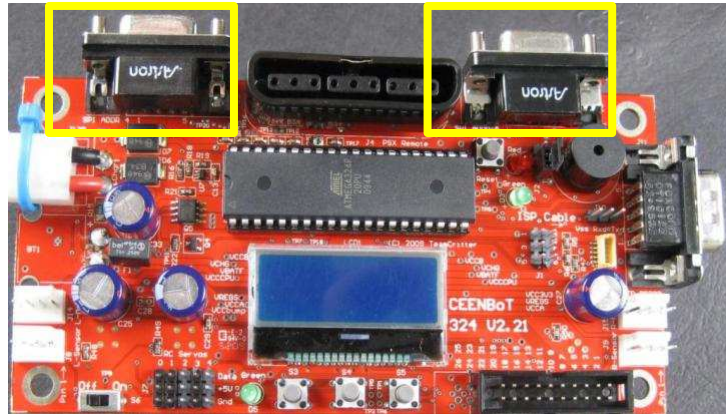

- Have the instructor check your completed board for any obvious soldering mistakes. He will also apply power to test it for proper operation.

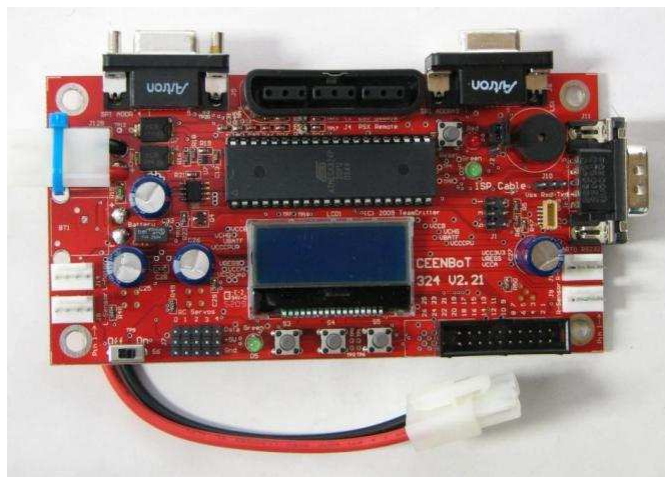

Engineering Notebook

Engineering Notebook
Number

First Name

Last Name

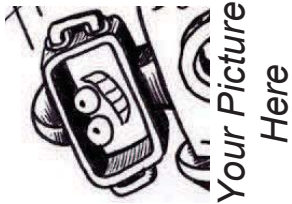

Medical



Manufacturing



Construction



Agricultural

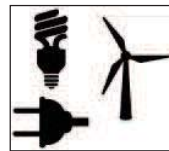

Energy &
Power

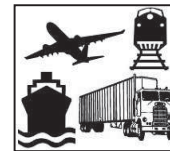

Transportation



Information &
Communication

Rules

Be Safe

- Follow Lab Safety Rules
- Think before you act
- Hand objects – never throw

Be on Time

- Coming to class
- Handing in work

Follow Instructions

- Use the Social Skill by looking at the person/task, saying o.k. and doing the task immediately
- Keep Following Instructions the entire class time

Cooperate

- Use appropriate voice levels
- Respect partners – share, take turns, help, but do your own work
- Respect guests and guest teachers
- Be mature - monitor your own behavior
- Use your Social Skills

Safety Rules

- 1) Wear safety glasses at all times while using tools and equipment.
- 2) Keep all loose clothing and long hair tied back.
- 3) Use tools, materials and equipment for their designed purpose.
- 4) Do not talk to a person operating equipment.
- 5) Keep your work area clean and clear.

~Safety is EVERYONES' responsibility~

Partner/Group Reminders

- When someone talks, the other(s) listen.
- Allow everyone time to talk.
- Use only positive voice tones and comments – use your manners!
- Keep voices at low levels.
- Walk your chairs to the group area.
- Practice your Employability Skills. (see back cover)

Daily Instructions

- 1) Put belongings on shelf (zip trapper) and bring Assignment Notebook (handbag).
- 2) Use restroom/get a drink/get forms signed, etc.
- 3) Read and follow instructions on message board.
- 4) Read make up work if you have been absent.
- 5) Pick up Engineering Notebook and immediately follow message board instructions.
- 6) Sit down, put Name Badge on. If needed pick up computer - if needed, carefully wash/put safety glasses on (try to keep lenses scratch free).
- 7) Take inventory and report anything missing or damaged items. Use tools and materials only for the assignment – do not waste materials.
- 8) Sit with your knees under the workstation, facing the center. If it is more than a step – get up and walk.
- 9) Talk only with your workstation partner at a low level.

Closure Instructions

- 1) Make Assignment Notebook entry.
- 2) Restart/shut down – push computer under shelf or put away.
- 3) Return everything to its proper place.
- 4) Take inventory. Report any missing or damaged items.
- 5) Brush workstation dust/etc. into waste can – wipe down if needed.
- 6) Bookmark Engineering Notebook page with Name Badge.
- 7) Sit with your knees under your workstation facing the center and wait to be dismissed.

Lab Reminders

- To ask a question, use call lights so you can continue to work – on no call light days, a teacher will come around.
- Keep work area clean and clear. Keep computer pushed under shelf when working on products.
- When using computer nothing touches the screen and only your fingers touch the keyboard. Move computer by the base.
- Use only your period drawer and keep your hands off others' work.
- While waiting in line to use equipment, stand three feet back – behind line – no more than two people in line.
- Sand and file over a waste can.

Notes/Sketches/Questions/Thoughts

What is the Purpose of this Notebook?

This Engineering Notebook will be used to record your progress, ideas, notes, sketches questions, and thoughts. It is your evidence of the work you have completed.

This notebook has all the information you need to be successful in class. It will be kept in the classroom. If you need to take it home, you will need to _____

Why an Engineering Notebook?

Engineers use an Engineering Notebook to record ideas, inventions, experimentation records, observations, and all work details. Careful attention to how they keep their Engineering Notebook can have a positive impact on the patent outcome of a pending discovery, invention, or innovation.

How do I keep an Engineering Notebook?

1. Write NEATLY - anyone should be able to read it.
2. Write down EVERYTHING AS IT HAPPENS.
 - If it is not documented, it did not happen
 - If you write it the next day, it did not happen.
3. Use BOTH sides of a page.
4. Date each entry in chronological order.
5. Clearly separate each day's entry by drawing a line under the entry.
6. Entries should include enough information so someone else could successfully duplicate your work.
 - Label figures and sketches. Keep sketches up-to-date – make changes as they happen.
 - Use complete sentences – a complete sentence is a complete thought that begins with capitalization and ends with a form of punctuation.
7. Draw a single line through any errors and enter the correct information nearby . . . it is o.k. to erase sketches
8. Never leave blank spaces - simply "X" out any blank spots.
9. Never, under any circumstances, remove pages from your notebook.
10. If you add pages, tape or glue it onto a page in your notebook. Clearly label and date it.

Reading a Ruler

If you have not memorized what each line on the ruler measures, use the rulers below to help you measure.

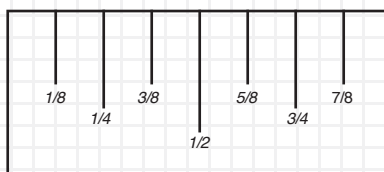

8 Division Ruler

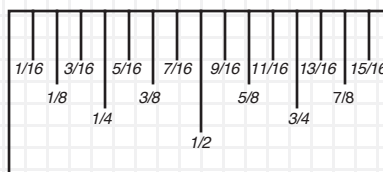

16 Division Ruler

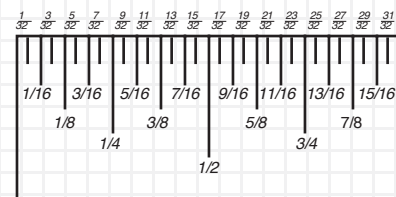

32 Division Ruler

Notes/Sketches/Questions/Thoughts

Date:

Design Brief Name Badge

Situation/Challenge

In work environments, people need to wear name badges. This may be for identity, security or just so someone can call you by your name. In this class, you will change partners many times. You will be required to wear a name badge, so we can learn each other's names. This badge will remain in the room and be stored in your Engineering Notebook.

Criteria and Constraints

- Follow the procedure to complete your name badge.
- You may only use the material and tools listed.



Tools, Materials, Equipment

- computer
- printer
- laminator
- laminating pouch
- scissors
- badge clip

Procedure

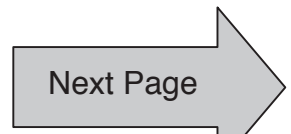
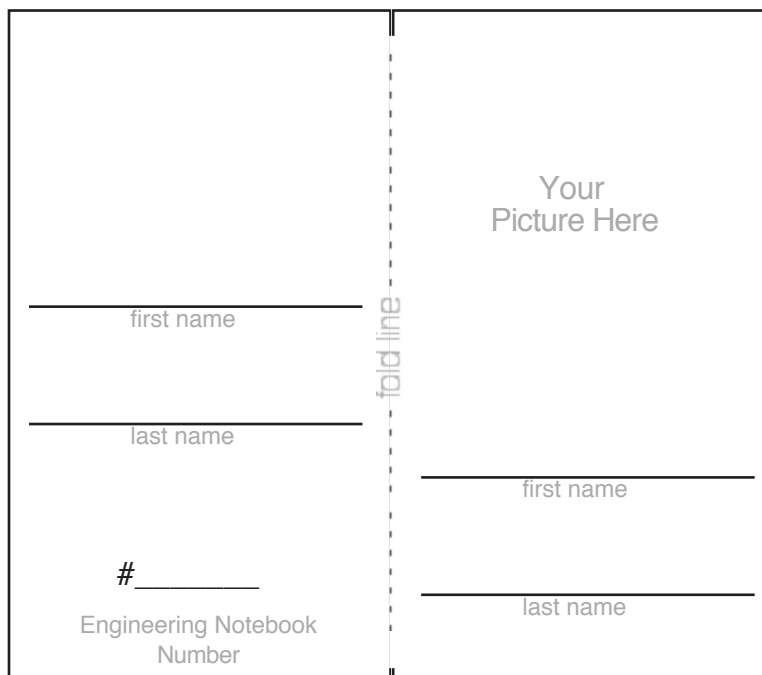
1. Follow this procedure to make your name badge.
2. Identify the problem by re-reading the situation/challenge.
3. You will not be doing any Research for this situation/challenge.
4. The possible solutions have already been Developed for you.
5. The best solution was Selected for you.
6. Construct your name badge by following the steps below.
 - a. On the desktop of your computer open the **name badge** template. If it asks, click on OPEN A COPY. It will look like the graphic below:



- b. Begin with the area below the words “Your Picture Here.”
 - c. Click on the  tool - click above the line and type your **first** name.
 - d. Click on this name and move it to the correct location.
 - e. Click the  tool - now click on your name - make your **first** name as big as possible but still fits on the line by changing the size of the text - under FORMAT
 - f. You may need to make your text box larger by clicking on one of the boxes and dragging it out.
 - g. Move name close to the line.
 - h. Do the same for your last name.
 - i. Now do the other side of the name badge.
 - j. Type your three-digit Engineering Notebook number, change the text size and move it into place.
 - k. Have your partner do the steps above.
 - l. Turn on call light (light switch located at your workstation) and have it checked.
 - m. Print the document.
 - n. Cut out name badge and fold in half along “dashed” line.
 - o. Locate your picture and cut it out along the outside edge.
 - p. Return scissors and recycle paper waste in the blue recycle bins.
 - q. Open laminator pouch, place folded name badge - picture UP - towards punched hole.
 - r. Place picture (right side up) on top of picture box and carefully close the laminating pouch.
 - s. Place “**closed side**” of laminating pouch into laminator - push gently until the machine rollers take the pouch - it will roll out the back.
 - t. Return to workstation and attach the badge clip to your laminated name badge.
7. Test and Evaluate as well as Communicate who you are by clipping your name badge on your shirt. In this class we will wear our name badge where our heart is located.
 8. You will not Redesign or Improve this product. Close your document without saving it.
 9. Turn to page 2 in your Engineering notebook and draw a line under your last entry. Then, under the line, enter today’s date.
 10. CHOOSE either website below or do both.
 - a. Begin by opening up the Internet on your computer.
 - b. In your Engineering Notebook, after today’s date, practice sketching. Your sketches do not have to be very big, but you want to be able to add details to it.
 - Go to bruceblitz.com - select Cartooning Tips - start by selecting the past tip CARTOON LION - sketch it using the steps. Now choose any of the tips and sketch them.
 - Practice basic sketching skills at:
<http://web.mit.edu/2.009/www/resources/sketchingTutorials.html>
 When the page loads, begin by selecting one of the sketching skills. Follow along with the video sketching in your Engineering Notebook. If you finish one go to the next.

Assessment

This assignment will be recorded when it is completed correctly. You will receive an “X” to indicate you completed it.

If the computers or printer are not working – a copy of this Design Brief will be provided and you will use the graphic in your Engineering Notebook. Follow the Design brief through step 5 and substitute the paragraph below for steps 5a to 5m.

On the graphic, write your **first** and **last** name as large as possible on the lines. Do this on both sides of the name badge. Then write your three-digit Engineering Notebook number on the line. Turn on your call light and have it checked. Now go back to step 5n, and follow the procedure.

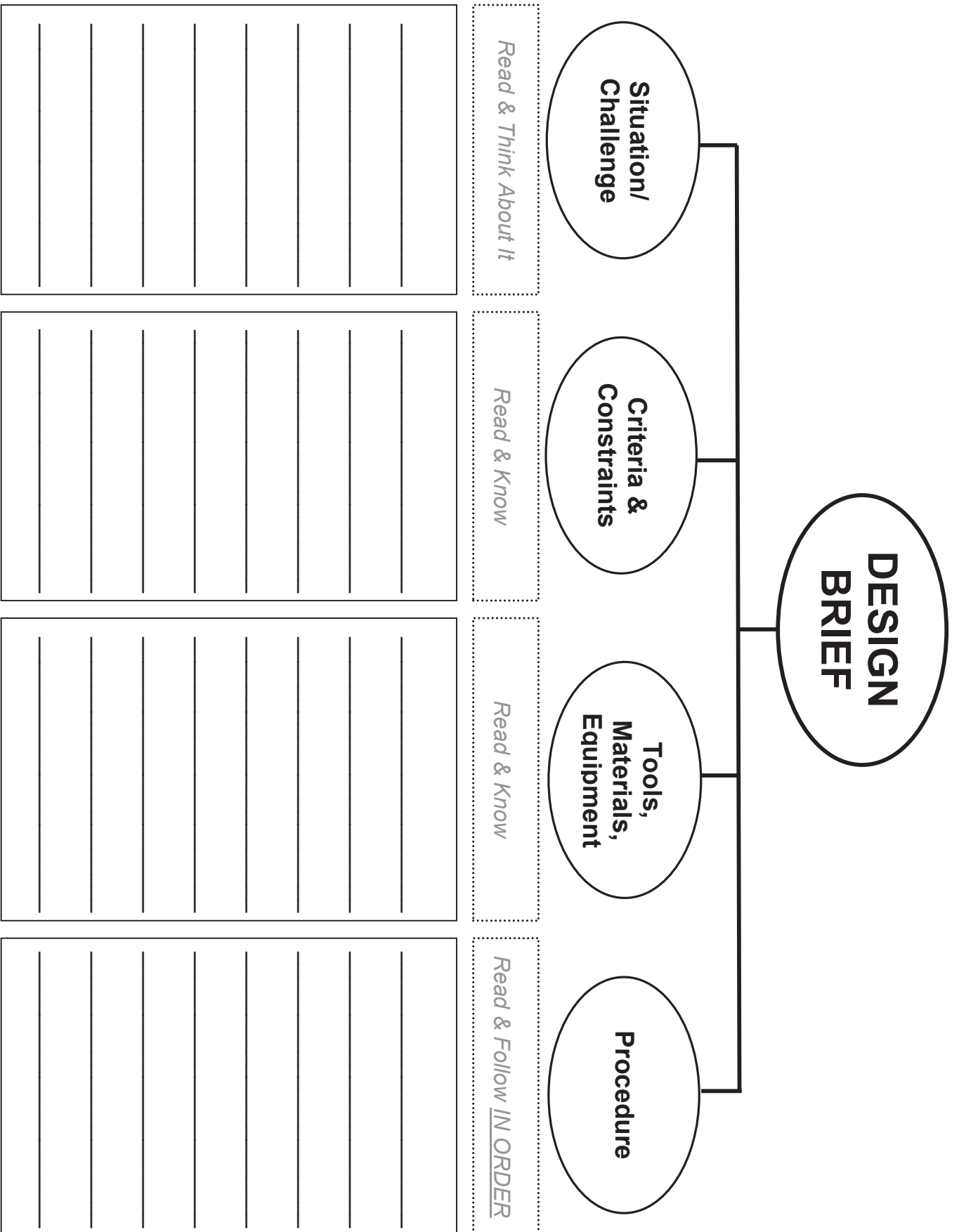

Design Brief

Flat to 3D

Situation/Challenge

This challenge will help you understand how a flat, 2-Dimensional image can become a 3-Dimensional object. It will also give you background information for solving future challenges. Your challenge is to label a flat image and make it into a 3-Dimensional object.

Criteria & Constraints

- Scissors may only be used for cutting the paper.
- Use the handle of your scissors and go over the fold lines – this will give you nice creases. *See picture below on how to do this.*

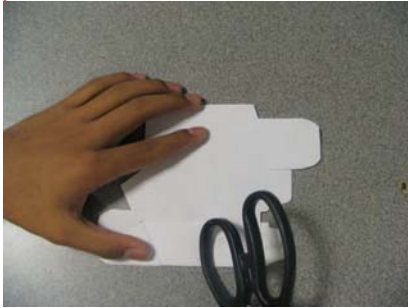

- Use very little glue.
- Recycle all paper scraps.
- Complete this design brief by due date.

Tools, Materials, Equipment

- Computer
- *Technology: Design and Applications* textbook
- Scissors – an extra pair of scissors for your partner are located at the Tools, Materials, Equipment area in your zone
- Pencil
- Very little glue

Procedure

1. **Identify** the problem by re-reading the situation/challenge. In your Engineering Notebook, restate the problem in your own words using a complete sentence.
2. **Research** –
 - a. From your Technology Textbook (index), look up the answer to this question – What is an isometric drawing? Think . . . How can I put this answer in my own words? Write your answer in a complete sentence in your Engineering Notebook.
3. The possible solutions have already been **Developed** for you.
4. **Select** one of the “boxes” from the Appendix C section (C-1, C-2, C-3, C-4) of your Engineering Notebook.
5. **Construct** your box by following the steps below . . .
 - a. Study the isometric (3D) and flat (2D) drawings
 - b. Label the views (top-front-side-right-left, etc.) on the isometric drawing
 - c. Label the views on the flat drawing – be sure to label the flaps
 - d. On the bottom view of the flat drawing, write your name and Engineering Notebook number
 - e. Cut your box out of your Engineering Notebook along the dashed lines
 - f. Cut out your box along the solid lines

- g. Fold and unfold along each dashed lines – use scissor handle to crease lines
 - h. Fold and shape the box to look like the isometric drawing
 - i. Using very little glue – glue flaps but do not glue the box shut
6. **Test and Evaluate** your box by comparing it to the criteria and constraints.
 7. **Communicate** the solution by showing the folded box to your partner – point to and name each of the sides.
 8. You will not **Redesign** or improve this product.
 9. When you are finished, in your Engineering Notebook, sketch a 3D object at your workstation.
 10. Now sketch what it would like if it were flat.
 11. Select another box and repeat steps 5 through 7.
 12. You will now design your own box.
 - a. Think of a PRODUCT and how it could be packaged.
 - b. Write the name of your product in your Engineering Notebook.
 - c. Sketch 3 creative ideas as to how you would package this product.
 - d. From your sketches, select the most creative box and circle it.
 - e. Make a more detailed 3-Dimensional sketch of this box/package.
 - f. Now locate a piece of scrap paper and draw the same box/package flat – include flaps and dashed lines for folding.
 - g. Cut out your box along the solid lines.
 - h. Fold and unfold along each dashed lines – use scissor handle to crease lines.
 - i. Fold and shape the box to look like the isometric drawing.
 - j. Using very little glue – glue flaps but do not glue the box shut.
 13. Now look at other ways to turn Flat images into 3-Dimensional images. Type in one or both of the following addresses:
 - <http://www.papertoys.com/>
 - <http://cp.c-ij.com/english/3D-papercraft/index.html> – click on Download to view
 - a. Look at all the 3D object you can make at home, or you could come in and print one after school to make at home.
 - b. You might want to write these addresses in your Assignment Notebook.

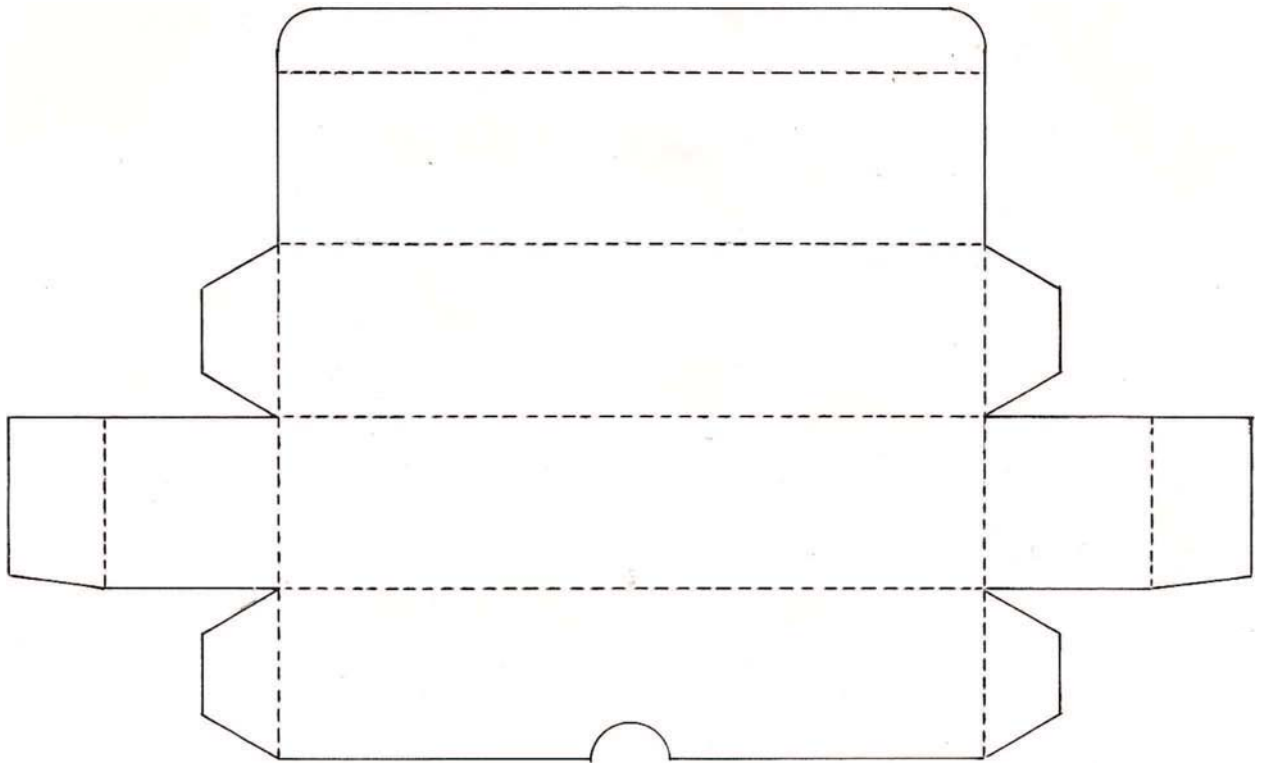

Cut out along dashed line

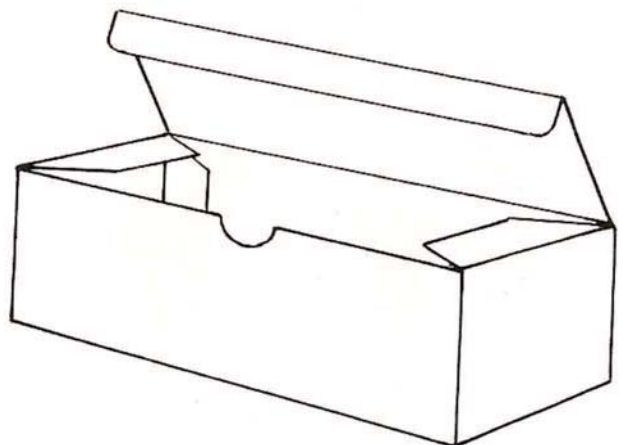

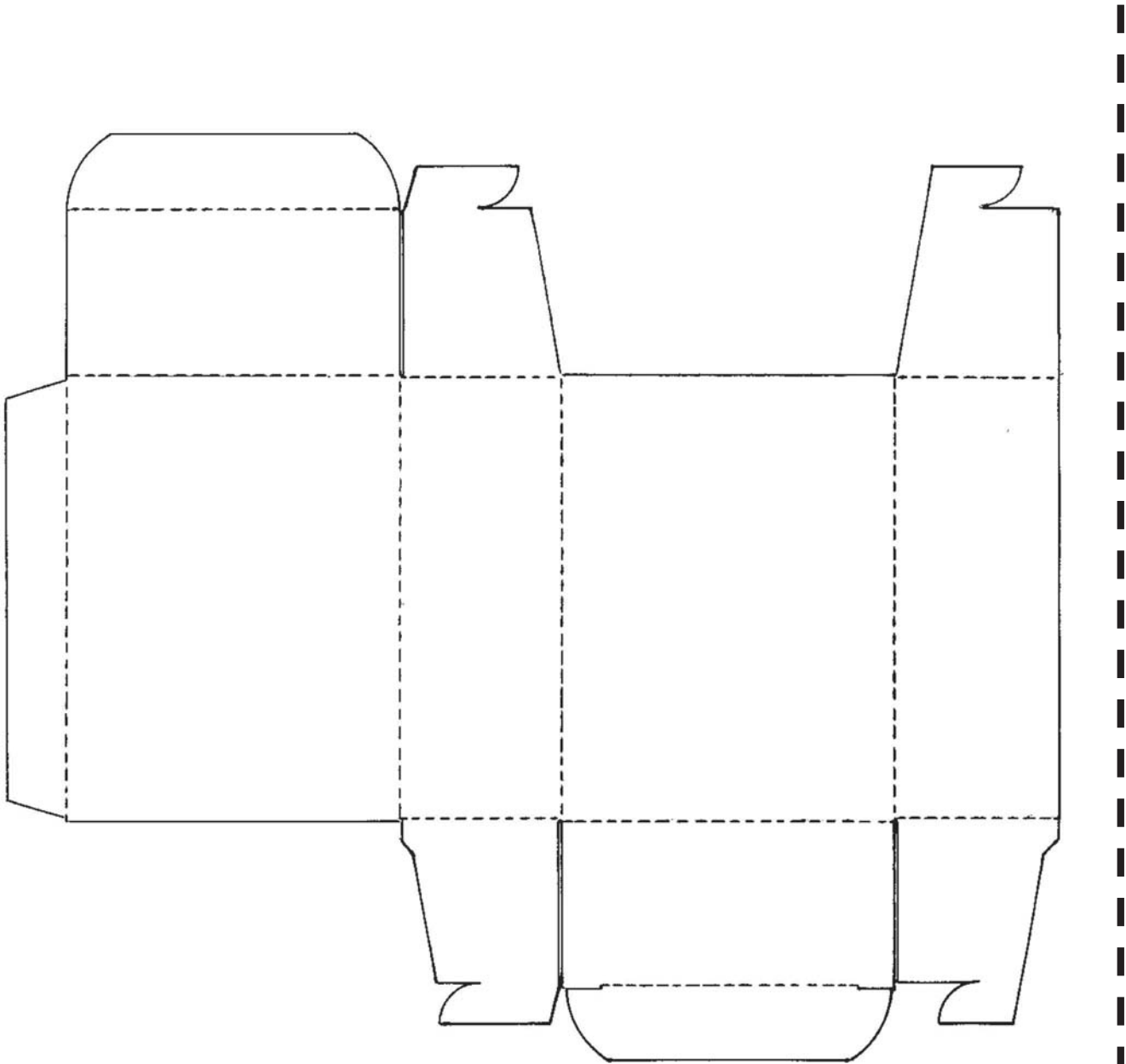

Cut out along dashed line

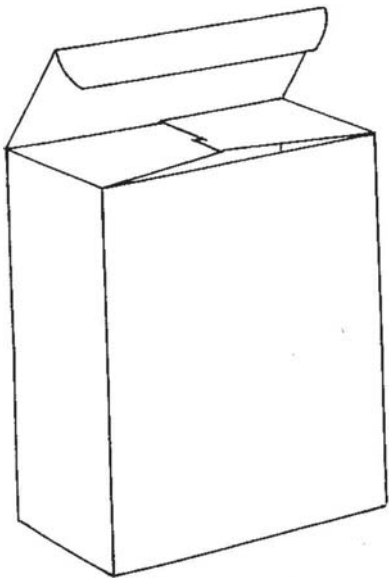

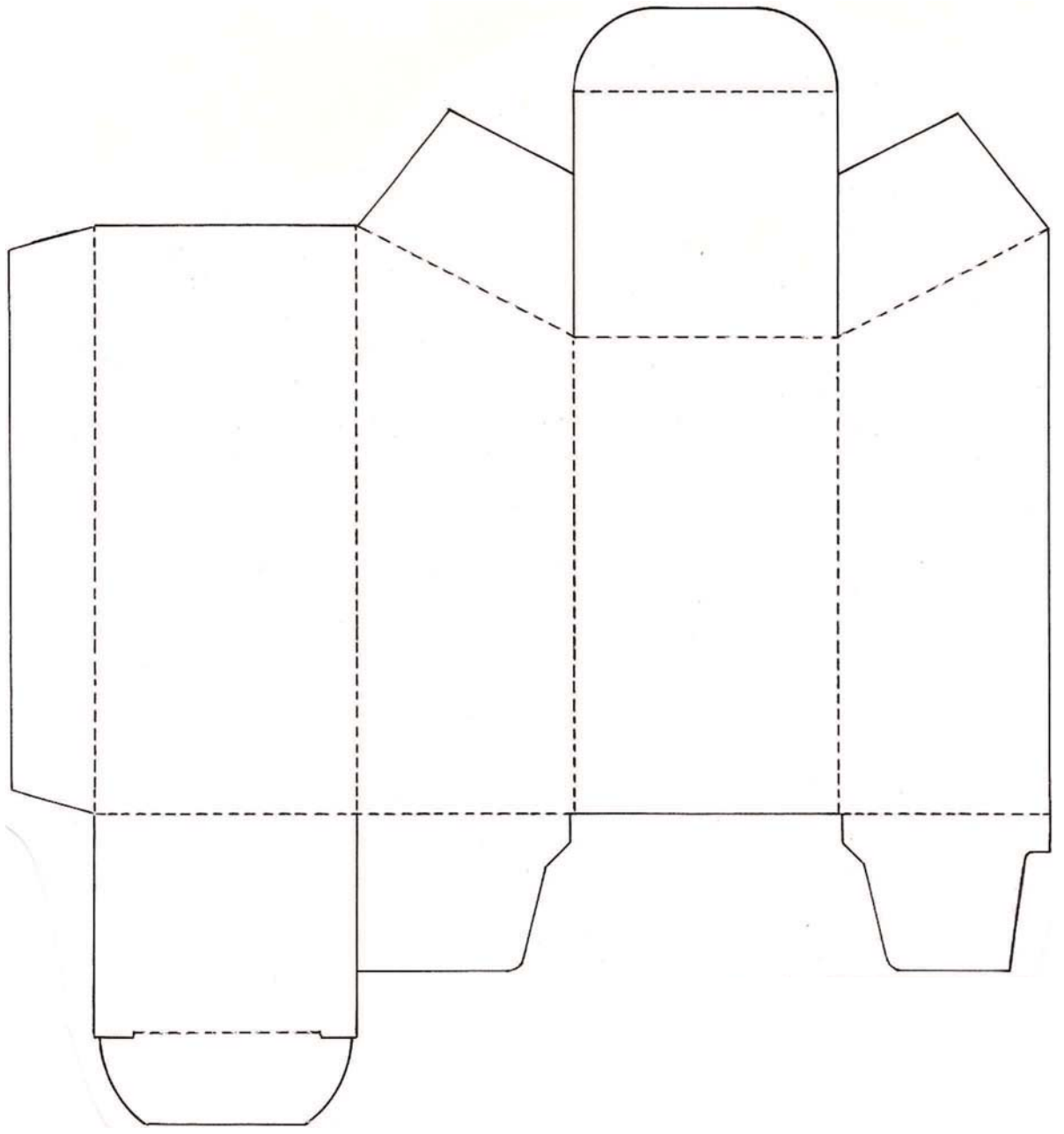

Cut out along dashed line

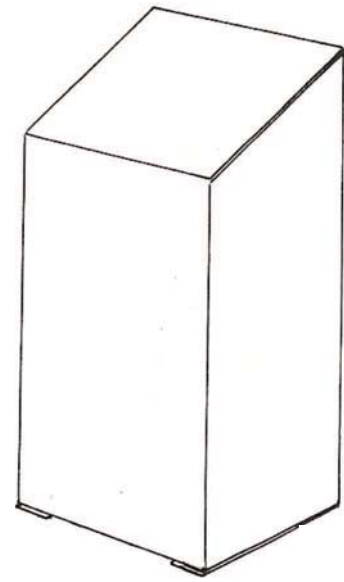

Design Process Putting Together the Pieces

Directions: Engineers use the Design Process to solve problems. You too can use this process to solve problems, situations and challenges. This activity will help you learn the steps of the process and know happens during each step.

Remove this page by cutting along the dashed lines. Cut out the “half” circles. Now, turn to Appendix D-2. With your partner, match the description on the “half” circles to the correct circle in the Design Process. When you feel you have matched the design process with the correct description, make double stick tape and tape it in place.

remove
along
this
line

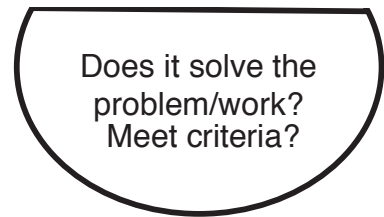
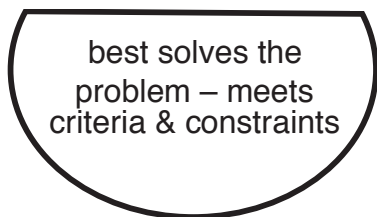
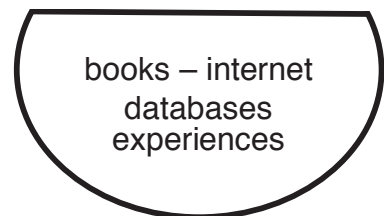
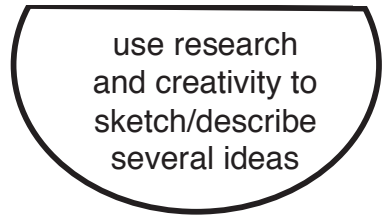
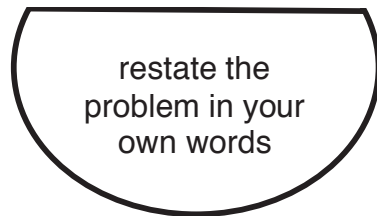
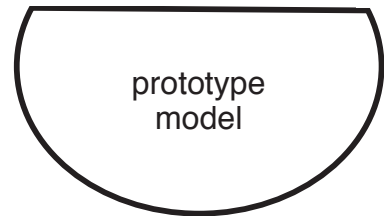

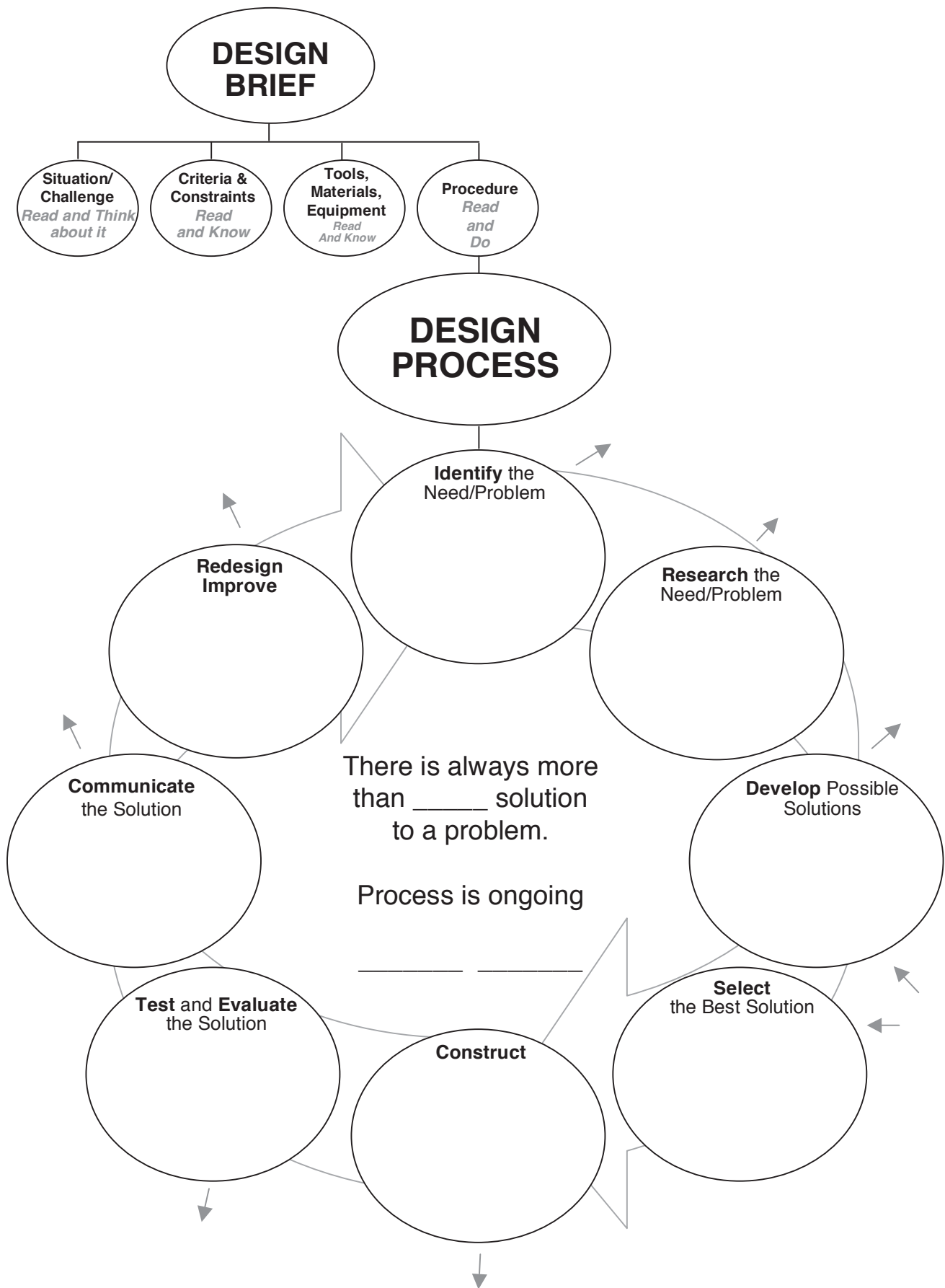

Engineering & Technology Notes

Why Study Engineering and Technology?

Technological Literacy

Technological Device
YOUR EXAMPLE

Tech Device:

Problem it solves:

Problem it creates:

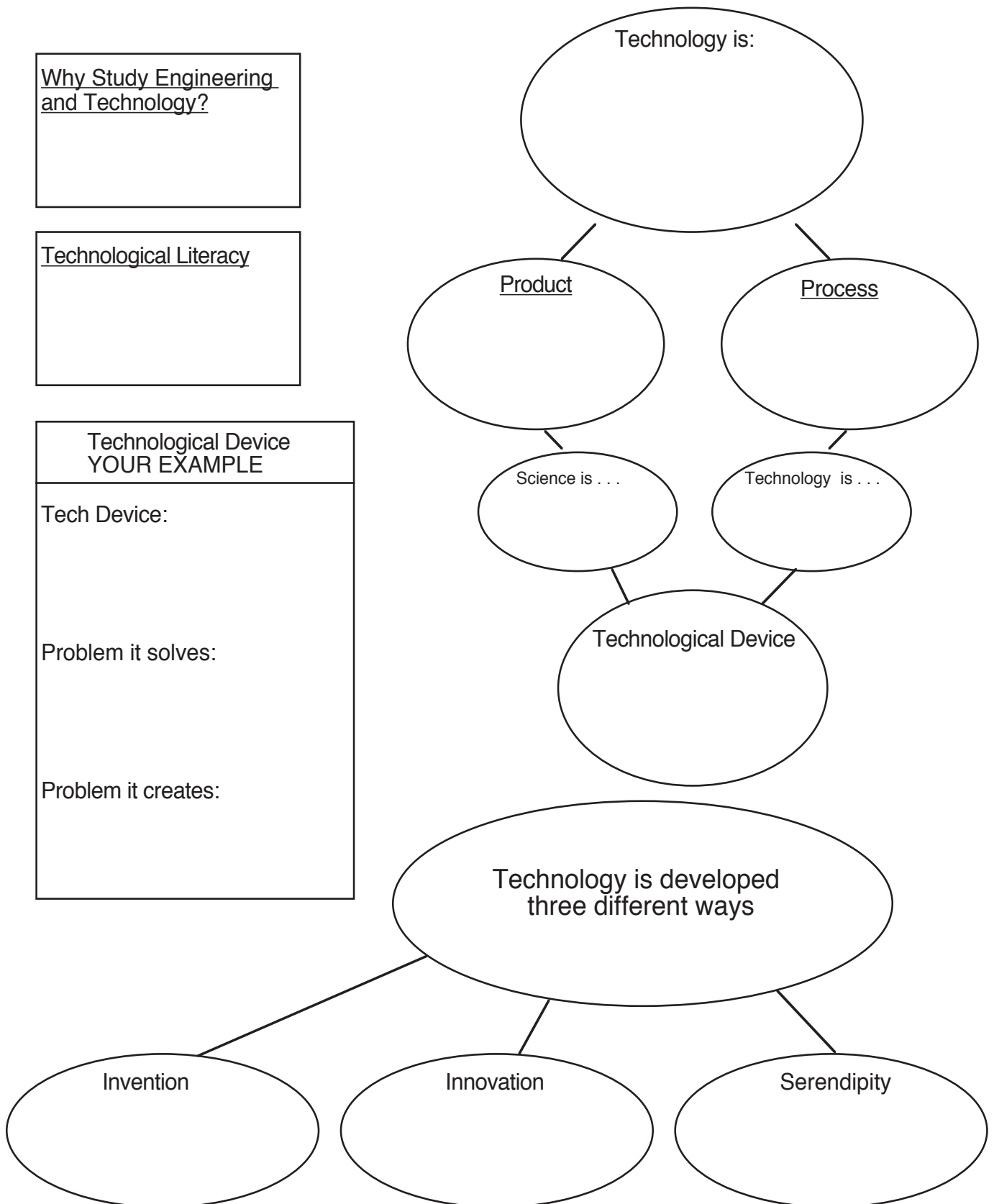

Engineering is . . .

Design is . . .

Design Process is . . .

Engineers use technology, science, design and the design process
to solve their
Situations/Challenges/Problems

Design Brief Product of Technology Poster

Name: _____ Eng. Ntbk. # _____ DUE: _____

Challenge/Situation

Inventions, Innovations, and Serendipities have satisfied our wants and needs. They have been developed throughout time effecting our past, the present and some cases our future. Your challenge is to create a poster about an existing product of technology using the criteria and constraints below. **EXAMPLES of posters can be found on the billboards in the lab.**

Criteria/Constraints

1. This poster will be done entirely out of class time. You may come to the lab after school, use the media center or you may do this at home.
2. Be on the **FRONT** of **one** 8.5" x 11" sheet of paper.
3. Organized - neat - shows effort. Looks like a poster not a report.
4. Have the **name** of the invention, innovation, or serendipity – see procedure below.
5. A **picture/graphic** of the invention, innovation, or serendipity.
6. State **why** it is an invention, innovation, or serendipity.
7. **Who** invented, innovated or discovered (serendipity) it.
8. **When** it was invented, innovated or discovered.
9. Based on your research, state an interesting **fact** about your invention, innovation, or serendipity.
10. **Cite** the resource(s) used for your research. Give the entire Internet address or book title, author, year published and page number.
11. This sheet attached lightly taped or stapled to back of poster:
12. Handed in by due date.

Tools/Materials/Equipment

Books, computer, printer, markers/crayons/pencils, paper, scissors, glue, tape – whatever you have around the house to be creative.

Procedure

1. **Identify** the problem by re-reading the situation/challenge.
2. **Research** the problem by finding possible products of technology that match the criteria/constraints – **you may not use any of the examples given in class or food.** HINT: if you cannot find all the criteria/constraints, pick another product.
3. **Develop** possible solutions by making a list of possible products found in your research.
4. **Select** the product that best fits the criteria and constraints.
5. **Construct** your poster by using the criteria/constraints as a checklist.
6. **Test** and evaluate your poster by looking at your criteria/constraint. Put a check by the number if you did that criteria/constraint.
7. **Communicate** the solution by handing in your poster **after** you do the next step.
8. **Redesign** or improve your poster by making any corrections to the poster to meet the criteria/constraints you do not have a check beside.

Assessment is based on following the criteria/constraints

Points earned

12 = A

11 = B

10 = C

9 = D

8 and below = not passing

Remember you can correct/do your work and hand it back in. FINAL DUE DATE: _____

Corrected on: _____ New Score Earned: _____

“A _____ is worth a thousand words.”

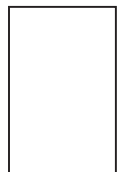
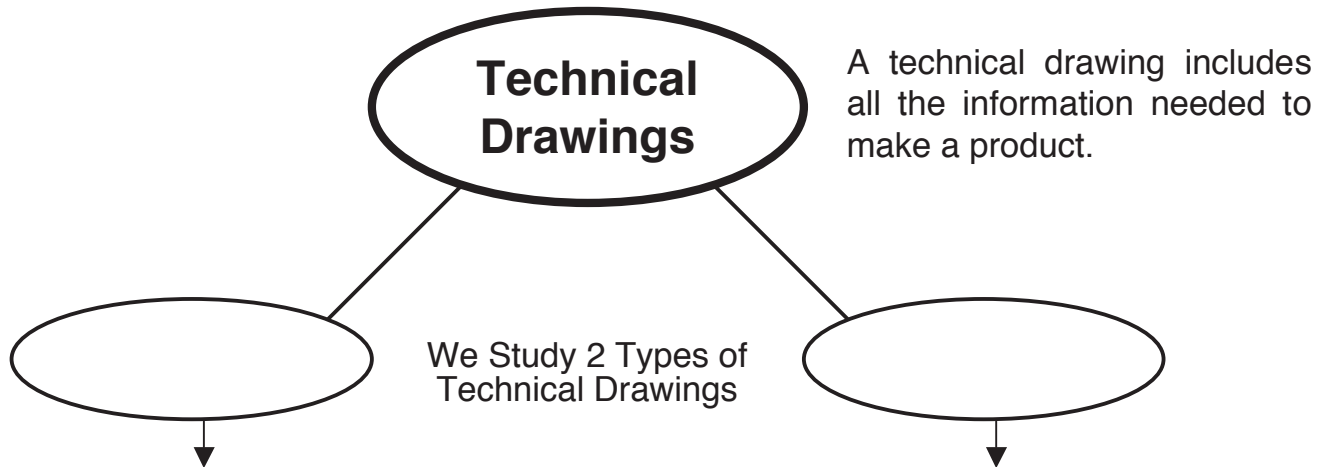

The 3 Views

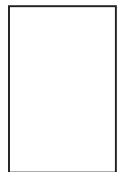
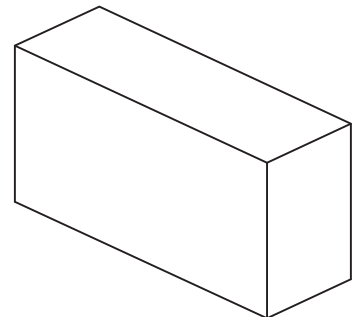

Length, Height, Width

X =
Y =
Z =

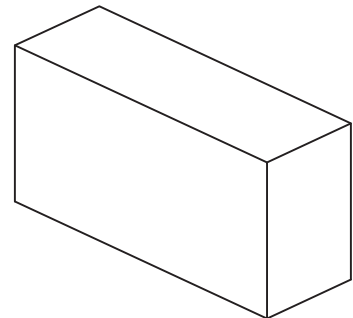

Alphabet of Lines

| | |
|--|----------------|
| | Object line |
| | Hidden line |
| | Center line |
| | Dimension line |

(Dimension = Measurement)

Scale: _____

Proportion: _____

Stock: _____

Object line: _____

Hidden line: _____

Center line: _____

Dimension: _____

Isometric Graph Paper

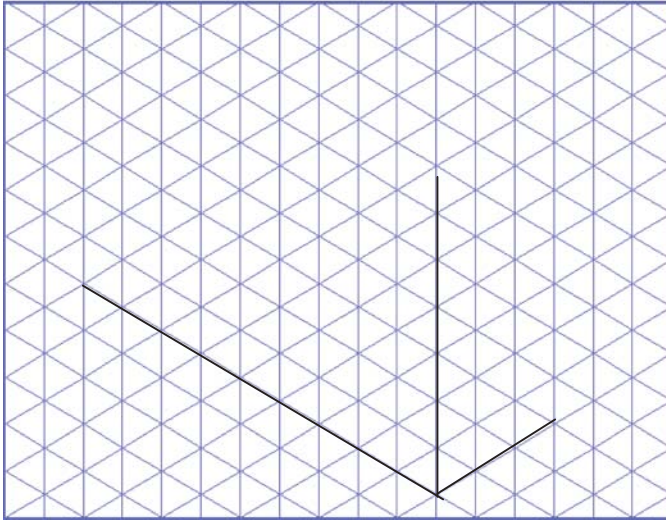

Steps to making an Isometric Drawing:

1. Study the drawing
2. Lightly Sketch X axis
3. Lightly Sketch Y axis
4. Lightly Sketch Z axis
5. Lightly Sketch basic geometric shape in front view
6. Lightly Sketch in top and side views
7. Lightly Sketch in details beginning with front view
8. Erase lines not needed
9. Darken object lines

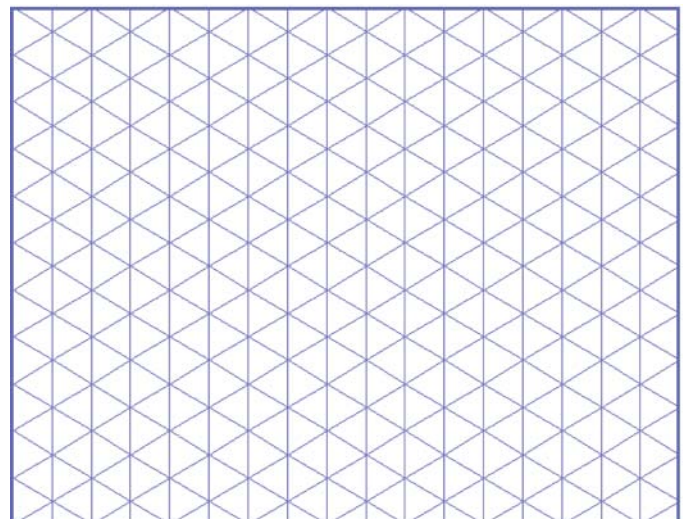
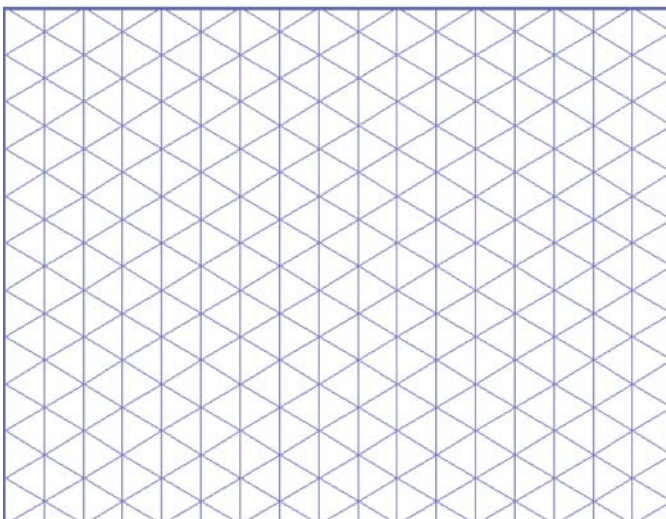
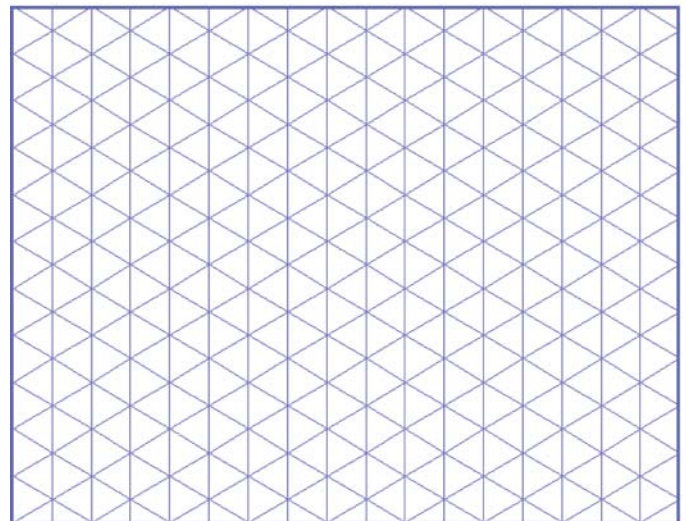
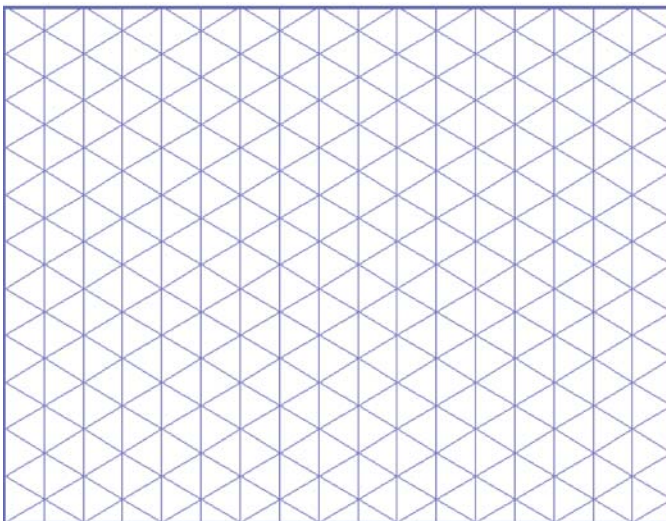

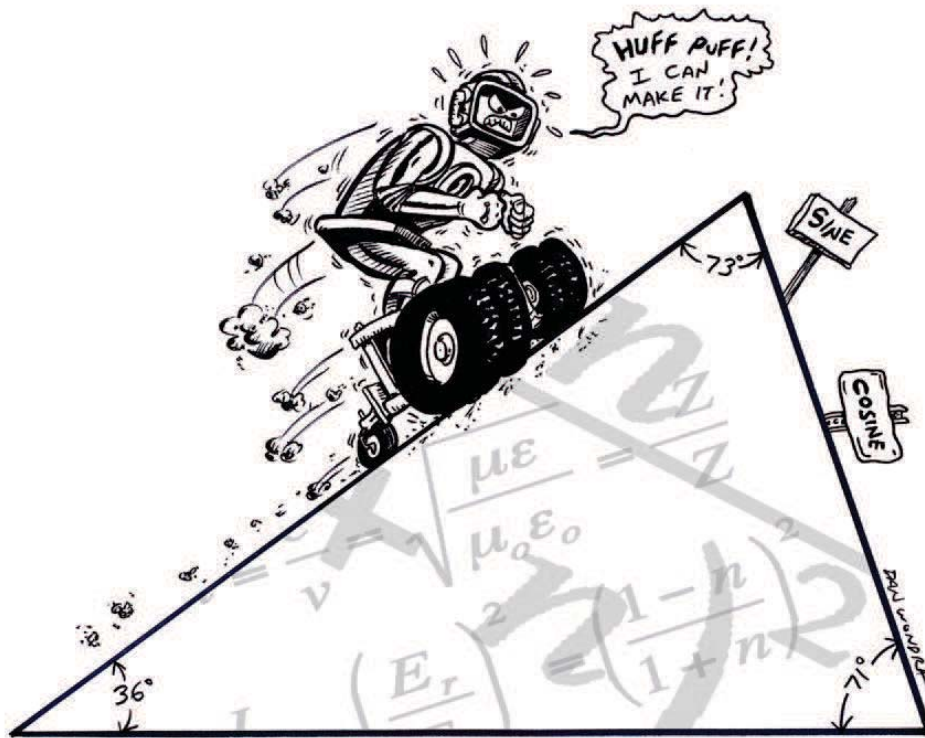

In Partnership With:



SSW 11: Robot General Lesson Ideas

As generated by SPIRIT teachers (October, 2008)

| Context | | | | |
|---------------|---------------|--------------|-----------------------|---|
| Moving TekBot | TekBot Const. | Eng Notebook | Concept | Lesson Idea |
| 1 | | | Angles | If you can change the angle of direction of the TekBot, what do you have to do to stay within an obstacle course? How about declination or inclination? (ramps) |
| 1 | | | Angles | How many degrees can the TekBot turn within a specific limited space? |
| 1 | | | Angles | How does the TekBot handle ramp angles? Calculate TekBot speed at different angles. |
| 1 | | | Area/Perimeter | Move TekBot in shapes and then solve for A or P, based on TekBot path measurements. |
| 1 | | | Area/Perimeter | Student moves robot to form shape with pre-given area or perimeter. |
| | 1 | | Astronomy | Compare TekBot to Mars Rover in its construction. |
| | | 1 | Astronomy | Research Mars and moon robots |
| | | 1 | Astronomy | Show how robots are used in space today. |
| 1 | | | Basic Facts | Move TekBot around flash cards and students answer the question. |
| 1 | | | Basic Facts | Put answers to math basic facts on floor. Partners drive TekBot to answer the problem. |
| 1 | 1 | | Batteries | How batteries function in a TekBot |
| 1 | 1 | | Batteries | Measure how long different types of batteries last. |
| 1 | | | Batteries | Use fully charged vs. not fully charged batteries to see effect on TekBot performance. |
| | 1 | | Bridge engineering | Understanding the design of bridges and have TekBot traverse bridge. |
| | 1 | | Bridge Engineering | Examine the weight limits of a bridge and test with a TekBot moving across the bridge. |
| 1 | 1 | 1 | Cell Biology | Can you make a comparison chart of cell structures to that of TekBot components? |
| 1 | | | Cell Biology | How do TekBot circuits compare with cell communication? |
| 1 | | 1 | Chemical Reaction | How long will the battery go before depletion? Rechargeable versus disposable can connect to slope. |
| 1 | | | Chemical Reaction | Observe batteries with different levels of charge and observe different reactions (movement of TekBot) How long does a battery type last? |
| | 1 | 1 | Chemical Reaction | What happens when a resistor is overloaded? Also, how do capacitors work? (the metals used, etc.). Documentation of results of tests. |
| | | | Circuit and Ohm's Law | How does the TekBot represent the equation $V=IxR$? Also, find I = instead of V, etc., solving for each variable. |
| | 1 | | Circuits | Use design process to solve problems related to circuits. |
| | 1 | | Circuits | Building a circuit out of popsicle sticks and tin foil which models a TekBot circuit. |
| | 1 | | Circuits | Drawing open/closed circuits as they might exist on the TekBots. |

| Context | | | | |
|---------------|---------------|--------------|--------------------------------------|---|
| Moving TekBot | TekBot Const. | Eng Notebook | Concept | Lesson Idea |
| 1 | | | Circumference | TekBots move around in circles and measure the circumference of those circles. |
| 1 | | | Circumference | Have the TekBot create several different type circles with students outlining the circle. |
| | 1 | | Circumference | Using a shoebox full of wheels, how do different sizes impact TekBot motion? |
| 1 | 1 | | Consumer decision: Honda vs. Hummer | Is a TekBot like a Honda or a Hummer? Compare mass, force needed, etc. to make a consumer decision. Futuristic applications. |
| 1 | | 1 | Coordinate Axis | Graphing movement as TekBot moves on a large grid. |
| 1 | | | $d = r \times t$ Algebra Equation | Can you explain how different equations represent TekBot motion? |
| 1 | 1 | 1 | Decimals | What is the force being applied by the TekBot? |
| 1 | 1 | | Decimals | Can you explain how the TekBot is moving using mathematics? Conversions, etc. |
| 1 | | | Decimals | How close can you measure TekBot movement? For example, to the nearest centimeter, etc. |
| | 1 | | Decimals | If I was an engineer for this TekBot how much would it cost to build it? |
| 1 | | | Definition of Life | Is the TekBot alive? Does it move, seek shelter, seek food, etc. |
| 1 | | | Definition of Life | What defines life? Is the TekBot living? Why or why not? |
| 1 | 1 | 1 | Design | If you were to design a robot that made you breakfast, what would it need to do? |
| | | 1 | Design Process | Illustrating it as you complete and create TekBot enhancements. |
| | | 1 | Design Process | Design your own TekBot with a different purpose. |
| | | 1 | Design Process | Figure out how to improve TekBot and make suggestions. |
| | | 1 | Dialectic Notebook | Can you explain your TekBot experiment? Your objectives? Your mistakes? Have handout made to have students use layout for labs. |
| 1 | | | Dinosaur | Velcro a dinosaur on the TekBot. Create a game to review dinosaur information. |
| | 1 | | Dinosaurs | Create mobile dinosaurs using the TekBot |
| | | 1 | Dinosaurs | Compare/contrast TekBots to computers (old and future), then to cars; things must evolve/become better! |
| 1 | | | Division | Apply $r \times t = d$ to find speed ($r = d/t$) when discussing motion. |
| 1 | | | Division | Use it to show differences in sizes and scale. |
| | 1 | 1 | Electricity | How does the TekBot use resistors? How about capacitors? |
| | 1 | 1 | Electricity | How does a particular circuit work on the TekBot? |
| | 1 | | Electricity | Your instructor has disabled your TekBot, how do you find what is wrong? |

| Context | | | | |
|---------------|---------------|--------------|---------------------------------------|--|
| Moving TekBot | TekBot Const. | Eng Notebook | Concept | Lesson Idea |
| | 1 | | Electricity | Can you create a simple circuit using tinfoil, popsicle sticks, LED, and battery? |
| | 1 | | Electricity/ Positive- Negative | What stops the flow of electricity? What happens when you hook things up wrong in a particular part of the TekBot? |
| 1 | 1 | 1 | Engineering as a Career | Can you create a KWL chart to discuss the topic of engineering? |
| | | 1 | Engineering Fields | What types of things need to have an engineer design them? |
| 1 | 1 | 1 | Engineering Problem Solving | Can you find a group solution to a particular TekBot situation/task? |
| | 1 | | Following Directions | Can you give multistep directions to follow in moving the TekBot? |
| 1 | | | Force | TekBot pushes things on different surfaces. |
| 1 | | | Force | Experiment with adding weight to the TekBot and observe performance. |
| 1 | | | Force | Show how different forces make it move differently, and use vectors to illustrate the forces. |
| 1 | 1 | | Formulas | Can you explain TekBot speed mathematically (velocity)? Can you explain its acceleration? |
| 1 | | | Formulas | Can you move the TekBot to show $D = R \times T$? How about $S = D/T$? |
| | 1 | 1 | Formulas | Can you measuring friction using different surfaces? |
| 1 | | | Fractions | Changing fractions to percentage in how far a TekBot is moving on a path. |
| | | 1 | Fractions | Converting % to fractions and look at the percent grade of a ramp. |
| 1 | 1 | 1 | Friction | Can you illustrate Newton's Laws with a TekBot? |
| 1 | | 1 | Friction | Can you calculate rate of ascent for varying inclines? |
| 1 | | | Friction | Can you use different weights and surfaces to test friction? |
| | | | Function of robots in society | What qualifies something as a robot? Can they be made more "human"? |
| 1 | | | Geometric Shapes | Can you create different geometric shapes by attaching yarn to the TekBot and moving it around a grid? |
| 1 | 1 | 1 | Graphing | Can you represent TekBot movement on a coordinate axis? |
| 1 | 1 | 1 | Graphing | Can you represent the various components of the TekBot using a Venn Diagram? |
| 1 | | | Graphing | Can you show the results of TekBot speed/change variables on a graph? |
| 1 | | | Graphing | Can you locate the positions of the TekBot based on ordered pairs? |
| 1 | | | Graphing | Can you set up a race track and graph distance vs. time of the TekBot? |

| Context | | | | |
|---------------|---------------|--------------|---------------------------|---|
| Moving TekBot | TekBot Const. | Eng Notebook | Concept | Lesson Idea |
| 1 | | | Graphing | Is it possible to move the TekBot in a truly straight line? (add seconds for segments off the line). Graph segments or average time to travel course. |
| 1 | | | Graphing | Can you plot the diagonal distance of the TekBot using a grid and the distance formula? If the robot picks the points of its own path? |
| | 1 | | Historical Research | See how robots have changed, compare/contrast robots of the past, present and future. |
| | | 1 | Historical Research | Timeline of the invention of silicon chips. |
| | | 1 | Historical Research | Research the development of motor technology. |
| | 1 | | iMovie | How to construct the TekBot using step by step directions. |
| | 1 | | iMovie | Create a tutorial where students show how electronics tools should be used safely. |
| | | 1 | Innovation vs.. Invention | Are their real world applications of our TekBot? |
| 1 | 1 | 1 | Inquiry | What if the TekBot could be "super sized"? How could it move better? (e.g. larger wheels, larger batteries.) |
| 1 | 1 | | Inquiry | How can robots work to help in today's industry? |
| | 1 | | Inquiry | Why do you need a resistor? Allow students to demonstrate the answer. |
| | | 1 | Inquiry | What questions would a person new to robotics have about your TekBot? Give them a TekBot and have them record questions, etc. |
| 1 | | | Integers | Movement on a big number line to use the TekBot to show integers. |
| 1 | | | Integers | Use with coordinate graphs to show negative and positive numbers. |
| | 1 | | Inventions | How would you change a TekBot. What purpose would it have to help mankind? |
| | | 1 | Inventions | Design new attachments for the TekBot. |
| 1 | 1 | 1 | Lab Safety | In what ways could you inadvertently damage the TekBot. How might it damage you inadvertently? |
| | | 1 | Lab Safety | Why do we need lab safety when working with the TekBot? Examples? |
| 1 | | | Lesson Set | How can a TekBot be used to explain integers to a younger student? |
| 1 | 1 | 1 | Life | Is the TekBot alive? Why, why not. |
| | 1 | | Magnetism | Explain how a motor works with a TekBot. |
| | 1 | | Magnets | Study how magnets work inside a motor with a TekBot. |
| 1 | | | Mass | How much mass can the TekBot transport? |
| 1 | | | Math Facts | Move TekBot on a number line to do basic facts. |
| 1 | | | Mean, Median, Mode | How do different TekBots materials impact its performance? |
| 1 | | | Mean, Median, Mode | What is the average time a TekBot can traverse a maze? Calculate measures of central tendency. |

| Context | | | | |
|---------------|---------------|--------------|----------------------------------|--|
| Moving TekBot | TekBot Const. | Eng Notebook | Concept | Lesson Idea |
| 1 | | 1 | Mean, Medium, Mode | Calculate and graph central tendency of races, obstacle courses, etc. Record construction times. |
| 1 | | | Mean, Medium, Mode | Navigate maze--determine class mean, median |
| 1 | | 1 | Measurement and Unit conversions | Is mph appropriate unit of measure? What's a better unit? Create chart of different units. (convert weight unites) |
| 1 | 1 | 1 | Metric Measurement | Distance measurement size of TekBot, parts sizes documentation of sizes |
| 1 | | | Metric Measurement | Have TekBot navigate maze measuring metric, and mass-grams. |
| 1 | | | Metric measurement | Measure mass of different parts of the TekBot. Measuring distance traveled on track. |
| | 1 | | Metric Measurement | Unit conversions while building |
| 1 | | | Metric System | Converting and measuring in metric a TekBot moves across the floor. |
| 1 | | | Metric System | Measuring distance and compare metric to standard measurements. |
| 1 | | | Metric System | Measure distance around room as TekBot travels. |
| | 1 | | Metric System | Measuring weighted components of the TekBot. |
| 1 | | | Microbiology | Using a moving TekBot to simulate the spread of viruses or bacteria. |
| | | 1 | Microbiology | Compare and contrast a TekBot with a cell, could lead to other cells. |
| 1 | | 1 | Mode, Median, Mean | Using TekBot to make trial runs of distance and time and record the results. Discuss mean, median, mode. |
| | 1 | | Motors-How They Work | How do motors work, parts, functions. |
| 1 | | | Newton's Law of Motion | Have different weighted objects in front of TekBot to illustrate Laws of Motion. |
| 1 | | | Newton's Law of Motion | Find Newton's 2nd law of Motion by placing different masses on the TekBots and measuring speed. |
| 1 | | 1 | Newton's Laws | |
| 1 | | 1 | Newton's Laws | $F=ma$ Add weight to the TekBot to find change in velocity and acceleration. |
| 1 | | 1 | Newton's Laws | Moving-gravity; Notebook-definitions processes of Newton's Laws |
| 1 | | | Newton's Laws | What happens when we change the direction of a wheel- -what happens when an object disturbs the laws of motion. |
| 1 | | | Newton's Laws | Explore $F=ma$ Add mass to TekBot and measure speed and acceleration. |
| 1 | | 1 | Newton's Laws (Part A) | Definitions and formulas along with drawings in the notebook. Simulation tests. |
| 1 | | | Newton's Laws (Part B) | use the actual TekBot to experiment and incorporate these formulas. Record findings in notebook. |

| Context | | | | |
|---------------|---------------|--------------|---------------------------|--|
| Moving TekBot | TekBot Const. | Eng Notebook | Concept | Lesson Idea |
| 1 | | | Newton's Laws of Motion | Inertia (First Law) use and object with and without a seatbelt. $F=MA$ (2nd Law)--play with the mass to see the effect. (3rd Law) Action/Reaction--more vs. less mass--run TekBot into things. |
| 1 | | | Newton's Laws of Motion | Looking at how there must be an energy source to run something, including TekBots. |
| 1 | | | Note taking Documentation | Learning how important note taking is. Teaching combination note taking. |
| 1 | 1 | 1 | Operations | If you have x dollars and you need to get y number of parts to fix your TekBot, how and what could you purchase to complete your task? |
| | | 1 | Outline Notes | Document procedure in outline form. |
| | 1 | | Parts of a Circle | Calculate ratios of different types of wheels. Different calculations of diameter, radius, pi |
| 1 | 1 | 1 | Percent | Efficiency, drag. Hypothesis-engineering changes create percent of change in performance |
| 1 | 1 | | Percent | Track percentage completion. Mass percentages of components. |
| 1 | | | Percent | Analyze percent difference, percent change. |
| 1 | | | Percent | Use for a completion of a maze (% finished). |
| 1 | | | Percentage | Find the percentage of total distance traveled. Find the percentage of ramps used with slope. |
| 1 | | 1 | Podcasting Technology | Give oral directions for another to follow around an obstacle course. |
| 1 | | | Polygon | Move in the shape of a polygon and see if TekBot turn radius is sufficient. |
| 1 | | | Polygons | Creating shapes with the TekBot movement and recording with marker. |
| | | 1 | Polynomials | Solving formulas of the TekBot as it moves in parabolic paths. |
| | | 1 | Polynomials | Use with algebra and find resistance and describe paths of the TekBot. |
| 1 | 1 | | Positive-Negative | Moving TekBot simulating number line. Positive, negative--electricity lesson |
| 1 | | | Positive-Negative | "Mobile counter" -- number line along baseboard with TekBot |
| | 1 | 1 | Positive-Negative | Conduction-Positive/Negative junctions, resistors, Forward Advancement--reverse for +/- number calculations. Documentation of connections |
| | 1 | | Positive-Negative | Show what happens if you change the battery, balancing of protons/neutrons |
| | | 1 | Positive-Negative | Use the diode to show the positive flow. |
| 1 | 1 | 1 | Problem Solving | "Your job is to get the TekBot to do this...." Generate a list of inquiry--"I wonder what would happen if..." |
| 1 | 1 | 1 | Problem Solving | How can you document and why. Quality control., trouble shooting. What mathematical knowledge required to build/operate TekBot? |
| | 1 | 1 | Problem Solving | Using the dialectic method for engineering log book |

| Context | | | | |
|---------------|---------------|--------------|--|--|
| Moving TekBot | TekBot Const. | Eng Notebook | Concept | Lesson Idea |
| | | 1 | Problem Solving | How do I solve this? What could this be used for? What's the best solution? |
| | | 1 | Problem Solving | What do you do if it doesn't work. Brainstorm ways to test TekBot. |
| 1 | | | Rational & Real Numbers | Divide the circumference of circular paths by diameter for students to discover the value of Pi. |
| 1 | | | Ratios, torque, Problem Solving, Inquiry | Alter gear ratios and show/test relationships. |
| | | 1 | Real Numbers | Experiment with different formulas and illustrate the Real number system. |
| | 1 | | Recognizing Electronic Components | Lesson on resistor colors and their values. |
| 1 | 1 | 1 | Reflection | What math skills are required to build your TekBot? Can you identify all that you used? |
| 1 | 1 | | Scale | Compare original wheels to larger/smaller wheels |
| 1 | | | Scale | Problem solving-changing |
| | 1 | | Scale | How to scale the parts to fit the construction. |
| | | 1 | Scale | Compare a TekBot to a real car and include a scale diagram. How does a tire to body scale change between a real car to a TekBot. |
| | | 1 | Scale | Have students estimate size conversions relative to different payloads. |
| 1 | 1 | 1 | Science Ethics | What are the ethics of creating. So does the ethics of applications |
| 1 | 1 | 1 | Scientific Method | Examine how a trailer impacts TekBot performance. |
| | 1 | | Scientific Method | Order of operations for construction. Trial and errors. |
| | | 1 | Scientific Method | Compare scientific method to engineering method. |
| | | 1 | Scientific Method | Give a problem and think of ways we could use the TekBot to help solve that problem. |
| 1 | 1 | 1 | Simple Machines | What simple machine is used to move the robot, building the robot. Create a Venn diagram of how they are common/different. |
| | 1 | | Simple Machines | How do simple machines work? |
| | | 1 | Simple Machines | What are the simple machines? How are these making the TekBot move more easily? |
| | | 1 | Simple Machines | How things work. |
| 1 | 1 | 1 | Slope | Capacitors/resistors, linear slope vs. exponential slope |
| 1 | | | Slope | Set up a ramp at different algebraic slopes and observe TekBot movement up the ramp |
| 1 | | | Slope | Figure out the slope of the a ramp and its impact on TekBot |

| Context | | | | |
|---------------|---------------|--------------|------------------------|---|
| Moving TekBot | TekBot Const. | Eng Notebook | Concept | Lesson Idea |
| 1 | | | Slope of a line | Using ramp--how slope affects movement of car. (incorporate friction) |
| 1 | | | Sound | Adjust the pitch and volume with differing resistors, etc. |
| 1 | | | Sound | Drive across different materials and compare the sounds they make. |
| 1 | | | Sound | Measuring sound waves, comparing to electrical waves, using the context of the TekBot. |
| 1 | | 1 | Sound (Doppler Effect) | Attach a noise maker to TekBot and have students cover their eyes. Students can describe the path of the TekBot as the operator moves it around the room. |
| 1 | | | Speed | Graphing different speeds dragging different weights with TekBots (charts/spreadsheet applicable also) |
| | | 1 | STEM Careers | S.T.E.M. career research criteria, including salary, education, and daily work load. |
| 1 | 1 | | Systems of Equations | Measuring friction |
| 1 | | | Systems of Equations | Use the TekBot to visually demonstrate "solution," to a system by physically showing intersections. |
| | 1 | 1 | Technical Drawing | Drawing a diagram of the TekBot construction process. |
| | | 1 | Technical Drawing | Design TekBot accessories using technical drawing. |
| | | 1 | Technical Drawing | Use to CAD-measure components and make a scale drawing. |
| | | 1 | Technical Drawing | Learning to draw TekBot circuits and how it completes a circuit. |
| 1 | 1 | 1 | Technology & Society | Brainstorm the ways robots are being used in society. |
| 1 | | | Technology & Society | 1. Mars rover 2. Bomb Squad 3. Vacuum cleaner and pool cleaner. |
| | | 1 | Technology & Society | Have a discussion on how to improve the TekBot to also discuss about engineers. |
| | 1 | 1 | Technology in Society | Have an engineer come and explain the parts of a TekBot. |
| | | 1 | Technology in society | Discussion about how technology is used in society. |
| | | 1 | Technology System | Where Robots fit in a system. Mind mapping. Kids Spiration & Inspiration Software |
| 1 | | | Terrains | Varied terrains and observing how the TekBot responds |
| 1 | | | Time | measure time from point A to Point B as TekBot travels. |
| 1 | | | Time | Estimate time for distance traveled with a TekBot. |
| 1 | | | Time | Drive TekBot around polygons outlined on floor and measure times and compare for shapes. |
| 1 | | | Time | Races--measure the amount of time to travel a race path. |

| Context | | | | |
|---------------|---------------|--------------|------------------------------------|---|
| Moving TekBot | TekBot Const. | Eng Notebook | Concept | Lesson Idea |
| | 1 | 1 | Transistor | Demonstrate what it is' give examples outside of TekBot constraints. |
| | 1 | | Transistor | How does a transistor affect your machine? |
| | 1 | | Use of electronic components | Using VOM to test components and understand usage for them. |
| 1 | 1 | 1 | Using Formulas | Solving any physics equation after finding path with the TekBot. |
| | | 1 | Variables | Solve problems involving circumference, power, velocity, etc. |
| 1 | | | Velocity | run the TekBot and measure number of revolutions per time and how far it goes per time. |
| | | 1 | Velocity | Velocity of TekBot, math terms in notebook. |
| 1 | | | Velocity, Algebra, Problem Solving | In 60 seconds what is the largest square you can make? |
| 1 | | | Velocity, Distance | Mapping a room. |
| 1 | | | Video Technology | Create a video through the viewpoint of the TekBot. Use garage band, etc. to create feelings, etc. in the film. |
| 1 | 1 | 1 | Voltage | Use of multimeters |
| | 1 | | Voltage | Test resistors $V=IxR$ Experiment with multimeter. |
| | 1 | | Voltage | measuring voltage using batteries--increase voltage |
| | 1 | | Voltage | How does the TekBot change using different size batteries |
| 1 | | | Weather | Examine road conditions and performance of the TekBots on different roads. |
| 1 | | | Weather | How does weather affect the TekBot? |
| | 1 | | Weather | Compare TekBot performance at different temperatures. |

To Inspire Tech Kids, Inspire Tech Teachers

Teachers build robots in Nebraska, fix marine problems in California

The Silicon Kids:
Fourth In A Five-Part Series

BY JULIE VALLONE
FOR INVESTOR'S BUSINESS DAILY

Listen up class; here's your lesson for the day: If you want inspire the next generation of tech professionals, start with their middle school science and math teachers.

Studies show declining interest among college students in computer science, engineering and related fields. Many fear the U.S. will face a shortage of skilled tech workers.

Thus, a growing number of university educators and business executives say it's crucial to start early by getting kids interested in tech before they reach high school.

Math and science teachers want to do just that, but they often lack the out-of-classroom experience needed to show their students how their math homework or science experiments actually relate to rewarding careers in technology.

People such as Bing Chen, head of the Computer & Electronics Engineering Department at the University of Nebraska, are trying to change that. After visiting area high schools, he found that not enough was being done to expose students to his field.

"When I would meet high school students interested in engineering, there weren't very many of them, and they weren't particularly well prepared," he said. "It struck me that we needed to give younger students some introduction to engineering principles and a look at engineering as a possible career path before they reach high school."

So Chen and his colleagues created the Silicon Prairie Initiative on Robotics in IT, or Spirit, program for teachers and students. This past summer, the university invited 32 middle school teachers from Omaha, Neb., schools to participate in a two-week, hands-on engineering workshop.

Its agenda was drawn from the school's undergraduate engineering curriculum. Teachers learned engineering principles by building a small robot from scratch — using math, science and information technology, or IT.

"Frankly, our math and science teachers are not given many opportunities to explore engineering," Chen said. "Our workshop was designed to give them exposure and build skill sets in this area."

First Session Was Experiment

The Spirit program also includes summer workshops and school activities for kids, as another means of drawing young people to the field.

Chen says the program, in its first year, received a positive response from the teachers.

"This summer's program was experimental; we really didn't know what to expect," he said. "We found we had quite a diverse mix of teachers attending our workshop, with ages ranging from grandparents to very young teachers just starting out. They were all excited when they left."

Now that the teachers are back in the classroom, Chen says, they're able to incorporate what they learned into their lesson plans, and they're better able to identify which young people have the potential to be engineers.

For the National Middle School Aerospace Scholars, or Namas, program administered by San Jacinto College in Pasadena, Texas, robot building is also on the agenda.

The school, which enjoys a close relationship with the NASA-Johnson Space Center in nearby Houston, invites 150 teachers from eight states to attend year-round workshops where they learn about the aerospace industry.

"We need to attract young people to the aeronautics field, and believe

we can hook them using the excitement of space and robotics," said math professor Sharon Sledge, one of the program coordinators. "We can also help the teachers get more students involved in math and science by building what they've learned into their curriculums."

As part of the workshop, teachers tour NASA, experience flight simulations used by the astronauts, learn about what it takes to launch a spaceship and talk to astronauts and others who work at NASA.

"We want to send the message that it takes more than astronauts to have a space program," Sledge said. "The teachers meet people from a variety of fields, so they understand that you can be a marketing or accounting major and still work for NASA. They learn that many NASA employees are everyday people."

Includes Videoconferencing

The program also helps teachers incorporate what they're learning into their curriculum, and lets them communicate with their students back in their classrooms through videoconferencing, Sledge says.

Farther west, on California's Central Coast, science and math teachers are getting a taste of in-the-field scientific inquiry through the Marine Biotechnology & Bioinformatics program at Moss Landing Ma-

rine Laboratories, part of California State University, Monterey Bay. At workshops during the summer and throughout the year, teachers learn how to investigate marine problems by gathering field samples, working in a professional marine lab environment, and using biotech gear to manage and analyze data.

Teachers are also given help in integrating their experiences into their curriculums. Like all the programs here, the program receives funding from the National Science Foundation, among other sources.

"We talked to teachers when we were designing the program, and they said they wanted help bringing interesting experiences to students in the classroom," said Simona Bartl, program coordinator and adjunct professor at CSU. "Only a few had experience doing actual research and being in the lab with scientists. Most had gone through science (teacher) education programs, where they're just not exposed to these aspects of the field."

The marine research workshops are designed to give teachers experience they can take back to the classroom, share with their students and inspire them to consider careers in marine science.

"Some of the best teachers we've encountered once worked in the science field and later went into teaching," Bartl said. "They have a lot of creative ideas about how to make science come to life in that classroom. With our program, we hope to give the other teachers, and the general public, a better understanding of what science is and what scientists do. We also want to show them how science is linked to the environment, public policy and other aspects of our lives."

Coming Friday: Some New York middle and high school students are learning how to use state-of-the-art forensic technology and research to investigate mock crime scenes. The curriculum looks less like a science class and more like an episode of the popular CBS crime show, "CSI."



School teachers build robots at a U. of Nebraska-Lincoln tech workshop.

SPOTLIGHT

faculty

Reaching the Millennium Generation

Bing Chen believes the best way to get students interested in engineering is to ignite their creative urges.

That's why the Department of Computer Electronics and Engineering has used the TekBot® as the glue between courses since 2004, said Chen, the department's chairperson. Now he is introducing the TekBot® to potential students as well.

The TekBot® is a 9-inch by 5-inch robot. Each student in the department receives a TekBot® at the beginning of his or her freshman year. Students use concepts from their engineering courses—and their imaginations—to customize a basic robot each semester through their senior year.

Need more power? Install a new motor. Want to control the robot while watching television? Build an infrared remote control. A group of juniors even programmed their robots to play laser tag.

"The TekBot® is a fun learning platform," junior Dan Norman said. "Once you put a microprocessor on there, you can put on all sorts of other applications."

Chen said the TekBot® was one way to keep students excited about engineering and apply their coursework to a tangible product. The curriculum was developed at Oregon State University.

After observing how popular the TekBot® was among college students, Chen realized that robotics could be an effective tool to get younger students interested in engineering. He recently received a \$1.17 million grant from the National Science Foundation to bring TekBots® to middle school classrooms, particularly in low-income areas. Each TekBot® costs \$100.

The pilot project will begin this fall in the Omaha Public Schools.

"Part of the problem in getting students interested in engineering is that K-12 education includes math and science curriculum but not engineering," Chen said. "What are fundamental engineering principles? Why should teachers encourage their students to consider engineering as a profession?"

He wants teenagers to understand that engineers developed many of the electronic gadgets they use daily, such as MP3 players,

cellular phones and plasma screen televisions.

"We want them to understand that engineering applies knowledge to benefit society," Chen said.

The teachers participating in the TekBot® pilot program are critical to the program's success, he said. In July, the department hosted a two-week workshop to train 30 Nebraska middle school teachers to build a TekBot® and develop lesson plans, many of

which reinforce basic math and science skills. After the workshop, participants will meet monthly to share their progress and get new lesson ideas.

Jennie Premer, who teaches seventh grade

TekBot® continued on page 6



■ David Shabram, a teacher at Westside Middle School, cuts a wire that he soldered onto the motor terminals of his TekBot®. Inset: Bing Chen

TekBot® continued from page 5

at McMillan Magnet Center, said she would use the TekBot® to reinforce mathematical standards.

“It gives students an immediate visual on how, for instance, slope works,” Premer said.

Chen said the workshop was an intense course in circuitry, soldering and the societal impact of robots. For many teachers, the workshop was the first time they’d experimented with welding and circuitry.

“These teachers represent the front line of math and science education,” Chen said. “We have to empower our teachers and give them a sense of possibility about engineering sciences.”

The college is working with faculty from the University of Nebraska at Omaha’s College of Education to measure the program’s effectiveness. Chen said he hopes someday, there will be enough schools using the curriculum to have a citywide TekBot® competition.

“We have to make certain that our youngest children have a sense that engineering is a good opportunity,” he said. “We have to reignite the sense of wonder, the sense of creativity, of why this is a dynamic, not static, subject.”

—*Ashley Washburn*

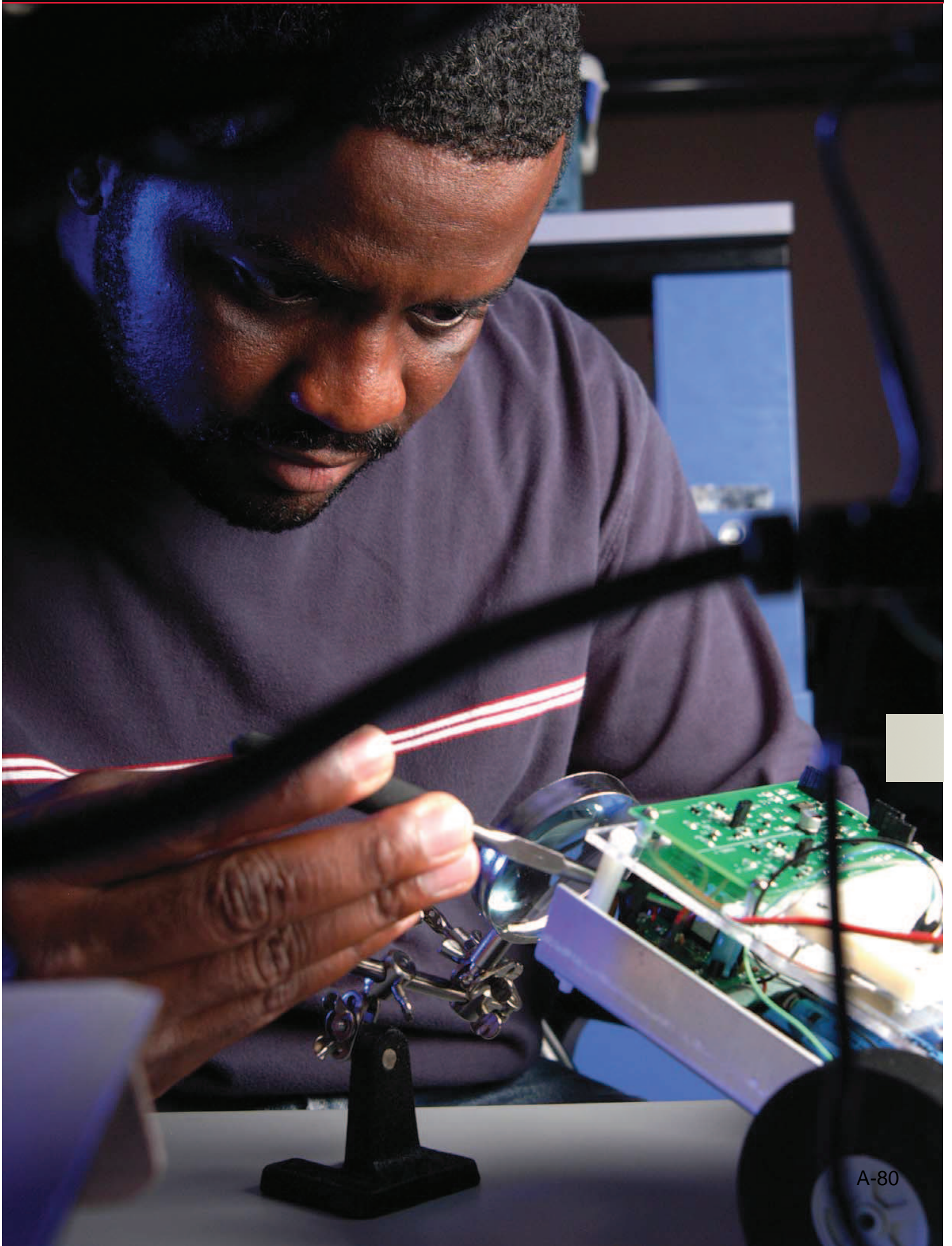

■ Call it “Invasion of the TekBots.” At the Peter Kiewit Institute, these little robots – raw circuitry and wires on wheels – are rolling into classrooms, morphing into high-tech gadgets with wireless communication and video systems as innovative students tinker with them.

Bing Chen, chair of UNL’s Computer and Electronics Engineering Department at the Omaha-based institute, couldn’t be happier with these 21st-century teaching tools. He introduced TekBots to the university’s engineering programs two years ago to encourage students to think creatively about applying classroom knowledge and to have fun with engineering. Now, he’s letting TekBots loose in Omaha’s middle schools with his new Silicon Prairie Initiative on Robotics in Information Technology, or SPIRIT, program.

Funded by a \$1.2 million four-year grant from the National Science Foundation and in collaboration with Omaha Public Schools, SPIRIT is teaching middle school teachers to use TekBots to illustrate algebraic equations and to demonstrate such principles as friction, wireless and computer processing, and electronics. For example, students can learn the circumference of a circle equals $2\pi r$, then ink a TekBot wheel, measure it for themselves and use the equation to calculate revolutions and distance.

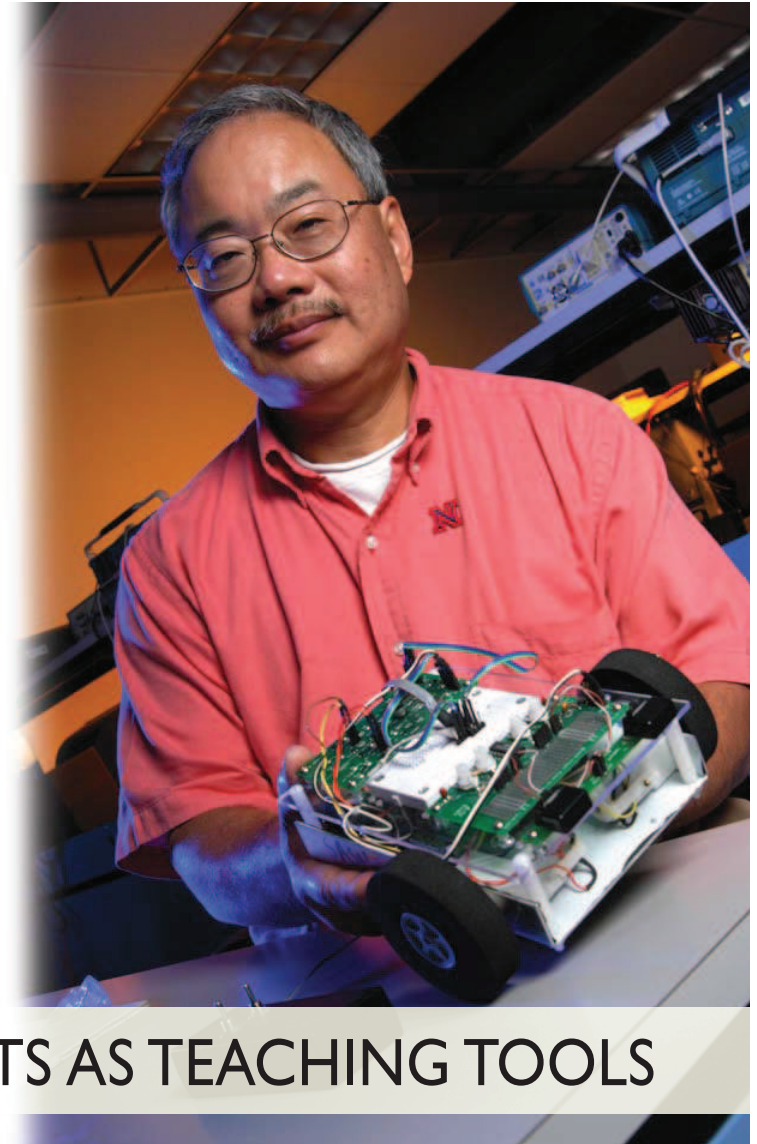

Bing Chen with a TekBot.

TURNING LOOSE TEKBOOTS AS TEACHING TOOLS

Students, Chen said, “don’t always see the payoff to what they’re studying.” He thinks that’s one reason fewer American students choose math and science careers. He designed SPIRIT to introduce young people to math and science at an early age and perhaps encourage more of them, particularly underrepresented women and minorities, to choose engineering careers.

“The teachers are, obviously, the front line,” Chen said. So in summer 2006, about 40 middle school teachers built their own TekBots and, with the help of UNL engineers, brainstormed lesson plans for their classrooms. SPIRIT aims to train 100 teachers in the next three years. The program will host a Web site and ongoing training so

teachers can share stories and new ideas. UNL engineering students will mentor middle school students throughout the school year.

Chen hopes the classroom is just the beginning for TekBots. He envisions robotics clubs and citywide TekBot competitions in which student-designed robots must complete mazes and other challenges.

“I see this as a mechanism for the 21st-century Soapbox Derby.” ■

SSW15. Teachers rev up robotics knowledge

By Julie Blum jblum@columbustelegram.com

Friday, June 26, 2009 - 09:20:49 am CDT

COLUMBUS - Small robotic cars will be making appearances in the classroom to help students learn about math, science and technology.

Several local and area teachers are taking part in a two-week Summer Robotics Institute at Central Community College-Columbus. The 21 teachers built the cars last week and are currently developing lesson activities they will be able to use with their students for the upcoming school year.

"This puts math and science concepts in a realistic context," said Neal Grandgenett.

He is a math professor at the Peter Kiewit Institute, one of the partners along with CCC-Columbus, Columbus Public Schools, the University of Nebraska-Lincoln and the University of Nebraska-Omaha for the workshop.



Jeff Korus, right, a math teacher at Humphrey St. Francis High School, speaks with University of Omaha Math Professor Neal Grandgenett about robotics during a two-week Summer Robotics Institute at Central Community College-Columbus. Telegram photo by Blaine McCartney

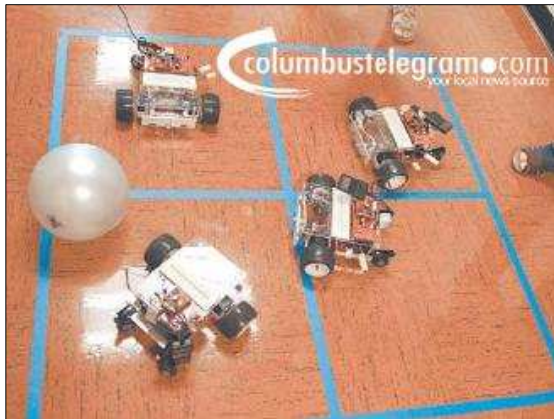

A game of four square is played by Nebraska high school teachers using the radio-controlled robot cars. Telegram photo by Blaine McCartney

A two-year Career Education Partnership Act grant is funding the workshop.

Teachers participating are at the middle school and high school levels teaching in the math, science and technology areas. Each teacher gets to take three robotic cars back to their schools when they complete the workshop.

Shantelle Suiter, a math teacher at Columbus Middle School, said she is looking forward to using the robot in her classroom. Her students, she said, are technologically savvy, so this will be right up their alley.

It will provide a unique way to help students get hands-on lessons in mathematics because every part

of the robot, from the circumference of wheels it rolls on to the engineering it takes to develop it, involves numbers and formulas.

"Technology is math. Without the math, you wouldn't have technology," she said.

St. Isidore Elementary School teacher Megan DeWispelare said she was involved in the workshop because she was looking for ways to incorporate more technology into her teaching. She teaches computers, and also math and science to sixth graders.

She plans on using the robots with her computer students. Even the youngest kindergarten students will be able to use them because the cars are controlled with a device that many of them are used to, a PlayStation 2 controller.

Dan Davidchik, Mechatronics Project Coordinator at CCC-Columbus, said the workshop is another way of growing the awareness of technology as a teaching tool. The Mechatronics Education Center at CCC-Columbus emphasizes technical careers. Several workshops open to middle school, high school and college teachers, and industry workers focusing on technology have been offered through the center.

####

<http://www.columbustelegram.com/articles/2009/06/27/news/local/doc4a44d11654144160425670.txt>



Dwayne Probyn
Executive Director

Published by The Nebraska Advanced Manufacturing Coalition (NAMC)

October, 2009

Dream It. Do It. Receives Grant

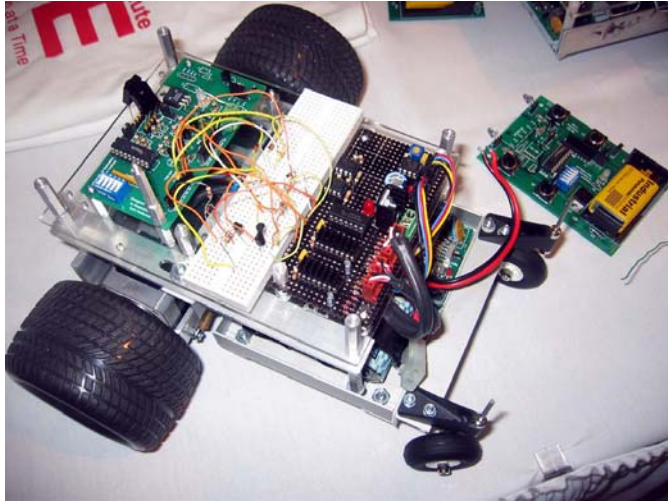

The Midlands Community Foundation places an emphasis on prevention and education. The mission of the foundation is to benefit the diverse needs of the Sarpy and Cass county communities.

Dream It. Do It. has been awarded a grant for \$22,400 from the Midland Community Foundation. This grant money will be used to purchase 72 CEENBot kits (see picture of completed CEENBot).

The following schools will receive 10 CEENBots each:

| | |
|--------------------------------|--------------------------|
| Papillion La-Vista High School | Papillion La-Vista South |
| Conestoga High School | Louisville High School |
| Elmwood Murdock High School | Plattsmouth High School |
| Weeping Water High School | 2 CEENBots for DIDI |

The CEENBot is an educational tool to use in STEM classes (Science, Technology, Engineering, Math) to introduce robotics to students. The CEENBot platform is developed by the Peter Kiewit Institute in Omaha. This platform is a flexible education tool allowing teachers to integrate the platform into their current instruction with ready-made education lessons that are mapped to national standards in STEM.

For more information on the CEENBot and to view the education tools, go to:

<http://www.ceen.unomaha.edu/TekBots/SPIRIT2/>

IMES

The Nebraska Department of Education sponsored an IMES (Industrial, Manufacturing and Engineering Systems) in-service throughout the state of Nebraska and asked Dream It. Do It. to present its program again this year.

IMES sessions were held in Scottsbluff, North Platte, Hastings, Lincoln, Norfolk, and Omaha.

This is a wonderful opportunity to get the Dream It. Do It. coalition's message out to teachers and the community in Nebraska.

EPSCOR

DIDI hosts a table at the EPSCOR (Experimental Program to Stimulate Competitive Research) 5th Annual Innovation Conference.



In picture-- Tyler Wortman, CDT Spokesperson; Dwayne Probyn, DIDI Executive Director; and Senator Scott Price

CCC Design Technology



More than 270 people visited one of the nation's best-equipped machine tool technology education programs on October 29th when Central Community College-Hastings sponsored an open house for its

Midwest Center for Plastics and Design.

A big draw for representatives of some 50 business and industries who attended the open house was **15 new CNC machine tools** recently added to the campus machine tool technology program.

The new equipment was provided through a \$2.1 million Community-Based Job Training grant from the US Dept. of Labor awarded to the college to develop a program in design technology and to establish the Midwest Center for Plastics and Design.

NAMC Scorecard

| 2009 Events We've Attended | Est. Attend. | Est. Contacts | Quality Contacts |
|-------------------------------|---------------|---------------|------------------|
| High School Career Fairs | 5,543 | 1,915 | 688 |
| Classroom presentations | 1,232 | 882 | 587 |
| College Career Fairs | 308 | 120 | 70 |
| Civic/Community Presentations | 963 | 870 | 770 |
| Mfg. Tours | 915 | 915 | 500 |
| Miscellaneous | 4,960 | 2,013 | 917 |
| Year-to-date 2009 | 13,921 | 6,715 | 3,532 |
| Totals from 2006-2008 Events | <u>38,455</u> | <u>16,018</u> | <u>9,490</u> |
| Campaign Totals | 52,358 | 22,715 | 13,004 |

NAMC Board of Directors

| | |
|--------------------------|---------------------------------------|
| Tony Raimondo, Chairman* | Behlen Mfg. Co. |
| Tom Whalen, Vice Chair* | Blue Cross/Blue Shield of Nebraska |
| Dennis Baack* | Nebraska Community College System |
| J.B. Milliken | University of Nebraska |
| Catherine Lang | Commissioner, Nebraska Dept. of Labor |
| Richard Baier* | Dept. of Economic Development |
| Roger Breed | Commissioner, NE Dept. of Education |
| Barry Kennedy | Neb. Chamber of Commerce & Industry |
| David Brown | Omaha Chamber of Commerce |
| Wendy Birdsall | Lincoln Chamber of Commerce |
| K.C. Belitz | Columbus Chamber of Commerce |
| Mike Baldino | NAMC Secretary |
| Dwayne Probyn | NAMC Executive Director |

*Denotes Executive Committee Members

NAMC AREA DIRECTORS

| | | |
|-----------------------|--|--------------|
| Executive Director | Dwayne Probyn | 402-344-6122 |
| | dbp628@aol.com | |
| Omaha | John Vyhlidal | 402-895-9000 |
| | johnv@tri-vtool.com | |
| Lincoln | Linda Lichtenberg | 402-434-9140 |
| | linda.lichtenberg@lincolnmachine.com | |
| Northeast Nebraska | Jeff Scherer | 402-568-2937 |
| | max@smeal.com | |
| Columbus | Bernie Hansen | 402-270-0604 |
| | drive45@megavision.com | |
| Hastings/Grand Island | Kelly Christensen | 402-461-2558 |
| | kchristensen@cccneb.edu | |
| Holdrege | Roger Allmand | 800-562-1373 |
| | rallmand@allmand.com | |
| Western Nebraska | Dan Koch | 308-762-2975 |
| | dankoch@perrinmfg.com | |
| Dawson County | John Bell | 308-784-3902 |
| | jbdad@cozadtel.net | |



Reasons To Celebrate!

SEPTEMBER 2009

LINCOLN: Lincoln Machine participated in a job shadowing program with UNL Mechanical Engineering students.

NATIONAL: Dwayne Probyn attends DIDI Executive meeting in San Antonio.

COLUMBUS: Columbus Regional Career Dream Team spotlighted at local football games during half-time.

HASTINGS: CCC Design Technology Open House (see article on front).

STATE: DIDI presents at Industrial, Manufacturing & Engineering Systems (IMES) in-service across the state of Nebraska.

STATE: Tony Raimondo Presents DIDI at Manufacturing Summit in Lincoln, NE.

LINCOLN: TMCO hosts open house with manufacturing tours to approximately 500 students.

LINCOLN: Tyler Theillen of Lincoln Machine presents to Lincoln Northeast career classes—approx. 100 students.

October Mentor of the Month

Sarah Hampton



Sarah Hampton (Hanson) with Valmont Industries has been selected as October's Mentor of the Month for her continued dedication to the

DIDI Career Dream Team program. Some of the activities Sarah has been involved in include the DIDI Omaha Education Extension Committee, helped to select the Career Dream Team Candidate for Valmont, and Hosted the Career Dream Team members during the Texas Tech game on October 17th. Thanks Sarah — keep up the good work!

Blog— <http://www.didicdt.com>

You Tube—<http://www.youtube.com> in the search box type DProbyn

Facebook—<http://www.facebook.com> search for DreamItDoIt Nebraska

Web Site: -

<http://www.dreamit-doit.com/Nebraska>



**SPiRiT Teacher Participant Questionnaire - Start of Project
A Survey of Teachers**

Date _____

IRB #: 2005-05-341 EX (UNL)
173-05-EX (UNO)

Purpose: This brief survey is designed to help us understand a few of your educational opinions and perceptions so that we can better plan the year's Educational Robotics Institute activities. Your responses will remain anonymous but we ask for an ID number that you create in order to compare your responses before and after the Institute, to help us evaluate whether our Institute has been beneficial to you, based upon your opinion.

Private and Voluntary Participation: All data collected in this survey will be kept in the strictest confidence. No individual names will be reported in any report and only group information will be described. Individuals have the full right to participate or not participate in the survey as desired.

Survey Coordinated by: This survey is being coordinated by the University of Nebraska at Omaha. For information related to this survey, please contact:

Elliott Ostler, Ed.D. (Facilitator)
107 Kayser Hall
University of Nebraska at Omaha
Omaha, Nebraska 68182-0163

Phone: (402) 554-3486
E-mail: elliottostler@mail.unomaha.edu

Mike Timms, Ph.D. (External Project Evaluator)
Measurement and Evaluation Consultant
2700 West Newell Ave.
Walnut Creek, CA 94595

Phone: (925) 998-8820
E-mail: mtimms@wested.org

Study Principal Investigator: For more information related to the study contact:

Neal Grandgenett, Ph.D. (Principal Investigator)
107 Kayser Hall
University of Nebraska at Omaha
Omaha, Nebraska 68182-0163

Phone: (402) 554-2690
E-mail: ngrandgenett@mail.unomaha.edu

Temporary and Coded Identification

Please provide a temporary and coded ID number in order to help us track future responses for the coming year as you implement what you learn at the Institute.

Please designate an ID number that you will be able to remember: _____
(*Note: Please do not use any portion of a Social Security Number*)

Background and Demographics

Please respond to the items below to help us summarize general background and demographics information for students responding to this survey. All information will be kept confidential. Thank you!

1. Gender

Male Female

2. Ethnicity

African American Asian Latino Native American Caucasian Other (please specify)

3. Academic Qualifications (Check and give details of all that apply)

| | | | |
|-------------------------------------|-----------------------------------|-------------------------------------|---|
| Bachelor's Degree (BA, BS, etc.) | Master's Degree (MA, MS, etc.) | Advanced Degree (PhD, EdD, etc.) | Other Academic Qualification (please specify) |
| <input type="checkbox"/> | <input type="checkbox"/> | <input type="checkbox"/> | <input type="checkbox"/> |
| Subject: _____ | Subject: _____ | Subject: _____ | Subject: _____ |

4. Do you have any particular qualifications or experiences related to engineering, electronics, or educational robotics that you want us to know about?

5. Teaching Experience

Total years of teaching: _____ years

Of those total years, how many years have you taught any of the following topics?

Science: ____ Math: ____ Engineering: ____ Electronics: ____ Robotics: ____

Recent Professional Development

6. Please list any professional development workshops you have taken in the last 3 years.

| Topic of the professional development | Duration |
|---------------------------------------|----------|
| | |

7. Please describe any other relevant professional activities in the last 3 years. (e.g., mentoring new teachers, grants received, awards, committee service, etc.)

| Topic of the professional activity | Duration |
|------------------------------------|----------|
| | |

Perceptions - Project Based Learning

8. Please rate your level of agreement with the following statements.

| | Do Not agree | Agree Somewhat | Agree | Strongly Agree |
|---|-----------------------|-----------------------|-----------------------|-----------------------|
| a. My students are not used to long-term projects | <input type="radio"/> | <input type="radio"/> | <input type="radio"/> | <input type="radio"/> |
| b. My teaching often includes group activities for students | <input type="radio"/> | <input type="radio"/> | <input type="radio"/> | <input type="radio"/> |
| c. I have very little experience with Project-Based Learning | <input type="radio"/> | <input type="radio"/> | <input type="radio"/> | <input type="radio"/> |
| d. I have strategies for assessing students' work in groups | <input type="radio"/> | <input type="radio"/> | <input type="radio"/> | <input type="radio"/> |
| e. Project-Based Learning takes more time than it is worth | <input type="radio"/> | <input type="radio"/> | <input type="radio"/> | <input type="radio"/> |
| f. I am comfortable designing project-based learning activities | <input type="radio"/> | <input type="radio"/> | <input type="radio"/> | <input type="radio"/> |
| g. Students learn better individually than in groups | <input type="radio"/> | <input type="radio"/> | <input type="radio"/> | <input type="radio"/> |
| h. I know how to pace student learning in long-term projects | <input type="radio"/> | <input type="radio"/> | <input type="radio"/> | <input type="radio"/> |
| i. Project-based learning is effective for teaching science, technology, engineering and mathematics topics | <input type="radio"/> | <input type="radio"/> | <input type="radio"/> | <input type="radio"/> |
| j. I am comfortable with observing students in small groups | <input type="radio"/> | <input type="radio"/> | <input type="radio"/> | <input type="radio"/> |

Perceptions – Science Technology, Engineering and Mathematics (STEM) Disciplines

9. Please rate your level of agreement with the following statements.

| | Do Not agree | Agree Somewhat | Agree | Strongly Agree |
|---|-----------------------|-----------------------|-----------------------|-----------------------|
| a. Learning about science, engineering, technology and math is important to a students' academic success | <input type="radio"/> | <input type="radio"/> | <input type="radio"/> | <input type="radio"/> |
| b. I intend to take more professional development with a STEM focus. | <input type="radio"/> | <input type="radio"/> | <input type="radio"/> | <input type="radio"/> |
| c. I would advise my students to take as many STEM courses as they can. | <input type="radio"/> | <input type="radio"/> | <input type="radio"/> | <input type="radio"/> |
| d. Learning STEM subjects is difficult for students. | <input type="radio"/> | <input type="radio"/> | <input type="radio"/> | <input type="radio"/> |
| e. I know as much as I need to know about teaching STEM subjects. | <input type="radio"/> | <input type="radio"/> | <input type="radio"/> | <input type="radio"/> |
| f. I believe that all students can succeed in STEM disciplines. | <input type="radio"/> | <input type="radio"/> | <input type="radio"/> | <input type="radio"/> |
| g. My students struggle with STEM subjects. | <input type="radio"/> | <input type="radio"/> | <input type="radio"/> | <input type="radio"/> |
| h. Girls are less likely to succeed in STEM subjects than boys. | <input type="radio"/> | <input type="radio"/> | <input type="radio"/> | <input type="radio"/> |
| i. Minority students are less likely to succeed in STEM subjects than White students. | <input type="radio"/> | <input type="radio"/> | <input type="radio"/> | <input type="radio"/> |
| j. Students with a solid grasp of STEM subjects are better prepared for future careers than those who do not have a solid grasp of such subjects. | <input type="radio"/> | <input type="radio"/> | <input type="radio"/> | <input type="radio"/> |
| k. I personally find STEM subjects interesting. | <input type="radio"/> | <input type="radio"/> | <input type="radio"/> | <input type="radio"/> |
| l. Educational robotics is a useful context for learning STEM concepts. | <input type="radio"/> | <input type="radio"/> | <input type="radio"/> | <input type="radio"/> |
| m. Educational robotics can be easily integrated into many STEM courses within a middle school context. | <input type="radio"/> | <input type="radio"/> | <input type="radio"/> | <input type="radio"/> |

10. Any other comments?

Evolving SPIRIT Experiences

11. To help us better understand how your experience level changes and evolves during this year of activities, please identify your “general experience” with each of the following topics at this time. Please check the most appropriate response.

A: Not at all - no experience at all
B: Low - a little experience
C: Medium - some moderate experience
D: High - very experienced

| | | | | | |
|-----------|-------------------------------|------------|-----|--------|------|
| a. | Engineering | Not at all | Low | Medium | High |
| b. | Electronics | Not at all | Low | Medium | High |
| c. | Robotics | Not at all | Low | Medium | High |
| d. | Programming | Not at all | Low | Medium | High |
| e. | Computers | Not at all | Low | Medium | High |
| f. | Cooperative Learning | Not at all | Low | Medium | High |
| g. | Problem Based Learning | Not at all | Low | Medium | High |

Evolving SPIRIT Expectations

12. We would also like to know what you most desire and expect to get out of the project at this time. Please answer the following two questions:

a. What do you personally hope to get out of the project?

b. What do you most hope to accomplish related to your students?

Thank-You!

Thank-you for completing this survey, and we look forward to working with you in the SPIRIT project this year!

Pilot and Field Testing of the National 4-H Educational Robotics Curriculum

Curriculum Pilot Testing

Teacher Facilitator Feedback Survey

Form Purpose: The following feedback form is to be used by facilitators in piloting the 4-H educational robotics lessons and activities in the classroom, and for making suggestions for improvement. All responses will be kept completely confidential, and only used in the lesson revision process.

Lesson Information:

Reviewer/Facilitator Name: _____

Robotics Lesson/Activity Piloted: _____

Location Where Piloting Took Place: _____

Project Evaluation Contact:

Dr. Neal Grandgenett, UNO

Phone: 402-554-2690

ngrandgenett@mail.unomaha.edu

Piloting Feedback

Lesson Feedback: Please give your perceptions on the different educational robotics lesson components.

| | Strongly Disagree | Disagree | Neutral | Agree | Strongly Agree |
|--|-------------------|----------|---------|-------|----------------|
| 1) The lesson/activity helped youth to learn about science or science concepts. | ↑ | ↑ | ↑ | ↑ | ↑ |
| 2) The lesson/activity helped youth to learn about technology or technology concepts. | ↑ | ↑ | ↑ | ↑ | ↑ |
| 3) The lesson/activity helped youth to learn about engineering or engineering concepts. | ↑ | ↑ | ↑ | ↑ | ↑ |
| 4) The lesson/activity helped youth to learn about mathematics or mathematics concepts. | ↑ | ↑ | ↑ | ↑ | ↑ |
| 5) The lesson/activity was interesting to youth. | ↑ | ↑ | ↑ | ↑ | ↑ |
| 6) The lesson/activity was engaging to youth. | ↑ | ↑ | ↑ | ↑ | ↑ |

7) For you personally as a teacher or facilitator, what were the positive aspects of the lesson?

8) For you personally as a teacher or facilitator, how could the overall lesson or activity be improved?

Important Final Task: Please make any instructional comments, suggested edits, or revision thoughts on an attached copy of the lesson or activity itself. Thanks! Your feedback is deeply appreciated!

Pilot and Field Testing of the SPIRIT Project Curriculum

Curriculum Pilot Testing Student Feedback Form

Form Purpose: Thank-you for trying out some of the robotics activities with us. We want to know what you learned, how you liked the robotics activities, and if you have any suggestions for their improvement. Your feedback will be kept confidential and will only used to make the activities better.

Lesson Information:

Reviewer/Facilitator Name: _____

Robotics Lesson/Activity Piloted: _____

Location Where Piloting Took Place: _____

Project Evaluation Contact:

Dr. Neal Grandgenett, UNO

Phone: 402-554-2690

ngrandgenett@mail.unomaha.edu

| |
|---|
| Robotics Activity Student Feedback |
|---|

Activity Feedback: Please give your perceptions on the different educational robotics lesson components.

| | Strongly Disagree | Disagree | Neutral | Agree | Strongly Agree |
|--|-------------------|----------|---------|-------|----------------|
| 1) The lesson/activity helped me to learn about science or science concepts. | ↑ | ↑ | ↑ | ↑ | ↑ |
| 2) The lesson/activity helped youth to me to learn about technology or technology concepts. | ↑ | ↑ | ↑ | ↑ | ↑ |
| 3) The lesson/activity helped me to learn about engineering or engineering concepts. | ↑ | ↑ | ↑ | ↑ | ↑ |
| 4) The lesson/activity helped me to learn about mathematics or mathematics concepts. | ↑ | ↑ | ↑ | ↑ | ↑ |
| 5) I found the lesson or activity to be interesting. | ↑ | ↑ | ↑ | ↑ | ↑ |
| 6) I would tell my friends that the activity was a good one. | ↑ | ↑ | ↑ | ↑ | ↑ |

7) For you personally, what was the best part of the lesson? Why?

8) For you personally, how could the overall lesson or activity be improved?

9) Anything else that you would like to tell us?

| |
|--|
| Thank-you! Your feedback to us is deeply appreciated! |
|--|



Sample Questions - 4-H Robotics and GPS/GIS and SPIRIT Content Quiz - Pre

Name: _____ **State** _____

Leader Name: _____

Age: _____ **Gender (circle one):** Male Female

Multiple Choice: For each of the following questions, circle the letter of the answer that best answers the question.

1. In order to follow a delayed sequence of set movements, without direct user control, a robot must be _____.
 - A. controlled by a remote.
 - B. computerized.
 - C. programmed.
 - D. trained.

2. A programming "loop" does which of the following?
 - A. Starts the program code
 - B. Stops the program code
 - C. Performs multiple functions
 - D. Repeats a section of program code

3. A computer program consists of _____ that tells the computer to do something.
 - A. sensors
 - B. code
 - C. lights
 - D. robots

4. Which of the following enables a robot to investigate and react to its environment?
 - A. Tires
 - B. Sensors
 - C. LCD panels
 - D. Mechanical arms

5. What is a computer program?
 - A. Computer generated text
 - B. The hardware that controls a computer
 - C. Instructions written in a language a computer understands
 - D. Language that is built into a robot

6. Which of the following is a wireless connection?
 - A. Bluetooth
 - B. RCX
 - C. USB
 - D. Serial port

7. When programming your robot, a switch block or if/else/then statement is used to _____.
 - A. ask a question.
 - B. stop the program.
 - C. speed up the program.
 - D. repeat the code.



8. Which of the following is an example of multi-tasking?
 - A. Having your robot move forward on a table
 - B. Having your robot turn to the left for 2 seconds
 - C. Having your robot measure a distance as it identifies an object to lift
 - D. Having your robot use its light sensor

9. The process of refining an instrument, like your robot, so that it is as accurate as possible by collecting information about how far your robot will travel in a given amount of time and using the information to estimate how long it will take the robot to go a given distance is called _____.
 - A. a ratio.
 - B. the Pythagorean Theorem.
 - C. a threshold value.
 - D. calibration.

Amie and Cody are engineers working to design a robot that will be able to plant trees in a fruit production orchard with apples, apricots, oranges and/or peaches. They need your help to apply the steps of the Engineering Design Process. Answer the questions below to provide your assistance.



Image of an apple orchard from Kelowna Land and Orchard Company Ltd. (KLO) in British Columbia, Canada. Image from <http://media-cdn.tripadvisor.com/media/photo-s/00/11/f9/0a/orchard-at-kelowna-land.jpg> used without permission.

10. Which of the following would not be part of the problem that Amie and Cody need to solve in order to begin designing their robot?
 - A. The robot must be able to travel in standing water.
 - B. The robot must be able to avoid obstacles such as large rocks and existing trees.
 - C. The robot must be able to go to a specific location, using GPS.
 - D. The robot must be able to dig a hole.



11. As a part of the design process, Amie and Cody visit an engineering library to look at existing patents. Which step in the Engineering Design Process are they doing?
 - A. Identify the problem
 - B. Research the problem
 - C. Select a solution
 - D. Construct a prototype

12. Amie and Cody are reviewing the possible solutions to select one to test by building a prototype. Which of the solutions below do you think is **most** important to the project?
 - A. The robot should operate quietly to lessen the disturbance to wildlife in the area.
 - B. The robot should be on tracks to cover diverse terrains.
 - C. The robot should have a camera so the operators can see what it is doing from anywhere with an Internet connection.
 - D. The robot should have a robotic arm that can do tasks such as dig the hole, place the tree and replace the soil.

13. Which of the following strategies would be important to evaluating Amie and Cody's solution?
 - A. Testing the prototype by planting trees in different orchard settings or environments
 - B. Asking other engineers on your team to review their design and prototype
 - C. Check the design with specialized computer software to find potential flaws
 - D. All of the above

Technology – Robotic Programming

Use the obstacle course shown to answer the robot programming questions below. The dashed line(s) shows the path of the robot. The solid line is a black electrical tape one inch wide

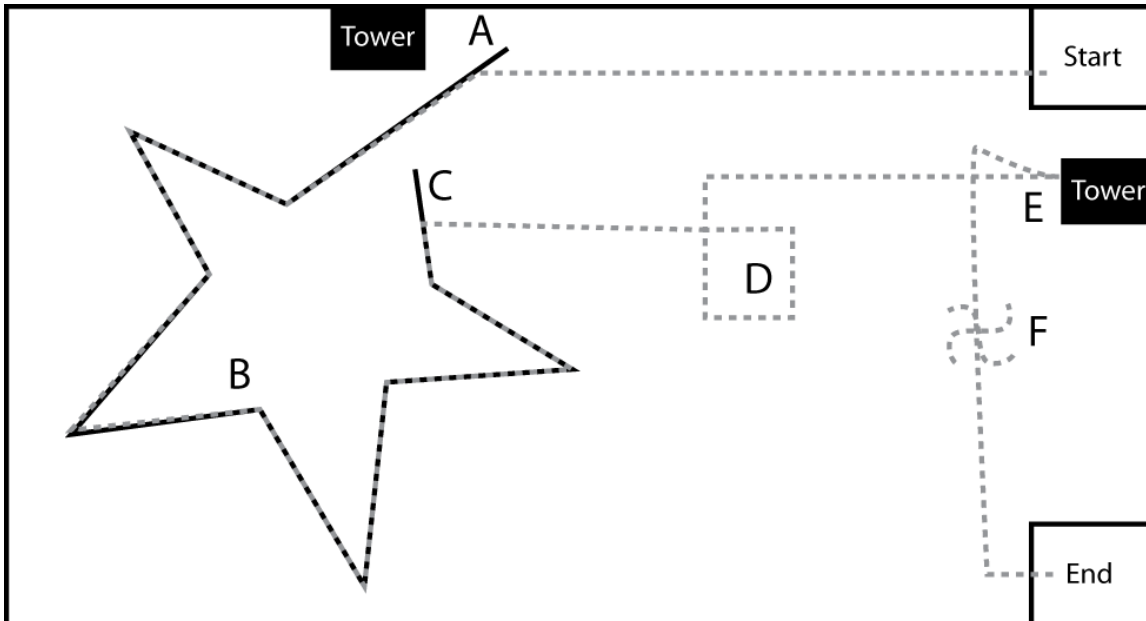

14. Which sensor is most likely used to navigate the robot between points A and C?
 - A. Light
 - B. Sound
 - C. Touch
 - D. Ultrasonic



15. Which of the marked points on the image above corresponds to the pseudocode shown here:
Loop 4 times – Forward one tire rotation, Turn ninety degrees right
- A. Point B
 - B. Point D
 - C. Point E
 - D. Point F
16. At point F, the robot spins counterclockwise for at least 1080 degrees. Which pseudocode line would cause the robot to turn 1080 degree?
- A. Forward, left motor 10 rotations
 - B. Forward, right motor 10 rotations
 - C. Forward turning to the left, left and right motors 10 rotations
 - D. Forward turning to the right, left and right motors 10 rotations
17. Which of the marked points in the image above corresponds to the pseudocode shown here:
Wait until touch, reverse two wheel (720 degrees) rotations
- A. B
 - B. D
 - C. E
 - D. F
18. Which of the sensors listed would most likely not be used to complete this challenge?
- A. Light
 - B. Sound
 - C. Touch
 - D. Rotation
19. Which pseudocode is the most reliable way to program the robot at point C (find the tower and then turn, using an ultrasonic sensor) in the image above?
- A. Forward 2.3 wheel rotations to the tower
 - B. Forward 828 degrees to the tower
 - C. Forward 1.6 seconds to the tower
 - D. Forward until 15 inches from the tower



Robotics Workplace Skills Youth Questionnaire (Pre)

| | |
|-----------------------|---------------------------------------|
| Name: _____ | Date: _____ |
| Club or School: _____ | Gender (circle one) Male Female |

We want to know how well the robotics activities help you to develop certain skills. **Please respond to the items below in terms of how you can contribute to your team in undertaking the robotics activities or in preparing the team project and documentation for the Robotics Showcase.** It should take you about 5 to 10 minutes to fill out this survey. The results will help us to learn how you are benefiting from this educational program and if we need to make any changes.

| Statement | Strongly Agree | Agree | Neither Agree nor Disagree | Disagree | Strongly Disagree |
|---|----------------|-------|----------------------------|----------|-------------------|
| 1. I am able to brainstorm (come up with) a number of possible strategies to accomplish the robotics challenge. | 5 | 4 | 3 | 2 | 1 |
| 2. I am able to determine how mistakes in programming the robot can lead to a problem with other parts of the design and build process. | 5 | 4 | 3 | 2 | 1 |
| 3. I am able to evaluate solutions suggested by my teammates and predict which of them might work. | 5 | 4 | 3 | 2 | 1 |
| 4. I am able to identify and ask questions that will lead to a better team solution. | 5 | 4 | 3 | 2 | 1 |
| 5. I am able to explain my ideas and findings to my team. | 5 | 4 | 3 | 2 | 1 |
| 6. I am comfortable presenting results produced by my team to the judges. | 5 | 4 | 3 | 2 | 1 |
| 7. I am able to interact professionally with the contest officials. | 5 | 4 | 3 | 2 | 1 |
| 8. I am able to come up with creative ideas to help solve problems. | 5 | 4 | 3 | 2 | 1 |
| 9. I am able to evaluate alternative ideas and solutions in order to improve the robot's computer program. | 5 | 4 | 3 | 2 | 1 |
| 10. I am patient with my teammates. | 5 | 4 | 3 | 2 | 1 |
| 11. In the competition I realize that it is often necessary to work with different people. | 5 | 4 | 3 | 2 | 1 |
| 12. I am open to ideas from other team members. | 5 | 4 | 3 | 2 | 1 |
| 13. I am able to help my team to accomplish the task within the allocated time frame. | 5 | 4 | 3 | 2 | 1 |
| 14. Compromising with other team members is sometimes necessary to accomplish our goals. | 5 | 4 | 3 | 2 | 1 |
| 15. I am able to share responsibility with my teammates. | 5 | 4 | 3 | 2 | 1 |

Nebraska 4-H Robotics and GPS/GIS and SPIRIT Project

| | | | | | |
|--|---|---|---|---|---|
| 16. Whatever my role in the competition I am able to follow through on the tasks needed to help to complete our team activity. | 5 | 4 | 3 | 2 | 1 |
| 17. I am able to work with the team to help to prioritize, plan and manage the work to achieve the desired results. | 5 | 4 | 3 | 2 | 1 |
| 18. I am an active participant in our team. | 5 | 4 | 3 | 2 | 1 |
| 19. I am able to evaluate alternative ideas and solutions in order to improve the team project. | 5 | 4 | 3 | 2 | 1 |
| 20. I am able to demonstrate leadership on selected tasks to help support my team. | 5 | 4 | 3 | 2 | 1 |
| 21. Other team members are able to count on me to get something done. | 5 | 4 | 3 | 2 | 1 |



4-H Robotics and GPS/GIS and SPIRIT Interest Questionnaire - Pre

Name: _____ State _____

Leader Name: _____

Age: _____ Gender (circle one): Male Female

Ethnicity (circle one):

African American American Indian Asian or Pacific Islander Hispanic White (non Hispanic) Other _____

We are interested in learning about your attitudes towards science, technology, engineering, and mathematics. We particularly want to get your reaction to learning about robotics, which involves the building and programming of small robots. We also are interested in your attitudes about GPS (Global Positioning Systems) and GIS (Geographical Imaging Systems). GPS helps us record and use satellite data to understand geographical location and mapping concepts. GIS is a computer tool you can use to develop, analyze, and display geographic maps.

Read the statements below and circle your opinion.

| Statement | Strongly Agree | Agree | Neither Agree nor Disagree | Disagree | Strongly Disagree |
|---|----------------|-------|----------------------------|----------|-------------------|
| 1. It is important for me to learn how to conduct a scientific investigation. | 5 | 4 | 3 | 2 | 1 |
| 2. It is important for me to learn about robotics. | 5 | 4 | 3 | 2 | 1 |
| 3. It is important for me to learn how to use appropriate tools and techniques to gather, analyze and interpret data. | 5 | 4 | 3 | 2 | 1 |
| 4. It is important for me to learn about GIS. | 5 | 4 | 3 | 2 | 1 |
| 5. It is important for me to learn how to use mathematical formulas to help solve practical problems. | 5 | 4 | 3 | 2 | 1 |
| 6. It is important for me to learn how to make accurate measurements to help solve mathematical problems. | 5 | 4 | 3 | 2 | 1 |
| 7. It is important for me to be able to record measurements and calculations into tables and charts. | 5 | 4 | 3 | 2 | 1 |
| 8. It is important for me to learn how to collect and interpret data to verify a prediction or hypothesis. | 5 | 4 | 3 | 2 | 1 |
| 9. It is important for me to understand basic engineering concepts (e.g. design tradeoffs, speed, torque) related to building and moving a robot. | 5 | 4 | 3 | 2 | 1 |
| 10. It is important for me to learn how to program a robot to carry out commands. | 5 | 4 | 3 | 2 | 1 |
| 11. It is important for me to learn about GPS. | 5 | 4 | 3 | 2 | 1 |
| 12. I like learning new technologies such as robotics. | 5 | 4 | 3 | 2 | 1 |

Nebraska 4-H Robotics and GPS/GIS and SPIRIT Project

| Statement | Strongly Agree | Agree | Neither Agree nor Disagree | Disagree | Strongly Disagree |
|---|----------------|-------|----------------------------|----------|-------------------|
| 13. I like using the scientific method to solve problems. | 5 | 4 | 3 | 2 | 1 |
| 14. I like using mathematical formulas and calculations to solve problems. | 5 | 4 | 3 | 2 | 1 |
| 15. I like learning new technologies like GPS. | 5 | 4 | 3 | 2 | 1 |
| 16. I use a step by step process to solve problems. | 5 | 4 | 3 | 2 | 1 |
| 17. I make a plan before I start to solve a problem. | 5 | 4 | 3 | 2 | 1 |
| 18. I am confident that I can program a robot to move forward two wheel rotations (i.e. 720 degrees) and then stop. | 5 | 4 | 3 | 2 | 1 |
| 19. I try new methods to solve a problem when one does not work. | 5 | 4 | 3 | 2 | 1 |
| 20. I carefully analyze a problem before I begin to develop a solution. | 5 | 4 | 3 | 2 | 1 |
| 21. In order to solve a complex problem, I break it down into smaller steps. | 5 | 4 | 3 | 2 | 1 |
| 22. I am certain that I can build a robot by following design instructions. | 5 | 4 | 3 | 2 | 1 |
| 23. I am certain that I can fix the software program for a robot that does not behave as expected. | 5 | 4 | 3 | 2 | 1 |
| 24. I am certain that I can log locations of a series of waypoints within a GPS unit. | 5 | 4 | 3 | 2 | 1 |
| 25. I am confident that I can program a robot to follow a black line using a light sensor. | 5 | 4 | 3 | 2 | 1 |
| 26. I am confident that I can read and understand maps. | 5 | 4 | 3 | 2 | 1 |
| 27. I am confident that I can make a digital map. | 5 | 4 | 3 | 2 | 1 |
| 28. I am confident that I can use GPS technologies to get to places that I have never been before. | 5 | 4 | 3 | 2 | 1 |
| 29. I like listening to others when trying to decide how to approach a task or problem. | 5 | 4 | 3 | 2 | 1 |
| 30. I like being part of a team that is trying to solve a problem. | 5 | 4 | 3 | 2 | 1 |
| 31. When working in teams, I ask my teammates for help when I run into a problem or don't understand something. | 5 | 4 | 3 | 2 | 1 |
| 32. I like to work with others to complete projects. | 5 | 4 | 3 | 2 | 1 |
| 33. I like learning new technologies such as GIS. | 5 | 4 | 3 | 2 | 1 |

Nebraska 4-H Robotics and GPS/GIS and SPIRIT Project

How interested are you in each of the jobs below for possible future careers?

| Job | Very Interested | Somewhat Interested | Neither Interested nor Uninterested | Somewhat Uninterested | Very Uninterested |
|--------------------------------------|------------------------|----------------------------|--|------------------------------|--------------------------|
| 1. Scientist | 5 | 4 | 3 | 2 | 1 |
| 2. Engineer | 5 | 4 | 3 | 2 | 1 |
| 3. Mathematician | 5 | 4 | 3 | 2 | 1 |
| 4. Computer or Technology Specialist | 5 | 4 | 3 | 2 | 1 |
| 5. Job involving GPS/GIS | 5 | 4 | 3 | 2 | 1 |



4-H Robotics and GPS/GIS and SPIRIT Longitudinal Survey

Today's Date: _____

First Name: _____ Last Name: _____

School: _____ Age: _____

Grade in School: ___ 7 ___ 8 ___ 9 ___ 10 ___ 11 ___ 12 ___ not currently in school

Gender: ___ F ___ M

Race/Ethnicity: Check all that apply

- ___ Asian/Pacific Islander
- ___ Native American
- ___ Hispanic/Latina/o
- ___ Black/African-American (non- Latina/o)
- ___ White (non-Latina/o)
- ___ Multi-Racial
- ___ Other: _____

Years you attended the Robotics and GPS/GIS summer camp: Check all that apply

___ 2007 ___ 2008 ___ 2009 ___ 2010 ___ 2011

Did you attend a year two camp? ___ No ___ Yes **→** If yes, what year? _____

CONTACT INFORMATION FOR FOLLOW-UP SURVEY

4-H/SPIRIT is interested in the courses you take in school after attending a course, camp or club program. The following information will help us to find you in the coming years, for the follow-up surveys. Thank you for giving us the names of people who will be able to help locate you in case you have moved.

Your email address: _____

Your cell phone number: _____

Your current mailing address: _____

School that you plan to attend next year (2009-2010):

- ___ Same school
- ___ New school (Name of new school: _____)
- ___ Don't know

Name, phone number and address of a relative (grandparent, aunt, uncle) or friend who will know how to contact you if you are to move:



1) Did the robotics activities influence your decision to take more science, technology, engineering, or mathematics classes? ___ Yes ___ No

2) Please list all the classes that you are **currently** taking:

| Course | Name of the course |
|-------------|--------------------|
| Mathematics | |
| Science | |
| Technology | |
| Engineering | |

3) Here is a list of science, math, technology and engineering courses offered in many high schools. Mark the courses you think you'll take some time during high school. *Check one answer for each course.*

| Course | Very Likely | Likely | Unlikely | I don't know | Already taken |
|-----------------------|-------------|--------|----------|--------------|---------------|
| Pre-Algebra | | | | | |
| Algebra I | | | | | |
| Geometry | | | | | |
| Algebra II | | | | | |
| Pre-Calculus | | | | | |
| Calculus | | | | | |
| Chemistry | | | | | |
| Physics | | | | | |
| Biology | | | | | |
| Computer | | | | | |
| Computer Science | | | | | |
| Earth Science | | | | | |
| Anatomy | | | | | |
| Environmental Science | | | | | |



| Course | Very Likely | Likely | Unlikely | I don't know | Already taken |
|--------------|-------------|--------|----------|--------------|---------------|
| Other: _____ | | | | | |
| Other: _____ | | | | | |
| Other: _____ | | | | | |
| Other: _____ | | | | | |

4) What level of education do you think you will complete? *Check one.*

- High School
- GED (General Education Diploma)
- Community College (two-year college program)
- College (four or five year college program)
- Graduate School - Master's Degree
- Graduate School - Doctoral Degree (Ph.D.)
- Medical, Dental, or Veterinary School
- Law School
- Other (*Please describe* _____)

5) What do you think will be your major in college?

6) List one job that you think you'd like to have as an adult.

7) How interested are you in each of the jobs below for possible future careers?

| Job | Very Interested | Somewhat Interested | Neither Interested nor Uninterested | Somewhat Uninterested | Very Uninterested |
|--------------------------|-----------------|---------------------|-------------------------------------|-----------------------|-------------------|
| 1. Scientist | 5 | 4 | 3 | 2 | 1 |
| 2. Engineer | 5 | 4 | 3 | 2 | 1 |
| 3. Mathematician | 5 | 4 | 3 | 2 | 1 |
| 4. Computer Specialist | 5 | 4 | 3 | 2 | 1 |
| 5. Job involving GPS/GIS | 5 | 4 | 3 | 2 | 1 |

Thank you for your participation!



▶ Parents ▶ Educators ▶ Career Counselors ▶ Employers

▶ KUDER.com Home

Sign Up or Log In:

▶ New Users

▶ Returning Users

▶ Administrators

Kuder Career Search with Person Match (Interest Inventory)

The *Kuder Career Search with Person Match* helps you discover your career interests, explore occupations beyond job titles, and effectively apply your personal interests to your career plans.

The Internet-based assessment is completed in approximately 20 minutes and provides immediate online scoring and reporting. You will receive an accurate report of your career interests which provides guidance for interpreting and using your results.

The report also includes the unique Person Match feature which compares your assessment results to a database of nearly 2,000 individuals working in today's occupations. Access career sketches for the 14 individuals—7 in each of your top two Kuder career clusters—whose interests most closely match your own. Learn about how these individuals came to work in this occupation and why they like what they do.

The online Kuder Career Search with Person Match report includes:

- *Kuder Career Clusters* ranked by how closely they match your interests. Clicking on a cluster name provides a description of the cluster and avenues for further exploration.
- 14 Person Match career sketches—7 each in your top two career clusters—for individuals in the career database whose interests most closely match your own. (In states that use the federal career clusters classification system, the report provides the top 3 Person Match sketches for each of your top 5 career clusters.)
- Links to explore occupational listings by education level within each of the clusters. Each occupation is crosswalked with and linked directly to additional information from the *Occupational Outlook Handbook*, O*Net™, and related military occupations to allow further exploration.
- Suggested steps for continuing career exploration and links to help you explore options for continuing your education.



[Return to your portfolio](#)
 Provided by: National Career Assessment Services, Inc.

Congratulations **Demetri F.**! You join more than 100 million people who have taken a Kuder® Interest Assessment. By reviewing your results and following the steps within the report you will learn how to begin your career exploration process. As you move through the report be sure to read all the information and answer the questions. We suggest that you review this report with family, friends, or a career counselor.

Step I. Review Your Kuder® Career Clusters Ranking

Occupations or jobs can be grouped into one of six areas. We call these areas career clusters. Your interests have been scientifically compared to a large group of occupational profiles and the results are presented below in rank order from best to least fit. Demetri, focus your attention on your top two clusters. Click on them to read their descriptions. As you read each description think about how similar the job activities are to what you might enjoy doing. But remember, life experiences influence your interests and career choices, and they may change over time. Adults today report having seven or more jobs in a life time, but usually the jobs remain in one or two clusters. This is why identifying your top two clusters is so important. Remember there are many different types of jobs in each of the clusters. In a moment you will be able to read about the jobs some people have who happen to have very similar interests to yours.

To help you keep track of your top clusters, click on the ★ to place them in your Kuder® Electronic Career Portfolio under "My Favorites".

| Cluster Name | Low (1-24) | Medium (25-74) | High (75-99) | |
|--------------------------|------------|----------------|--------------|---|
| Outdoor/Mechanical | 79 | | | ★ |
| Arts/Communication | 68 | | | ★ |
| Social/Personal Services | 67 | | | ★ |
| Science/Technical | 50 | | | ★ |
| Business Operations | 29 | | | ★ |
| Sales/Management | 1 | | | ★ |

Step II. Meet People With Interests Like Yours

When it comes to choosing careers, people tend to only think in terms of job titles, not the individuals behind them. In fact, most career assessments match you to job titles or occupations only. But, you are not a job title or occupation. We know that people who have similar interests find happiness and success in a wide range of careers. That's why we developed Person Match. Person Match compares your results with nearly 2000 people in satisfying careers. They represent over 90% of the occupations available in the United States today. They come from all walks of life and all regions of the United States. Your Person Match results are presented below. These are people who have interests most like yours. They all have found satisfying careers, and you can learn about them by reading their job sketches. Click on the person you would like to meet. Why? Because you might discover someone with interests like yours in a career you never thought of, or you might find someone doing exactly what you want to do. Either way it is a great way to explore. Even though their occupations may differ, they all have interests very much like you!

Outdoor/Mechanical

- Person Match 1
- Person Match 2
- Person Match 3
- Person Match 4
- Person Match 5
- Person Match 6
- Person Match 7

Arts/Communication

- Person Match 8
- Person Match 9
- Person Match 10
- Person Match 11
- Person Match 12
- Person Match 13
- Person Match 14

Step III. Explore Careers By Education Level

Demetri, now you know what your top two clusters are, and you have been able to read about the occupations of 14 people with interests similar to yours. Click [HERE](#) to be directed to an area where you can review information about each cluster. Click on a cluster name and then explore occupations within the cluster. Each cluster group presents a variety of occupations separated by the three levels of education or training normally required for a particular occupation. By clicking on a job title you will be directed to an area that provides important information you need regarding each occupation such as working conditions, education requirements, job outlook, earnings, related occupations and more. As you review this information save a list of your top ten occupations to explore in your Kuder® Electronic Career Portfolio under "My Favorite Occupations" by clicking on the ★ under the occupation title.

Step IV. Continuing Your Career Exploration

Step IV. Continuing Your Career Exploration

You may have chosen a career goal already, but it is always smart to gather more information. Discuss your results with your family and counselor. Consider doing a job shadow or internship. You can interview people who are working in areas that interest you, and visit the library or use the internet to do additional research. If you are thinking about going to college, determine whether you would benefit most by attending a technical school, community college or if you need a four year or more degree. Look at the technical education opportunities in your state or if you are considering college, explore **College Majors** to review college programs and corresponding careers within each area, or go to **College Search** to find colleges that offer programs you want. Remember to keep your Portfolio current, and record all of your exploration activities.

Demetri, today you discovered your prime interests and how to apply your personal results to your career search. But there is more that you need to know!

1. What are your best skills? (How can you use them?)
2. What work values are most important to you?

You should complete the Kuder Skills Assessment and Super's Work Values Inventory-revised, if you haven't already. By combining your interests, skills, and work values results, you establish a solid foundation to build your career goals and plans.

Demetri, thank you for completing the Kuder Career Search with Person Match. If you have any questions please contact us at 800-314-8972 (M-F 8:00AM to 5:00PM Central), e-mail us at ncasi@ncasi.com, or write us at National Career Assessment Services, Inc., 210 N 10th St, PO Box 277, Adel IA 50003.

The more you can learn about yourself and the world of work, the more likely you'll be able to identify careers that will bring you satisfaction and success!

[Back to top](#)

Copyright 2004 © National Career Assessment Services, Inc., tel: 800-314-8972. All rights reserved.
KUDER is a registered trademark of National Career Assessment Services, Inc.

For more information about development, administration, and interpretation of the interest assessment, please see the [Technical Manual](#)

The Kuder Interests and Skills Composite Report

Once you have completed both the *Kuder Career Search with Person Match* interest inventory and the *Kuder Skills Assessment*, an additional report, the *Kuder Interests and Skills Composite Report*, is automatically generated. The results of both assessments are juxtaposed to provide you with an easy-to-understand comparison of your interests and skills based on the career clusters. You can readily see areas where there are consistencies or inconsistencies in the relationship of your interests and skills. The interactive report provides information and suggestions about the relationships and how to proceed with your education and career exploration and planning.

KUDER Interests and Skills Composite Report

Return to your portfolio
Provided by: National Career Assessment Services, Inc.

Congratulations Demetri F.! You have completed both the Kuder® Career Search with Person Match and the Kuder® Skills Assessment. This report presents the results from the two, and makes suggestions for your career exploration and planning.

Step I. Review Your Interest/Skill Profile

Your interests and skills scores are shown below in a form that allows you to compare how your skills are related to your interests in each of the six career clusters. Click on the first cluster name to review the definition. Notice how your skills compare to your interests within this cluster. Read the statements carefully. Repeat this procedure for each of the clusters.

To help you keep track of your top clusters, click on the ★ to place them in your Kuder® Electronic Career Portfolio under "My Favorites".

| Cluster Name | Low (1-24) | Medium (25-74) | High (75-99) | |
|--|------------|----------------|--------------|---|
| Outdoor/Mechanical Interest Skill | 78 | 95 | 95 | ★ |
| This is a high-potential cluster for you. Find out more about the occupations in this cluster. They could promise success and satisfaction. | | | | |
| Arts/Communication Interest Skill | 68 | 90 | 90 | ★ |
| People sometimes downplay their interest in jobs that are easy for them. Have you looked carefully at the rewards of occupations in this cluster? Find out what people working in this area like about their jobs. | | | | |
| Social/Personal Services Interest Skill | 0 | 67 | 67 | ★ |
| People sometimes downplay their interest in jobs that are easy for them. Have you looked carefully at the rewards of occupations in this cluster? Find out what people working in this area like about their jobs. | | | | |
| Science/Technical Interest Skill | 50 | 90 | 90 | ★ |
| People sometimes downplay their interest in jobs that are easy for them. Have you looked carefully at the rewards of occupations in this cluster? Find out what people working in this area like about their jobs. | | | | |
| Business Operations Interest Skill | 29 | 83 | 83 | ★ |
| People sometimes downplay their interest in jobs that are easy for them. Have you looked carefully at the rewards of occupations in this cluster? Find out what people working in this area like about their jobs. | | | | |
| Sales/Management Interest Skill | 1 | 76 | 76 | ★ |
| You have medium or high skills in this cluster, but your interest appears low. Keep possibilities in this cluster "in reserve," and perhaps review how your work values affect your choices. | | | | |

Step II. How to Use Your Results

Having a high interest in a given cluster is an excellent way to begin to filter through all the career possibilities that exist. If you also have high skills in that same cluster, your career exploration becomes a little easier. If you have a moderate interest and a high to moderate skill ranking in a cluster, this is also an area to explore. Here is a plan to follow that will help you gather information.

Select seven possible careers from your top-ranked clusters. You may have already placed several in your portfolio or you can review occupational options by clicking [HERE](#) or select from your Person Matches. Now begin to gather information about them. You should learn at least the following about each occupation:

1. Job Description
2. Required Training
3. Employment Prospects
4. Where Jobs Are Located
5. Income Possibilities

Your school or local library will provide many other good sources of occupational information, both online and off the shelf. As you look at the different jobs within the clusters, think "Can I see myself in this picture? Is it an occupation that I would like to work in?"

Step III. Curriculum Planning

Next, ask yourself if you are willing to acquire the skills that the jobs require. Find out whether the required training is on-the-job, at a community college or technical school, or whether you need a four-year or more degree. See if you can discover what the key courses are, like calculus for engineers, or grammar and punctuation for journalists. Remember, the greater the skill level you acquire, the more rewarding your occupation will be in income and potential satisfaction. The more you find out about a career you are considering, the more confident you will be as you prepare for it.

The best way to learn about the requirements and rewards of any occupation is to get some direct, personal experience with it. Talk to someone who is actually in the career. Find out what they do in an average day or week; what is good and what is hard about it; what they had to do to get started; what they plan to do next. Try for a part-time or temporary job as an assistant or an intern, or at least do a day of job shadowing. This way you can learn what a career is really about, without it costing you a lot in time and effort. If you find that a career isn't so appealing after personal experience with it, don't give up hope. There are lots of job opportunities in each cluster that may fulfill your hopes and wishes. Be sure to record your experience in your Kuder Electronic Career Portfolio.

Step IV. What Else To Consider

Today you have discovered how your interests and skills relate to the Kuder® Career Clusters. There are many occupations in each, and you will need a thorough review on a smaller number for which you can make plans. If you have completed Super's Work Values Inventory-revised, use the results to consider your preferences for the characteristics of occupations and jobs. This is another tool you can use to fine-tune your career exploration. If you haven't completed the inventory, you should consider doing so. It is also a good idea to discuss your results with your family, friends, or a counselor.

October 15, 2009

Neal Grandgenett
107 Kayser Hall
UNO - VIA COURIER

IRB#: 443-09-EX

TITLE OF PROTOCOL: Evaluating the Silicon Prairie Initiative for Robotics in Information Technology (SPIRIT 2.0): Phase 2 Lesson Refinement

Dear Dr. Grandgenett:

The Office of Regulatory Affairs (ORA) has reviewed your application for Exempt Educational, Behavioral, and Social Science Research on the above-titled research project. According to the information provided, this project is exempt under 45 CFR 46:101b, category 1. You are therefore authorized to begin the research.

It is understood this project will be conducted in full accordance with all applicable HRPP Policies. It is also understood that the ORA will be immediately notified of any proposed changes that may affect the exempt status of your research project.

Please be advised that this research has a maximum **approval period of 5 years** from the original date of approval and release. If this study continues beyond the five year approval period, the project must be resubmitted in order to maintain an active approval status.

Sincerely,



Ernest D. Prentice, Ph.D.
Executive Chair, IRB

Sample Standardized Question Set

M018: Central Tendency

Answers: 1. C, 2. D, 3. D

1. The table below shows the average depth of each of the five deepest oceans and seas in the world.

Depths of World's Deepest Oceans and Seas

| Name | Depth (in feet) |
|----------------|-----------------|
| Atlantic Ocean | 12,880 |
| Caribbean Sea | 8,685 |
| Indian Ocean | 13,002 |
| Pacific Ocean | 13,215 |
| Sea of Japan | 5,468 |

What is the median depth of these five oceans and seas?

- A. 13,215 feet
- B. 13,002 feet
- C. 12,880 feet
- D. 10,650 feet

2. Sina's goal is to exercise a mean of 45 minutes per day for one week. For the first 6 days of the week, she exercised 35, 40, 37, 42, 45, and 50 minutes. What is the number of minutes Sina must exercise on the 7th day of the week to reach her goal exactly?

- A. 21 minutes
- B. 42 minutes
- C. 49 minutes
- D. 66 minutes

3. Jiro bowled 7 games in a tournament. The list below shows his scores for those 7 games.

149, 160, 180, 155, 160, 137, 158

What is the mode of Jiro's scores?

- A. 155
- B. 157
- C. 158
- D. 160

Source: MCAS: 2006, Mathematics - Grade 7
<http://www.doe.mass.edu/mcas/testitems.html>

SPIRIT Field Test “Big Ideas” Content Questions

Name: _____ Date _____

Age: _____ School: _____

PURPOSE: We are going to ask you a few questions about science, technology, engineering, and mathematics. Please answer as completely as possible, and draw diagrams or pictures if you would like to do so to give more information. We will ask you these questions before and after the robotics activities. Thanks!

PERCEPTIONS: Please show how much you agree or disagree with the following statements. Mark the box to the right that best indicates how much you agree or disagree with the statement.

| | Strongly Disagree | Disagree | Neutral | Agree | Strongly Agree |
|--|--------------------------|--------------------------|--------------------------|--------------------------|--------------------------|
| 1) I am good at doing science activities. | <input type="checkbox"/> | <input type="checkbox"/> | <input type="checkbox"/> | <input type="checkbox"/> | <input type="checkbox"/> |
| 2) I am good at using technology, such as robots. | <input type="checkbox"/> | <input type="checkbox"/> | <input type="checkbox"/> | <input type="checkbox"/> | <input type="checkbox"/> |
| 3) I am good at engineering, like building things. | <input type="checkbox"/> | <input type="checkbox"/> | <input type="checkbox"/> | <input type="checkbox"/> | <input type="checkbox"/> |
| 4) I am good at doing mathematics activities | <input type="checkbox"/> | <input type="checkbox"/> | <input type="checkbox"/> | <input type="checkbox"/> | <input type="checkbox"/> |
| 5) I enjoy doing science activities. | <input type="checkbox"/> | <input type="checkbox"/> | <input type="checkbox"/> | <input type="checkbox"/> | <input type="checkbox"/> |
| 6) I enjoy using technology, like robotics | <input type="checkbox"/> | <input type="checkbox"/> | <input type="checkbox"/> | <input type="checkbox"/> | <input type="checkbox"/> |
| 7) I enjoy engineering, such as building things | <input type="checkbox"/> | <input type="checkbox"/> | <input type="checkbox"/> | <input type="checkbox"/> | <input type="checkbox"/> |
| 8) I enjoy doing mathematics activities | <input type="checkbox"/> | <input type="checkbox"/> | <input type="checkbox"/> | <input type="checkbox"/> | <input type="checkbox"/> |

Content Questions: Please answer the following. You can draw pictures or diagrams.

9) **What is a robot?** Score: _____
Please explain your answer in writing, and use pictures or diagrams if desired.

10) **What is a variable?**

Score: _____

Please explain your answer in writing, and use pictures or diagrams if desired.

11) **What is the engineering design process?**

Score: _____

Please explain your answer in writing, and use pictures or diagrams if desired.

12) **What is a computer program?**

Score: _____

Please explain your answer in writing, and use pictures or diagrams if desired.

13) **What is science?**

Score: _____

Please explain your answer in writing, and use pictures or diagrams if desired.

14) **What is mathematics?**

Score: _____

Please explain your answer in writing, and use pictures or diagrams if desired.

15) **How are robots used in real life?**

Score: _____

Please explain your answer in writing, and use pictures or diagrams if desired.